

BLITZDUCTOR BXTU

BXT BAS • 920 300

BXTU ML4 BD 0-180 • 920 349

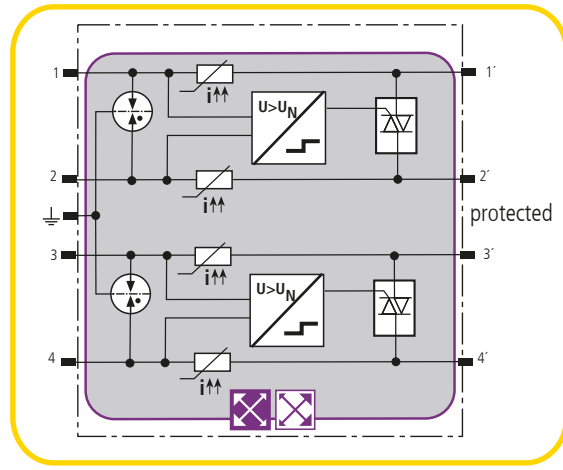
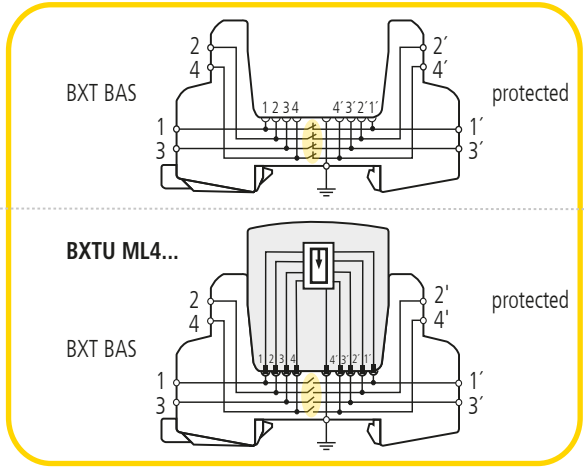

BXT BAS • 920 300

BXTU ML2 BD S 0-180 • 920 249

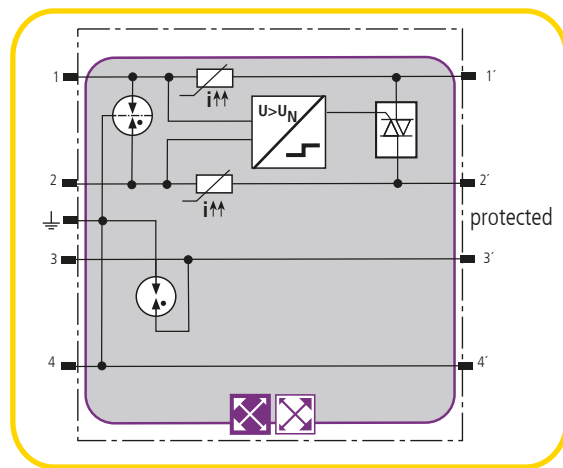
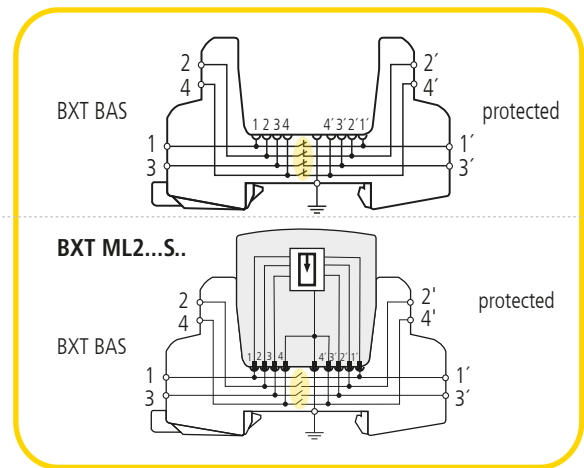
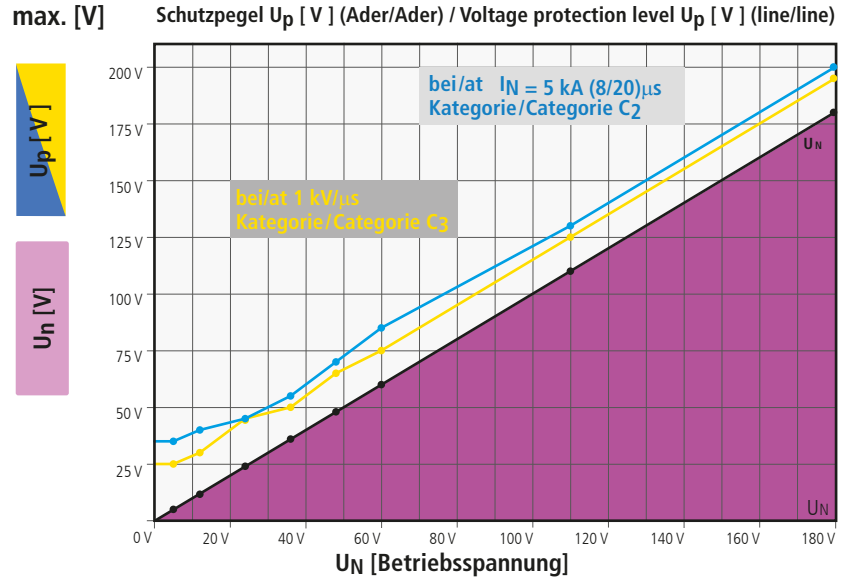
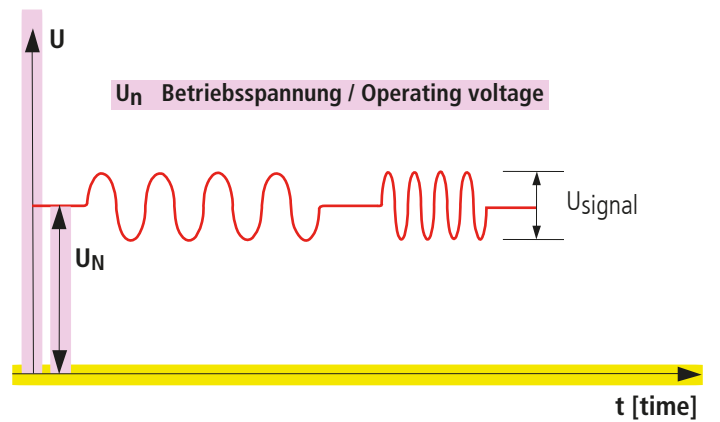

Diagram / Diagram 1



Oszillogramm / Oscillogram 1



Anwendung und Funktion

Das spannungsgesteuerte Schutzmodul BXTU ML2... / BXTU ML4... wird zusammen mit dem BXT BAS, 920 300 eingesetzt. Im eingesteckten Zustand paßt sich das Schutzmodul BXTU ML2... / BXTU ML4... selbsttätig an die eingespeiste Betriebsspannung (im Bereich: 0 ... 180 V) des zu schützenden Gerätes an. Im Beeinflussungsfall einer Überspannung stellt sich in Abhängigkeit der eingespeisten Betriebsspannung an den Ausgangsklemmen des BXT BAS ein resultierender Schutzpegel ein (s. Diagramm 1 und Oszillogramm 1).

Application and mode of operation

The voltage-controlled protection module BXTU ML2... / BXTU ML4... is used in combination with the standard BXT BAS, 920 300. If plugged in, the BXTU ML2... / BXTU ML4... protection module automatically adjusts itself to the operating voltage supplied (in the range from 0 to 180 V) of the device to be protected. In case of overvoltage, the voltage protection level adjusts itself depending on the operating voltage at the output terminals of the BXT BAS (see diagram 1 and oscillogram 1).

**⚠ Kurzschlussströme im Anlagenkreis auf 100 mA begrenzen!**  
**Limit short-circuit currents to 100 mA in the vicinity of the installation.**

**Betriebsspannung / Operating voltage:**  
 $U_N = [0 \dots 180 \text{ V}]$   
 $f_{U_N} \leq 400 \text{ Hz}$   
 $I_L \leq 100 \text{ mA}$

**Signalspannung / Signal voltage:**  
 $U_{\text{signal}} \leq \pm 5 \text{ V}$   
 $f_g \text{ signal} = 25 \text{ MHz}$



1. These modules are intended for ordinary indoor use on communication loop circuits that are isolated from the Public Switched Telephone Network.
2. The protector module shall be secured to the compatible protector base before applying power to the communication loop.
3. The protector base shall be secured to a compatible DIN Rail ground bar using the methods described in this instruction.
4. Proper grounding continuity shall be determined.
5. If a replacement module is needed, deactivate power to the communication loop and only use a Listed protector module having the same rated voltage breakdown range.
6. Please install the protector modules in accordance with the applicable requirements of the National Electrical Code, Article 800 or other applicable local codes.
7. Performance testing has not been conducted on the LifeCheck function by Underwriters Laboratories.
8. Screw Terminal Ratings with the applicable wire gauge sizes shall be noted.
9. The maximum circuit current for UL 497 B application is limited to 100 mA.

| Tabulation Strike voltage in accordance with UL 497 B (Protectors for Data Communication and Fire Alarm Circuits) |          |                                |               |  |               |                                     |               |  |              |
|---|----------|--------------------------------|---------------|--|---------------|-------------------------------------|---------------|--|--------------|
| Blitzductor BXT U ML4   |          | Strike voltage 100 Volts / sec |               |  |               | Surge voltage 100 Volts / $\mu$ sec |               |  |              |
| Type  | Part No. | Line to Ground                 |               | Line to Line<br>Line 1/1' to Line 2/2'<br>Line 3/3' to Line 3/3' |               | Line to Ground                      |               | Line to Line<br>Line 1/1' to Line 2/2'<br>Line 3/3' to Line 3/3' |              |
| BXTU ML4 BD 0-180   | 920 349  | min.<br>182 V                  | max.<br>278 V | min.<br>182 V  | max.<br>240 V | min.<br>182 V                       | max.<br>550 V | min.<br>6 V  | max.<br>25 V |

| Tabulation Strike voltage in accordance with UL 497 B (Protectors for Data Communication and Fire Alarm Circuits) |          |                                |               |               |               |                                     |               |               |              |
|---|----------|--------------------------------|---------------|---------------|---------------|-------------------------------------|---------------|---------------|--------------|
| Blitzductor BXT U ML2<br>Signal Lines 1/1' and 2/2'   |          | Strike voltage 100 Volts / sec |               |               |               | Surge voltage 100 Volts / $\mu$ sec |               |               |              |
| Type  | Part No. | Line to Ground                 |               | Line to Line  |               | Line to Ground                      |               | Line to Line  |              |
| BXTU ML2 BD S 0-180   | 920 249  | min.<br>182 V                  | max.<br>278 V | min.<br>182 V | max.<br>240 V | min.<br>182 V                       | max.<br>550 V | min.<br>6 V   | max.<br>25 V |
| Blitzductor BXT U ML2 Shielding Lines 3/3'  |          | Strike voltage 100 Volts / sec |               |               |               | Surge voltage 100 Volts / $\mu$ sec |               |               |              |
| Type  | Part No. | Line to Ground                 |               |               |               | Line to Ground                      |               |               |              |
| BXTU ML2 BD S 0-180   | 920 249  | min.<br>70 V                   |               | max.<br>110 V |               | min.<br>70 V                        |               | max.<br>150 V |              |

