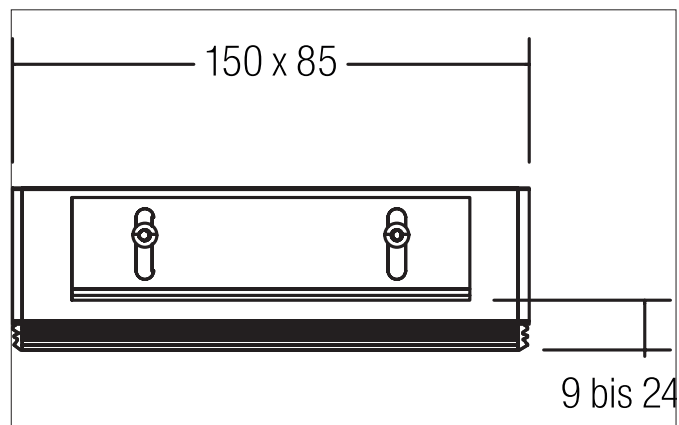

COUPLED Double plaster frame, square, for frameless mounting

Artikel-Nr. 82043170

Licht.
Für Generationen.**Tender**

Double plaster frame, square, for frameless mounting, white, rectangular. In a compact design, for installation in tool-less rapid assembly systems. Dual plaster frame for recessed ceiling lights COUPLED as the basis for 12640/12645, 12642/12644 and 12641/12643. Mounting method: Recessed mounting, Place of installation: Ceiling-mounted, Material: Aluminium.

Article data	
Artikel-Nr.	82043170
GTIN	4251433916017
Series name	COUPLED
Kurzbeschreibung	Double plaster frame, square, for frameless mounting
Material	Aluminium
Colour	White
Type of surface	Structure
Shape	rectangular
Built-in width	150 mm
Built-in length	85 mm
Length	143 mm
Width	83 mm
weight	0.332 kg

Lighting technology**Operating technology of the luminaires**

COUPLED Double plaster frame, square, for frameless mounting
Artikel-Nr. 82043170Licht.
Für Generationen.

Mounting technology	
Mounting method	Recessed mounting
Place of installation	Ceiling-mounted
Adjustability	Not adjustable

Packing data	
Gross weight	0.375 kg
Length of packaging	150 mm
Packaging width	85 mm
Packaging height	50 mm