

## LED power supply unit 24 V DC, DALI-2 dimmable

Article no. 17251000

Light.  
For Generations.

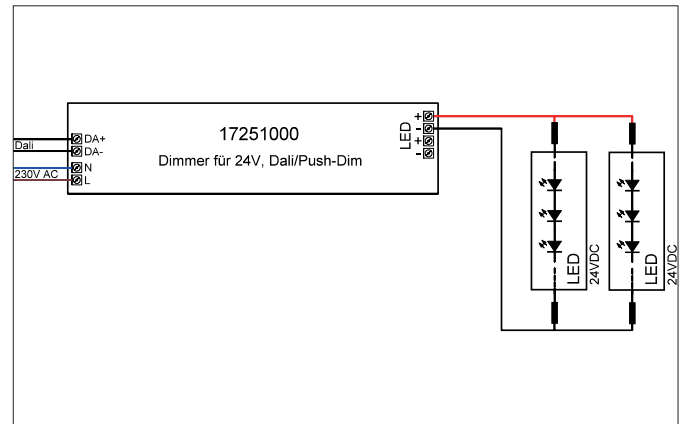

### Tender

LED power supply unit 24 V DC, DALI-2 dimmable, , Rectangular. Material: Plastic, Degree of protection: according to DIN EN 60529 IP20, Protection class: (EN 61140) II, Power: 80 W, Dimmable: Yes, Control: DALI-2 .

### Product Benefits

- Plastic housing incl. strain relief
- protection class II
- dimmable via DALI-2
- Measuring point Tc (max) 85°C

Article data	
Article no.	17251000
GTIN	4251433955245
Short description	LED power supply unit 24 V DC, DALI-2 dimmable
Material	Plastic
Colour	White
Shape	Rectangular
Length	290 mm
Width	45 mm
Height	31 mm
Weight	0.297 kg
stamp	ENEC 05, MM

**LED power supply unit 24 V DC, DALI-2 dimmable**

Article no. 17251000

Light.  
For Generations.

Operating technology of driver	
AC nominal voltage min	198 V
AC nominal voltage max	264 V
Frequency min	50 Hz
Frequency max	60 Hz
DC nominal voltage min	176 V
DC nominal voltage max	264 V
Protection class	II
Degree of protection	IP20
max. no. lights on C16 A	15
max. no. lights on B16 A	12
Starting current	50A Max./300µs@230V, Full Load
Power min	1 W
Power max.	80 W
Suitable for emergency lighting	No
Control	DALI-2 , PUSH-Dimm
Flicker-free	Yes
Average nominal lifespan	44000 h
Power factor	0.95

Packing data	
Gross weight	0.337 kg
Length of packaging	330 mm
Packaging width	50 mm
Packaging height	37 mm
Disposal at end of life	This product must not be disposed of with household waste. You are obliged, to dispose of such electrical waste separately. By disposing of electrical waste and other old or defective electronics separately, you support recycling or other forms of re-use. In that way you help to take care and to avoid that harmful substances get into the environment.