

EMC9999 FOUNDATION FOR EMC2 AND EMC3 CHARGING POLES

For ground installation of the eMC2 and eMC3 charging poles, ABL offers the EMC9999 precast foundation block, which provides the necessary stability and security for the charging pole and has an integrated tube to protect the power supply. The foundation block is made from grade C 30/37 concrete and complies with exposure classes XC4 and XF1. The mounting screws M12 V2A (4 pcs.) are included in the scope of delivery.

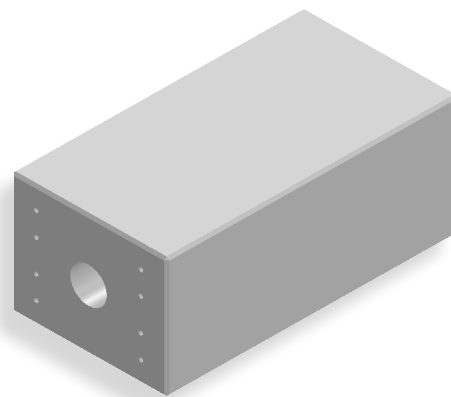

General information

Model	Prefabricated foundation
Product number	EMC9999
EAN	4011721171692
Commodity code	68109100
Packaging unit (PU)	1 unit
Items supplied	Concrete foundation, installation kit

Product information

Fixing type	Anchorage to the ground
Material	Reinforced concrete
Grade	C30/37
Exposure class	XC4 and XF1
Product dimensions (HxWxD)	800 x 338 x 426 mm
Packaging dimensions	Pallet shipping without packaging
Weight per unit	approx. 265 kg

Optional accessories

eMC2 plinth 160 mm	EMC9998
eMC2 plinth 100 mm	EMC9997
eMC3 plinth 160 mm	EMC9996
eMC3 plinth 100 mm	EMC9994

Dimensioned drawing

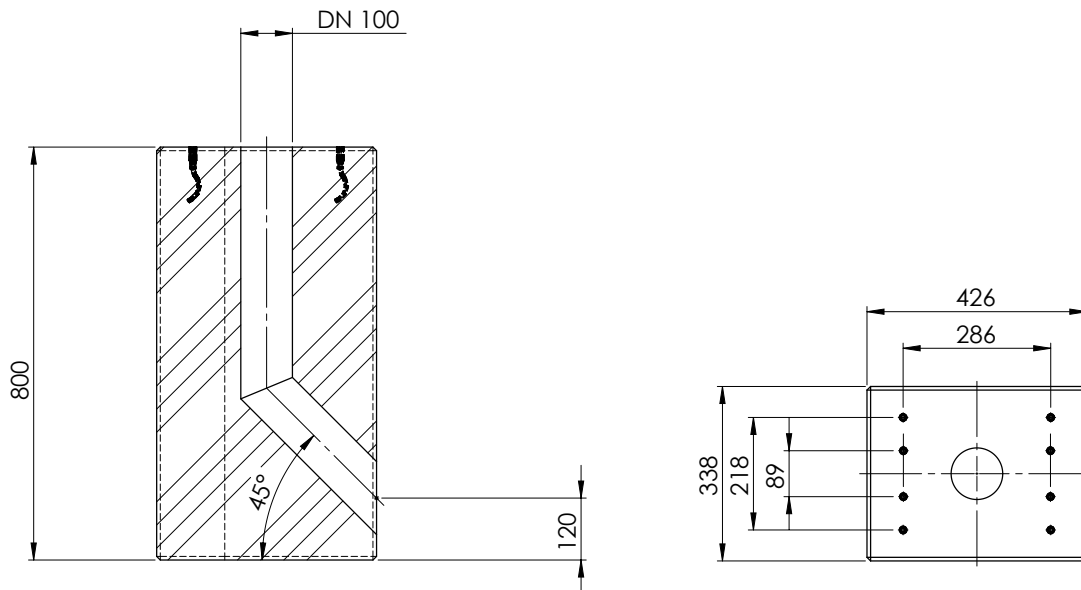

Subject to change: All performance characteristics, technical and other specifications are subject to change without prior notice.