

CONTROL UNIT 1V0001

FOR CONTROLLER/EXTENDER APPLICATIONS

The 1V0001 external control unit is specially designed for use in group solutions based on the Controller/Extender principle, which are billed via a backend. It replaces the controller wallbox and then takes over the configuration and control of up to 16 charging points in the form of eMH2 or eMH3 extender wallboxes. Integrated load management intelligently distributes the total charging current available from the domestic power installation to all charge points in the system. Its backend communication via OCPP makes the 1V0001 external control unit particularly suitable for use in semi-public and public applications.



General information

Model	External control unit
Product number	1V0001
EAN number	4011721175034
Commodity code	85371091
Packaging unit (PU)	1 unit
Packaging (dimensions HxWxD)	370 × 285 × 170 mm
Items supplied	Control unit, installation kit

Input/mains supply

External power supply	for supply cable sizes up to 2 × 50 mm ² (RCCB) and 1 × 4 mm ² (PE)
Rated voltage	230 V
Rated current	0,2 A (40 A inrush current)
Rated frequency	50 Hz
Upstream fuse	not required
Terminal blocks	Direct connection to RCD PE to terminal block
Cable entry	1 × M32 (top side) and 2 × M32 (bottom side)

Protection/integrated components

RCCB	Type A RCD, 30 mA
MCB	B characteristic, 6 A, 1+N

Charge monitoring

Backend communication	OCPP 1.5 and 1.6 via LAN or LTE/WIFI (optional)
-----------------------	---

Standards/guidelines

IEC 61439-1

Operating conditions

Operating temperature	-30 to 40°C
Storage temperature	-30 to 85°C
Relative humidity	5 to 95%, no condensation
Class of protection	I
Overvoltage category	III
Degree of pollution	3
IP rating	IP44
Maximum elevation	≤ 2,000 m AMSL
Power dissipation	4.5 W

Housing

Type	Wall-mounted housing
Fixing type	Wall bracket (mounting kit provided)
Material (housing)	Plastic
Housing colour	Anthracite
Material (cover)	Plastic
Cover colour	Light grey
Locking mechanism	Metric screw with knurled plastic head
Dimensions (HxWxD)	320 × 205 × 146 mm
Weight (net)	approx. 2 kg
Weight (gross)	approx. 3.5 kg

Optional accessories

Configuration kit	CONF CAB
LTE accessory package	E3BLTE1
WLAN accessory package	E3BWLAN
see website at www.ablmobility.de	

Dimensioned drawing

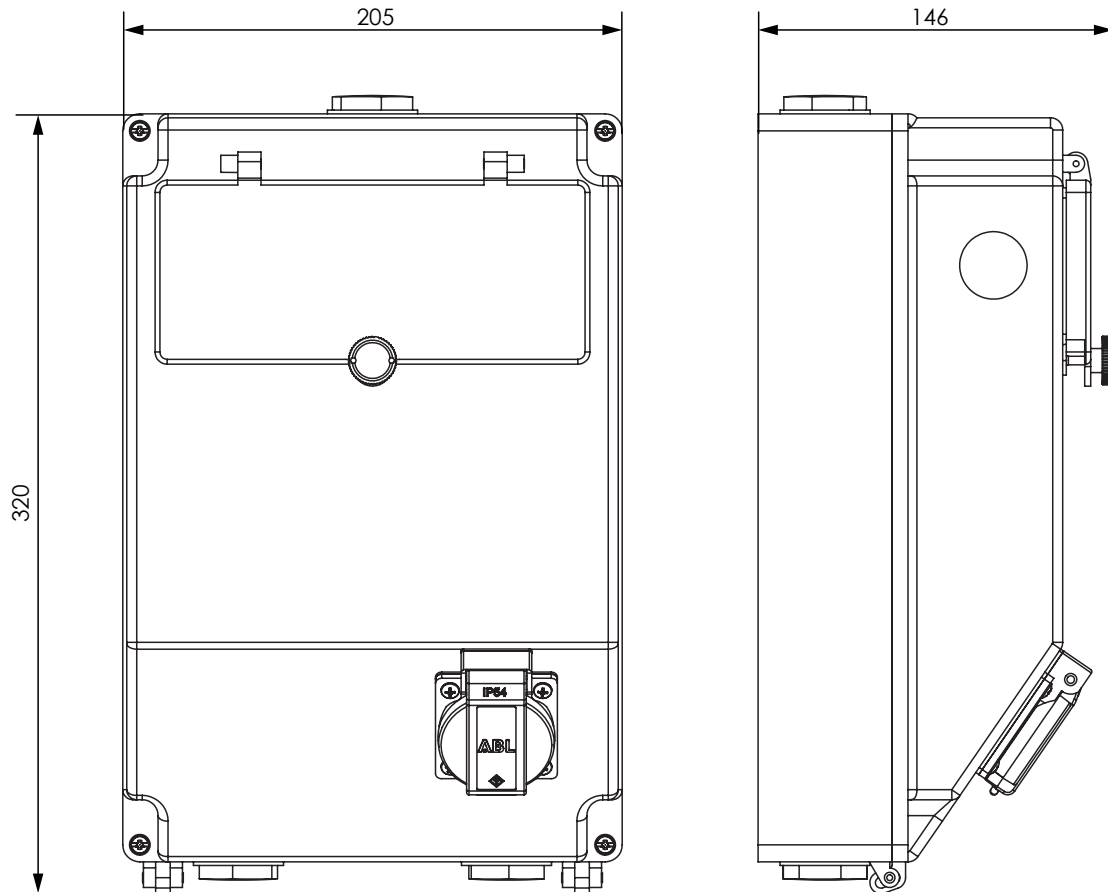

Subject to change: All performance characteristics, technical and other specifications are subject to change without prior notice.