

WHEMH10 MOUNTING PLATE

The WHEMH10 mounting plate is a wall bracket for all eMH1 Wallboxes. At the same time, the mounting plate serves as a storage holder for coiling up the charging cable. All screws and wall plugs required for installation are included.



General information

Model	Bracket
Product number	WHEMH10
EAN number	4011721169453
Commodity code	85381000
Packaging unit (PU)	1 unit
Items supplied	Wall bracket, mounting kit, drilling template

Operating conditions

Storage temperature	-30 to 85°C
Operating temperature	-30 to 50°C
Relative humidity	10 to 90%, no condensation
Degree of protection (housing)	IP43

Housing

Type	Wall bracket with integrated cable storage holder
Fixing type	Plug and screw fixing (screws included)
Compatibility	ABL eMH1 Wallbox
Material	Plastic
Housing colour	black, similar to RAL9005
Dimensions (HxWxD)	482 x 226 x 93 mm
Weight	approx. 1.5 kg

Dimensioned drawing

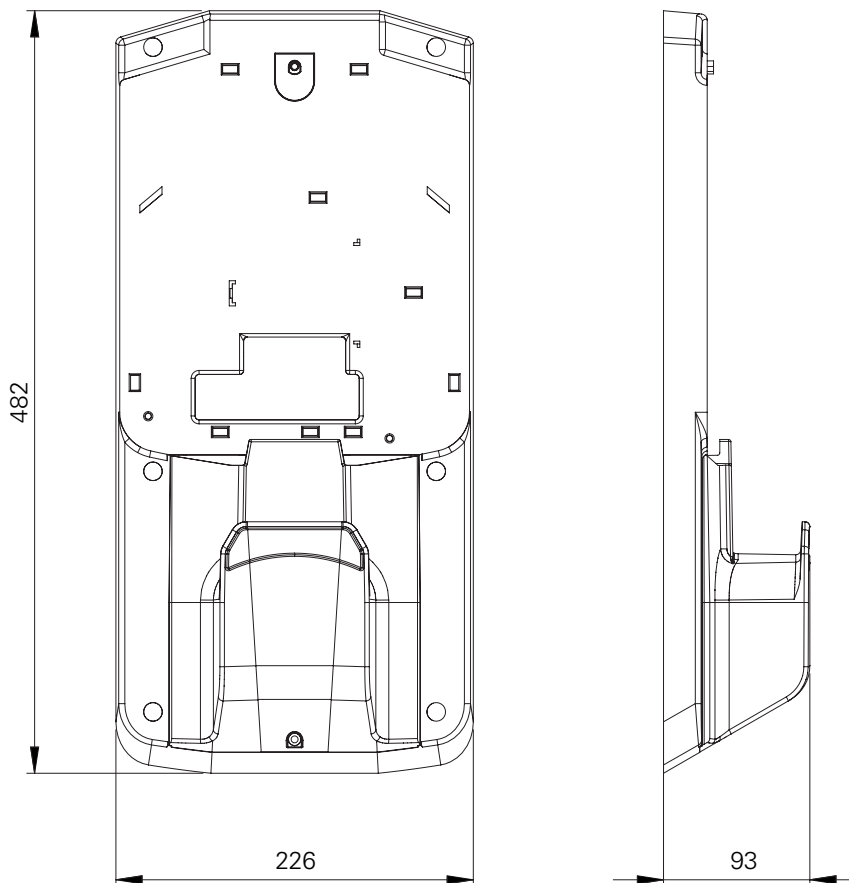

Subject to change: All performance characteristics, technical and other specifications are subject to change without prior notice.