

WALLBOX eMH3

TWIN EXTENDER+ WITH CHARGING CABLES & reev Dashboard Compact 22 kW

The calibration law compliant Wallbox eMH3 has two fixed charging cables with Type 2 charging connectors. Thanks to its ability to charge two vehicles simultaneously, and Dashboard Compact by reev for monitoring, it is the smart charging solution for semi-public and public applications. In multiple unit installations up to 7 Wallboxes eMH3 extender can be connected to one controller unit. Alternatively, the Wallbox eMH3 can be configured for stand-alone use using the software provided. With a Type A residual current circuit breaker (RCCB) and DC fault current detection integrated as standard, the wallbox with backend is pre-installed for connection by the installing technician and ready for immediate use. The Wallbox eMH3 with Dashboard Compact is 'Made in Germany' and offers the highest safety standards available.



General information

Model	eMH3
Product number	3W2254C
EAN number	4011721183251
Commodity code	85371091
Packaging unit (PU)	1 unit
Packaging (dimensions HxWxD)	736 x 487 x 381 mm
Items supplied	Wallbox, printed operating manual, 1 triangular key, installation kit, 2 reev RFID cards, 2 reev QR codes

Input/mains supply

External power supply	Supply cables up to a maximum of 16 mm ² or cable diameters ≤ 25 mm
Rated voltage	230/400 V
Rated current	32 A
Rated frequency	50 Hz
Upstream fuse	32 A (required onsite), C characteristic recommended
Terminal blocks	Direct connection to RCCB PE: feed-through terminal block

Output/vehicle connection

Connection system	Two charging cables with Type 2 connectors in acc. with IEC62196-2, approx. 6 m
Output voltage	230/400 V
Max. charging current	32 A
Maximum output	2 x 11 kW or 1 x 22 kW

Protection/integrated components

RCCB	RCCB, type A, 30 mA
DC fault current detection	electronic, $I_{\Delta n \text{ d.c.}} \geq 6 \text{ mA}$
Energy meter	MID compliant
Compliance module	Logging Gateway (LGW)
Load switching	Installation contactor, 4-pole, 40 A
Weld detection	Contactors welding switches off the charging point
Overcurrent protection	Integrated into firmware, disconnection at 110% after 100 seconds, at 120% after 10 seconds
Temperature monitoring	internal, charging current reduction or shut down

Charge monitoring/status indicators

Operating status indicator	LED
Access control	RFID card, QR code or smartphone app
Communication EV	in acc. with IEC 61851-1 Mode 3
Communication Controller/Extender	RS485

Software/Backend

Backend communication	Via controller wallbox
Access control	Unlimited driver and vehicle access rights allocated via RFID cards
Smartphone app for drivers	Entering payment and invoicing details, accessing transaction histories, available for Android and iOS
Management & monitoring	Simple and user-friendly administration of EV charging infrastructure networks across several sites via the online dashboard
Analytics	Clear visual representations of charging procedure and consumer behaviour analyses
EV charging with consumption monitoring	Cost monitoring for company cars and fleet vehicles, exporting charging histories
Software updates	Automatic and free software updates

Standards/guidelines

IEC 61851-1
IEC 61439-7 ACSEV
in acc. with MessEV Modul B

Operating conditions

Storage temperature	-30 to 85°C
Operating temperature	-25 to 40°C
Relative humidity	5 to 95%, no condensation
Class of protection	I
Overvoltage category	III
Degree of pollution	3
Degree of protection (housing)	IP54
Impact strength	IK08
Maximum elevation	≤ 2,000 m AMSL
Power dissipation	7 W

Housing

Type	Wall-mounted housing
Fixing type	Wall installation using mounting plate and installation kit
Material (housing/cover)	Plastic
Housing colour	black, similar to RAL9011
Cover colour	silver, similar to RAL9006 / black, similar to RAL9017
Locking mechanism	integrated triangular key lock
Dimensions (HxWxD)	492 x 394 x 192 mm (housing base without overhangs)
Weight (net)	approx. 21 kg

Optional accessories

Pole	POLEMH3
Foundation block for pole	EMH9999
Double pole	POLEMH6
Foundation block for double pole	EMH9996
Weather protection roof	WPR36
Cable storage holder with charging plug adapter	CABHOLD
Configuration kit	CONFCAB
RFID card	E017869, 5 pcs
Multi-purpose installation tester	TE001
Vehicle simulation adapter	TE002
see website at www.ablmobility.de	

Dimensioned drawing

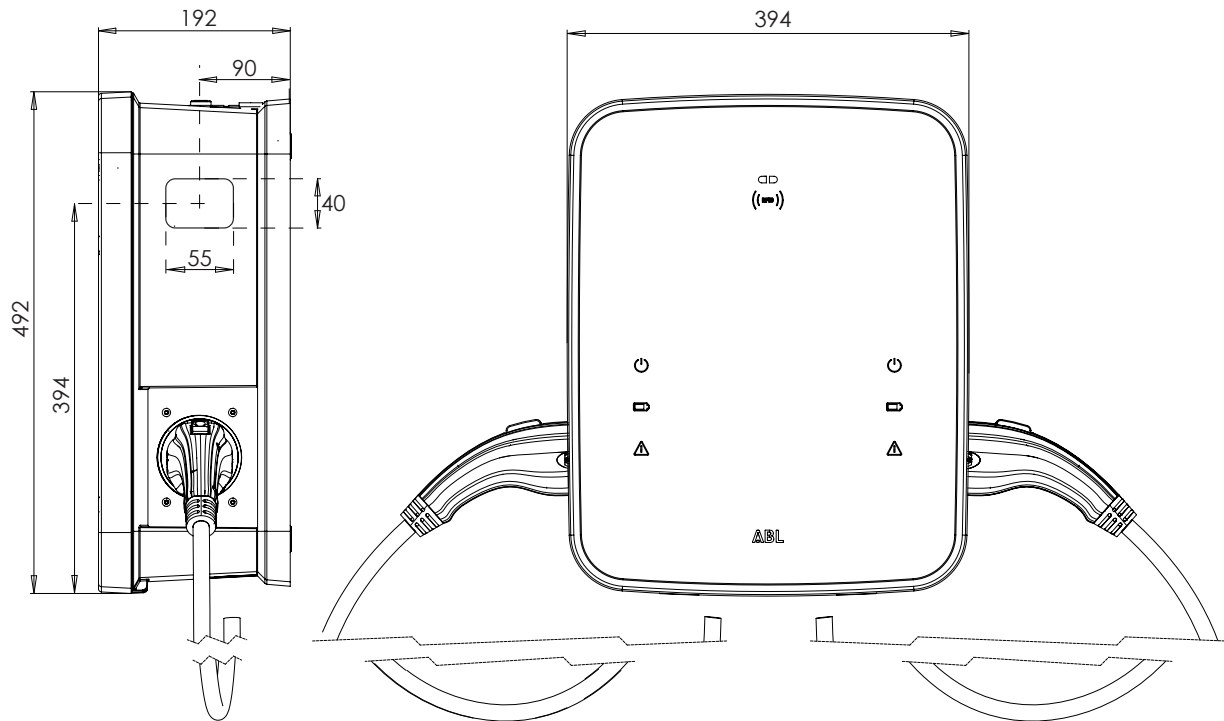

Subject to change: All performance characteristics, technical and other specifications are subject to change without prior notice.

ABL SURSUM
Bayerische Elektrozubehör GmbH & Co. KG

Albert-Büttner-Straße 11
D-91207 Lauf / Pegnitz

Phone +49 (0) 9123 188-0
Fax +49 (0) 9123 188-188

info@abl.de
www.ablmobility.de

reev
by emonvia GmbH

Theo-Prosel-Weg
D-80797 München

Phone +49 (0) 89 215 389 70

sales@reev.com
www.reev.com