

eMH2 WALLBOX CONTROLLER WITH CHARGING SOCKET & reev Dashboard Basic 22 kW

The Wallbox eMH2 features an integrated Type 2 charging socket. In combination with the reev Dashboard Basic, it is the intelligent charging solution for private and semi-public applications. In group installations, the controller wallbox takes care of all necessary communication functions with the reev Dashboard. The included 24-month reev Dashboard Basic enables future-proof operation, regular software updates, as well as flexible user and RFID management. The Dashboard can also be upgraded at any time. With a Type A residual current circuit breaker (RCCB) and DC fault current detection integrated as standard, the wallbox with Dashboard is pre-installed for connection by the installing technician and ready for immediate use. The Wallbox eMH2 with reev Dashboard Basic is 'Made in Germany' and offers the highest safety standards available.



General information

Model	eMH2
Product number	2W2240B
EAN number	4011721180434
Commodity code	85371091
Packaging unit (PU)	1 unit
Packaging (dimensions HxWxD)	740 x 380 x 217 mm
Items supplied	Wallbox, printed operating manual, installation kit, drilling template, 1 key, 2 reev RFID cards, 1 reev QR code, SIM card, reev onboarding letter

Input/mains supply

External power supply	max. 5 x 16 mm ²
Rated voltage	230/400 V (3-phase)
Rated current	32 A
Rated frequency	50 Hz
Upstream fuse	max. 32 A (required onsite), C characteristic recommended
Terminal blocks	Direct connection to RCD PE to terminal block

Output/vehicle connection

Connection system	Single lockable Type 2 charging socket in acc. with IEC62196-2
Output voltage	230/400 V
Max. charging current	32 A
Maximum output	22 kW

Protection/integrated components

RCCB	Type A RCD, 30 mA
DC fault current detection	electronic, $I_{\Delta n \text{ d.c.}} \geq 6 \text{ mA}$
Energy meter	MID conform (visible through lateral window)
Load switching	Contactors, 4-pole
Weld detection	Contactors welding trips RCD
Overcurrent protection	Integrated into firmware, disconnection at 110% after 100 seconds, at 120% after 10 seconds
Temperature monitoring	internal, charging current reduction or shut down

Charge monitoring/status indicators

Display (operating state/error codes)	LED
Access control	RFID card, QR code or smartphone app
Communication	in acc. with IEC 61851-1 Mode 3
Communication Controller/Extender	RS485
Backend communication	LAN, LTE, OCPP 1.6

Software/Backend

Access control	Driver and vehicle access rights allocated via RFID cards
Software updates	Automatic and free software updates

Operating conditions

Storage temperature	-30 to 85°C
Operating temperature	-25 to 40°C
Relative humidity	5 to 95%, no condensation
Class of protection	I
Overvoltage category	III
Degree of pollution	3
Degree of protection (housing)	IP54
Impact strength	IK08
Maximum elevation	$\leq 2,000 \text{ m AMSL}$
Power dissipation	n/a

Standards/guidelines

IEC 61851-1

IEC 61439-7

IEC 62196-1

IEC 62196-2

Housing

Type	Wall-mounted housing (can be used for cable storage)
Fixing type	Wall bracket (mounting kit provided)
Material (housing/cover)	Plastic
Housing colour	black, RAL9011
Cover colour	black, translucent
Locking mechanism	Lockable cover with safety screw
Dimensions (HxWxD)	437 × 328 × 170 mm
Weight (net)	approx. 8 kg
Weight (gross)	approx. 10 kg

Optional accessories

Pole	POLEMH2
Foundation	EMH9999
Weather protection roof	WPR12
Cable storage holder with charging plug adapter	CABHOLD
Type 2 charging cable	LAK32A3, 32 A 240/415 V, length approx. 4 m
Type 2 charging cable	LAK32A3, 32 A 240/415 V, length approx. 7 m
Type 2 to Type 1 adapter cable	LAKK2K1, 32 A 230 V, length approx. 4 m
Configuration kit	CONFACAB
RFID card	E017869, 5 pcs
Multi-purpose installation tester	TE001
Vehicle simulation adapter	TE002
see website at www.ablmobility.de	

Dimensioned drawing

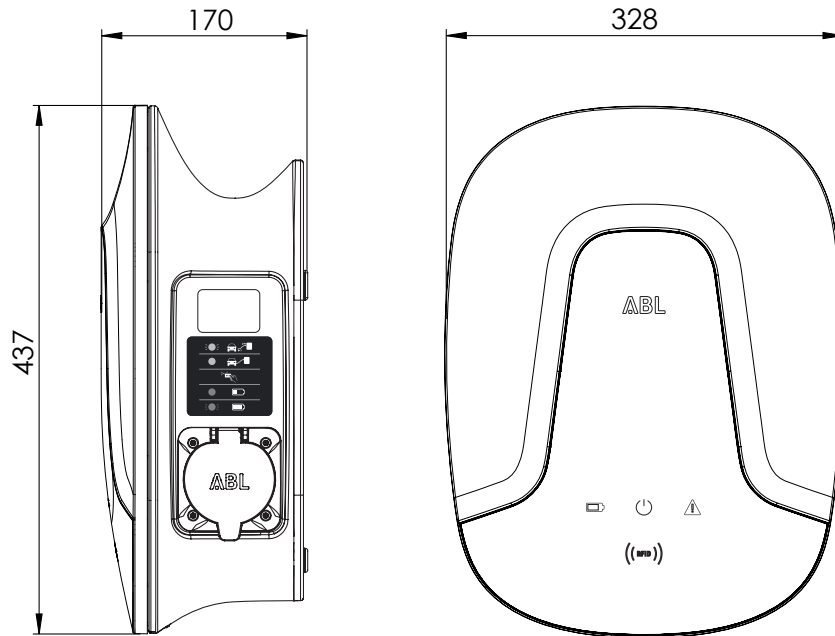

Subject to change: All performance characteristics, technical and other specifications are subject to change without prior notice.

ABL SURSUM
Bayerische Elektrozubehör GmbH & Co. KG

Albert-Büttner-Straße 11
D-91207 Lauf / Pegnitz

Phone +49 (0) 9123 188-0
Fax +49 (0) 9123 188-188

info@abl.de
www.ablmobility.de

reev
by emonvia GmbH

Theo-Prosel-Weg
D-80797 München

Phone +49 (0) 89 215 389 70

sales@reev.com
www.reev.com