

# eMH2 WALLBOX EXTENDER WITH CHARGING CABLE & reev Dashboard Basic 22 kW

The Wallbox eMH2 features a fixed charging cable with Type 2 charging connector. In combination with the reev Dashboard Basic, it is the intelligent charging solution for private and semi-public applications. In multiple unit installations up to 15 Wallboxes eMH2 extender can be connected to one controller unit. Alternatively, the Wallbox eMH2 can be configured for stand-alone via software. With a Type A residual current circuit breaker (RCCB) and DC fault current detection integrated as standard, the wallbox with Dashboard is pre-installed for connection by the installing technician and ready for immediate use. The Wallbox eMH2 with reev Dashboard Basic is 'Made in Germany' and offers the highest safety standards available.



## General information

Model	eMH2
Product number	2W2231B
EAN number	4011721180403
Commodity code	85371091
Packaging unit (PU)	1 unit
Packaging (dimensions HxWxD)	740 x 380 x 217 mm
Items supplied	Wallbox, printed operating manual, installation kit, drilling template, 1 key, 2 reev RFID cards, 1 reev QR code

## Input/mains supply

External power supply	max. 5 x 16 mm <sup>2</sup>
Rated voltage	230/400 V (3-phase)
Rated current	32 A
Rated frequency	50 Hz
Upstream fuse	max. 32 A (required onsite), C characteristic recommended
Terminal blocks	Direct connection to RCD PE to terminal block

## Output/vehicle connection

Connection system	Single charging cable with Type 2 connector in acc. with IEC62196-2, ca. 6.35 m
Output voltage	230/400 V
Max. charging current	32 A
Maximum output	22 kW

## Protection/integrated components

RCCB	Type A RCD, 30 mA
DC fault current detection	electronic, $I_{\Delta n \text{ d.c.}} \geq 6 \text{ mA}$
Energy meter	MID conform (visible through lateral window)
Load switching	Contactor, 4-pole
Weld detection	Contactor welding trips RCD
Overcurrent protection	Integrated into firmware, disconnection at 110% after 100 seconds, at 120% after 10 seconds
Temperature monitoring	internal, charging current reduction or shut down

## Charge monitoring/status indicators

Display (operating state/error codes)	LED
Access control	RFID card, QR code or smartphone app
Communication	in acc. with IEC 61851-1 Mode 3
Communication Controller/Extender	RS485

## Software/Backend

Backend communication	Via controller wallbox
Access control	Driver and vehicle access rights allocated via RFID cards
Software updates	Automatic and free software updates

## Operating conditions

Storage temperature	-30 to 85°C
Operating temperature	-25 to 40°C
Relative humidity	5 to 95%, no condensation
Class of protection	I
Overvoltage category	III
Degree of pollution	3
Degree of protection (housing)	IP54
Impact strength	IK08
Maximum elevation	$\leq 2,000 \text{ m AMSL}$
Power dissipation	n/a

## Standards/guidelines

IEC 61851-1

IEC 61439-7

IEC 62196-1

IEC 62196-2

## Housing

Type	Wall-mounted housing (can be used for cable storage)
Fixing type	Wall bracket (mounting kit provided)
Material (housing/cover)	Plastic
Housing colour	black, RAL9011
Cover colour	black, translucent
Locking mechanism	Lockable cover with safety screw
Dimensions (HxWxD)	437 × 328 × 170 mm
Weight (net)	approx. 10 kg
Weight (gross)	approx. 12 kg

## Optional accessories

Pole	POLEMH2
Foundation	EMH9999
Weather protection roof	WPR12
Cable storage holder with charging plug adapter	CABHOLD
Configuration kit	CONFCAB
RFID card	E017869, 5 pcs
Multi-purpose installation tester	TE001
Vehicle simulation adapter	TE002
see website at <a href="http://www.ablmobility.de">www.ablmobility.de</a>	

## Dimensioned drawing

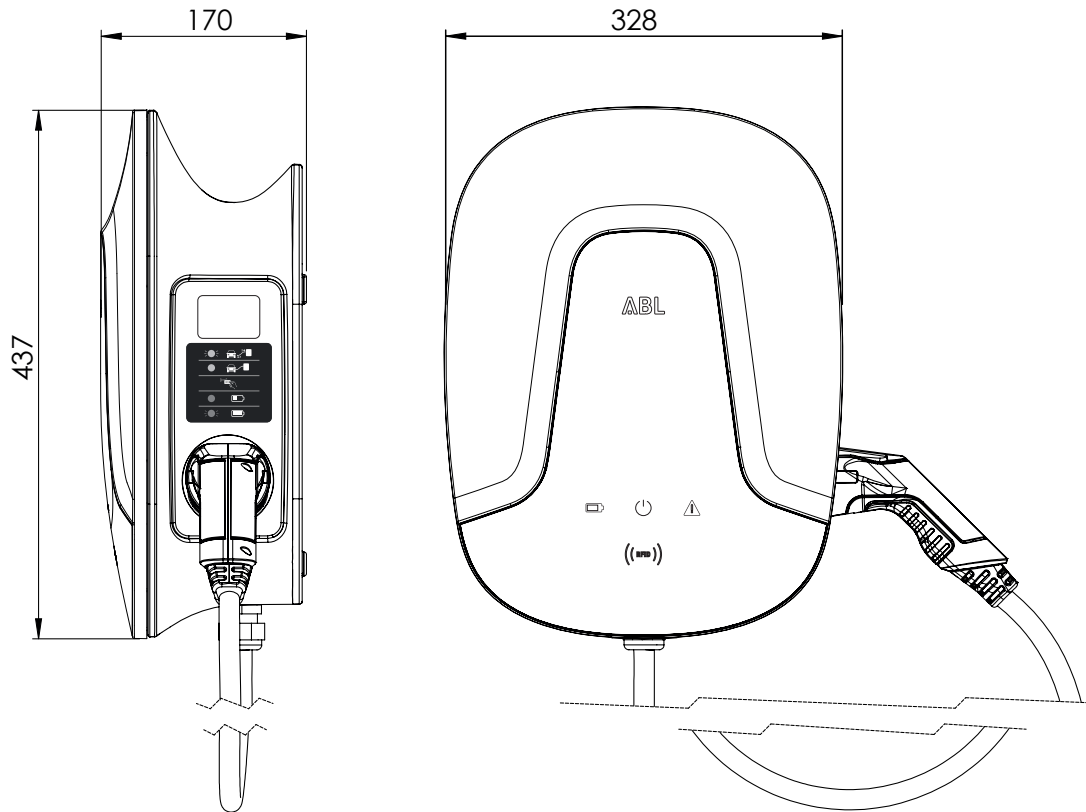

Subject to change: All performance characteristics, technical and other specifications are subject to change without prior notice.

ABL SURSUM  
Bayerische Elektrozubehör GmbH & Co. KG

Albert-Büttner-Straße 11  
D-91207 Lauf / Pegnitz

Phone +49 (0) 9123 188-0  
Fax +49 (0) 9123 188-188

info@abl.de  
www.ablmobility.de

reev  
by emonvia GmbH

Theo-Prosel-Weg  
D-80797 München

Phone +49 (0) 89 215 389 70

sales@reev.com  
www.reev.com