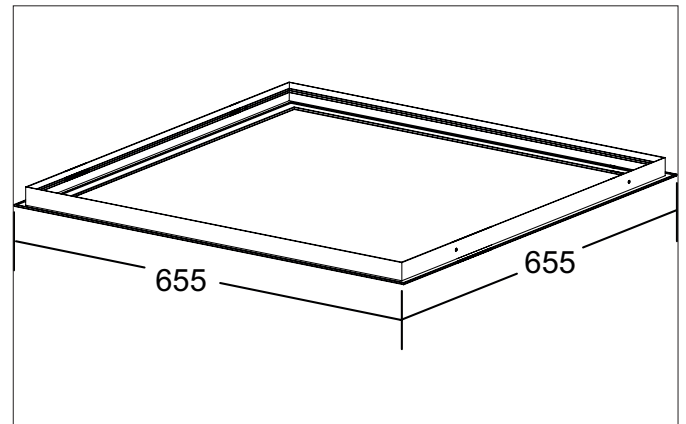
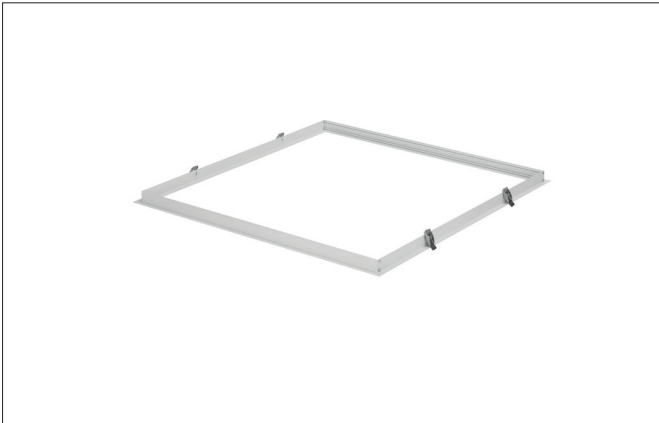

**PINOS Installation frame 1-piece, 655 x 655 x 30 mm, white**

Article no. 81032050

Light.  
For Generations.

Tender	
Installation frame 1-piece, 655 x 655 x 30 mm, white. Material: Aluminium / Steel, .	

Article data	
Article no.	81032050
GTIN	4251433999867
Series name	PINOS
Short description	Installation frame 1-piece, 655 x 655 x 30 mm, white
Material	Aluminium / Plastic
Colour	White
Length	655 mm
Width	655 mm
Hight	30 mm
Weight	0.550 kg

Packing data	
Gross weight	0.55 kg
Length of packaging	680 mm
Packaging width	330 mm
Packaging hight	680 mm
Disposal at end of life	This product must not be disposed of with household waste. You are obliged, to dispose of such electrical waste separately. By disposing of electrical waste and other old or defective electronics separately, you support recycling or other forms of re-use. In that way you help to take care and to avoid that harmful substances get into the environment.