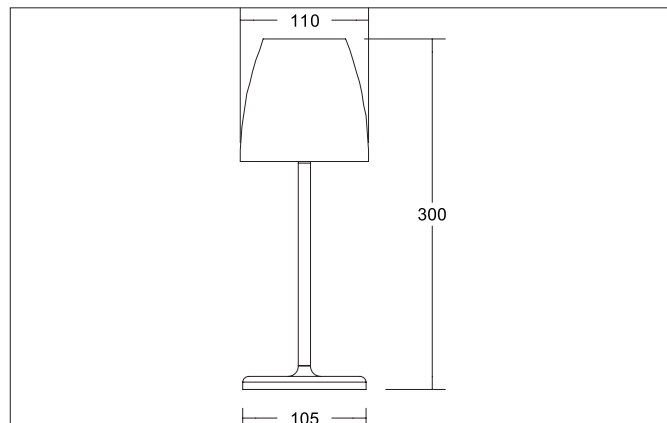

CAMERON LED solar table lamp, IP54, height 300 mm

Article no. 60331183

Light.
For Generations.**Tender**

LED solar table lamp, IP54, height 300 mm, Other., Hight 300.0 mm Weight 0.889 kg, with rotattionssymmetrical, deep, wide distributed light intensity.. Power 1 x 1,5 W, Colour rendering index CRI > 80, Housing material: Aluminium / Polycarbonate, Colour: Black, Permissible ambient temperature (ta): -20 °C - +25 °C, Protection class (EN 61140): III, Degree of protection (DIN EN 60529): IP54. With electronic driver, Other dimmable.

Product Benefits

Charging time solar: 20 hours.

Charging time USB-C: 4.5 hrs.

Working time: 7.5 hrs.

CAMERON LED solar table lamp, IP54, height 300 mm

Article no. 60331183

Light.
For Generations.

Article data	
Article no.	60331183
GTIN	4255752507758
Series name	CAMERON
Short description	LED solar table lamp, IP54, height 300 mm
Material	Aluminium / Polycarbonate
Colour	Black
Type of surface	Matt
Shape	Other
Hight	300 mm
Scope of delivery	incl. USB-C charging cable - Charging time: 4.5 hours - Running time: 7.5 hrs.
Weight	0.889 kg
Conformance	CE, UKCA

Lighting technology	
Colour temperature	3.000 K
Light colour	White
Light output	Direct
Luminous flux	150 lm
System efficiency	2 lm/W
Colour rendering	CRI > 80
Beam angle	145°
Light sharing	Symmetric
Adjustable color temperature	No

Operating technology of the luminaire	
System output	2.2 W
Voltage type	DC
Lamp	LED
Protection class	III
Degree of protection	IP54
Control	Other
Bulb change possible	The light source of this luminaire may only be replaced by the manufacturer or a service technician commissioned by him or a similarly qualified person.

Mounting technology	
Mounting method	Surface mounting
Place of installation	Table-mounted
Adjustability	Not adjustable
Further references	Outdoor
Suitable for through-wiring	No

Packing data	
Gross weight	1.02 kg
Length of packaging	120 mm
Packaging width	120 mm
Packaging height	310 mm
Disposal at end of life	This product must not be disposed of with household waste. You are obliged, to dispose of such electrical waste separately. By disposing of electrical waste and other old or defective electronics separately, you support recycling or other forms of re-use. In that way you help to take care and to avoid that harmful substances get into the environment.