

Rittal – The System.

Faster – better – everywhere.



Filterlüfter
Fan-and-filter unit
Ventilateur à filtre
Ventilator
Filterfläkt
Ventilatore-filtro
Ventilador con filtro
フィルターファン

3237.xxx
3238.xxx
3239.xxx
3240.xxx

3241.xxx
3243.xxx
3244.xxx
3245.xxx

Montage-, Installations- und Bedienungsanleitung
Assembly and operating instructions
Notice d'emploi, d'installation et de montage
Montage- en bedieningshandleiding
Montage- och hanteringsanvisning
Istruzioni di montaggio e funzionamento
Instrucciones de montaje y funcionamiento
取扱説明書

ENCLOSURES

POWER DISTRIBUTION

CLIMATE CONTROL

IT INFRASTRUCTURE

SOFTWARE & SERVICES

FRIEDHELM LOH GROUP



Contents

| | | | | | |
|----------|--|----------|-----------|---|-----------|
| 1 | Notes on documentation | 4 | 5 | Carrying out the electrical connection | 9 |
| 1.1 | Other applicable documents | 4 | 5.1 | Connecting the power supply | 9 |
| 1.2 | Retention of documents | 4 | 5.2 | Rotating the voltage connection | 9 |
| 1.3 | Symbols used | 4 | 5.3 | Changing the direction of airflow | 10 |
| 2 | Safety notes | 5 | 6 | Commissioning | 10 |
| 3 | Device description | 5 | 7 | Installing and changing the filter | 10 |
| 3.1 | Functional description | 5 | 8 | Inspection and maintenance | 11 |
| 3.1.1 | Main components | 5 | 9 | Storage and disposal | 11 |
| 3.1.2 | Control | 6 | 10 | Technical specifications | 12 |
| 3.1.3 | Safety equipment | 6 | 11 | Cut-out/drilling dimensions | 16 |
| 3.1.4 | Filter mats | 6 | 12 | EMC fan/outlet filter | 17 |
| 3.2 | Proper use | 6 | 13 | Connection diagrams | 18 |
| 3.3 | Scope of supply | 6 | 14 | EC declaration of conformity | 20 |
| 4 | Assembly and connection | 7 | | | |
| 4.1 | Choosing the installation site | 7 | | | |
| 4.2 | Assembly instructions | 7 | | | |
| 4.2.1 | General | 7 | | | |
| 4.2.2 | Layout of the components in the enclosure | 7 | | | |
| 4.3 | Fitting the fan-and-filter unit or outlet filter | 7 | | | |
| 4.3.1 | Cutting out the enclosure | 7 | | | |
| 4.3.2 | Fitting the fan-and-filter unit | 8 | | | |
| 4.4 | Notes on electrical connection | 8 | | | |
| 4.4.1 | Connection data | 8 | | | |
| 4.4.2 | Overvoltage protection and supply line load | 9 | | | |
| 4.4.3 | PE conductor connection | 9 | | | |

1 Notes on documentation

EN

1 Notes on documentation

These assembly instructions are aimed at

- tradespersons who are familiar with assembly and installation of the fan-and-filter unit
- trained specialists who are familiar with operation of the fan-and-filter unit

1.1 Other applicable documents

Assembly and operating instructions exist as paper documents and/or on CD-ROM for the unit types described here and are enclosed with the equipment.

We cannot accept any liability for damage associated with failure to observe these instructions. Where applicable, the instructions for any accessories used also apply.

1.2 Retention of documents

These instructions and all associated documents constitute an integral part of the product. They must be given to the plant operator. The operator is responsible for storage of the documents so they are readily available when needed.

1.3 Symbols used

- **The bullet point indicates an action to be performed.**



Danger!
Immediate danger to life and limb!



Caution!
Potential threat to the product and its environment.



Note:
Useful information and special features.

2 Safety notes

Please observe the following safety notes when assembling and operating the unit:

- Assembly, installation and servicing may only be performed by properly trained specialists
- Do not obstruct the air inlet and outlet of the fan-and-filter unit inside and outside the enclosure (see also section “4.2.2 Layout of the components in the enclosure”, page 7)
- The heat loss of the components installed in the enclosure must not exceed the specific air throughput of the fan-and-filter unit
- The louvres must always have their opening pointing downwards
- Use only original spare parts and accessories
- Do not make any changes to the fan-and-filter unit other than those described in these and other applicable instructions
- The fan-and-filter unit must only be connected to the mains with the system de-energised. Connect the pre-fuse specified on the rating plate
- Changes to the direction of airflow must only be carried out with the system de-energised
- Changes to the positioning of the mains connection must only be carried out with the system de-energised
- Never insert your fingers into the rotating fan blade
- Electrical connection and any repairs may only be carried out by authorised specialist personnel

3 Device description

Depending on the model chosen, your fan-and-filter unit may vary in appearance from the illustrations contained in these instructions. However, the functions are identical in principle.

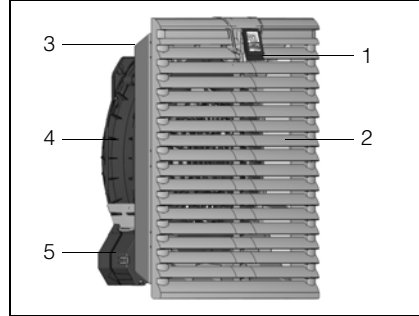

Fig. 1: Device description

Key

- 1 Function logo
(to release the louvred grille)
- 2 Louvred grille
- 3 Filter box with filter mat
- 4 Fan housing
- 5 Variable electrical connection

3.1 Functional description

The fan-and-filter unit in conjunction with the corresponding outlet filter(s) is used to dissipate heat loss from enclosures, ventilate the enclosure and protect temperature-sensitive components. This is achieved via the direct infeed of ambient air, the temperature of which must be less than the admissible enclosure interior temperature. The system is fitted into prepared cut-outs.

3.1.1 Main components

The fan-and-filter unit is comprised of the following four main components: Fan motor, filter box, louvred grille with function logo and filter medium.

3 Device description

EN

3.1.2 Control

Rittal fan-and-filter units may be controlled more efficiently using a thermostat (Model No. 3110.000), digital temperature display (Model No. 3114.200), temperature-dependent speed control (Model No. 3120.200, 3235.440, 3235.450) and/or hygrostat (Model No. 3118.000).



Note:

The control unit 3120.200 can only be used with single-phase AC units. The control units 3235.440 and 3235.450 can only be used with fan-and-filter units with integrated control interface (EC fan-and-filter units and fan-and-filter units with EMC shielding from an air throughput of 180 m³/h. Model No. 3240.500/600, 3241.500/600, 3243.500/600, 3244.500/600, 3245.500/600.

3.1.3 Safety equipment

The fan is equipped with thermal winding protection devices for protection against excess current and, in some cases, against overtemperature. For rotary current fans, the winding protection is located in the star earthing of the motor.

3.1.4 Filter mats

The fan-and-filter unit/outlet filter is supplied with a standard filter mat already installed. The filter must be checked regularly in accordance with the level of dust exposure and replaced as necessary.

In order to increase the protection category, and in the case of dust with a grain size of < 10 µm, we recommend the use of fine filter mats.



Note:

The air throughput volume will be reduced. Special filter mats are required for EMC fan-and-filter units (see accessories).

3.2 Proper use

Rittal fan-and-filter units were developed and designed in accordance with the state of the art and the recognised rules governing technical safety. Nevertheless, if used improperly, they may pose a threat to life and limb or cause damage to property. The unit is only intended for ventilating enclosures and electronic cases. Any other use is deemed improper. The manufacturer will not be liable for any damages caused as a result of improper use, or for incorrect assembly, installation and use. All risk is borne solely by the user. Proper usage also includes the observation of all valid documents and compliance with the inspection and servicing conditions.

3.3 Scope of supply

The fan is supplied in a packaging unit in a fully assembled state and ready to connect. Please check the scope of supply for completeness.

| Qty. | Description |
|------|---|
| 1 | Fan-and-filter unit |
| 4 | – Mounting screws (not for 3237.1xx to 3239.1xx) |
| 1 | – Assembly, installation and operating instructions |
| 1 | Drilling template, self-adhesive |
| 1 | Standard or EMC filter mat |

Tab. 1: Scope of supply

4 Assembly and connection

4.1 Choosing the installation site

When choosing the installation site for the enclosure, please observe the following:

- The site for the enclosure, and hence the arrangement of the fan-and-filter unit, must be carefully selected so as to ensure good ventilation
- The site must be free from excessive dirt and moisture
- Fan-and-filter units must always be installed on vertical panels (door or walls)
- The ambient temperature must be lower than the permissible enclosure interior temperature
- The mains connection data as stated on the rating plate of the unit must be guaranteed

4.2 Assembly instructions

4.2.1 General

- Check the packaging carefully for signs of damage. Any packaging damage may be the cause of a subsequent functional failure
- The fan-and-filter and outlet filter must always be mounted on an enclosure in order to ensure air exchange

**Note:**

The outlet filter should be at least the same size as the fan-and-filter unit.

- The enclosure must be sealed on all sides (IP 54). If the enclosure has a leak, unfiltered, contaminated air may enter the enclosure, depending on the direction of airflow of the fan
- If two or more fan-and-filter units are arranged one above the other, a minimum spacing of 15 mm should be observed (between drilling templates). Only then is it guaranteed that the louvred grille can be opened without restriction.

4.2.2 Layout of the components in the enclosure

Observe the air flows from the internal fans of installed electronic components. For installation, it is important to ensure that the airflows of fans and built-in electronic components do not have a negative influence on one another (air short-circuit). The corresponding minimum distances between the fan and component must be observed in order to ensure unhindered air circulation.

4.3 Fitting the fan-and-filter unit or outlet filter

The fan-and-filter unit or outlet filter is mounted on a vertical panel of the enclosure:

- For this purpose, the appropriate door, side or rear panel must be cut out using the supplied drilling template.

The fan-and-filter unit is generally fitted in the lower part of the enclosure, and the outlet filter in the upper part.

4.3.1 Cutting out the enclosure

- Stick the self-adhesive drilling template supplied to the envisaged position on the door, side or rear panel of the enclosure.

Lines indicating the dimensions of cut-outs and drilling specifications for mounting and fixing of the fan (only necessary for sheet metal thickness 2.5 mm and above) are to be found on the drilling template. See also fig. 8 and fig. 9 on page 16.

**Risk of injury!**

Carefully deburr all cut-outs to prevent injuries caused by sharp edges.

- Make the cut-outs including the line width as per the drilling template. Deburr the cut-outs.

4 Assembly and connection

EN

4.3.2 Fitting the fan-and-filter unit

- The fan may be fitted without tools, by simply snapping into the preconfigured mounting cut-out
- Make sure that the clips have snapped into place properly to guarantee secure mounting
- From a sheet metal thickness of 2 mm, the clips should be pressed in individually
- From a sheet metal thickness of 2.5 mm, the fan-and-filter unit must be screw-fastened in addition
- To drill the lower holes, it is necessary to remove the louvred grille as shown in fig. 2

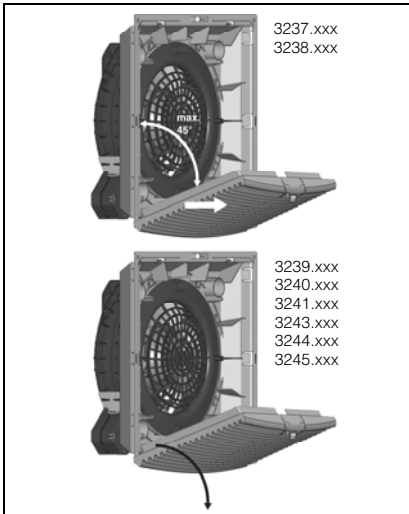

Fig. 2: Release the louvred grille

- If transporting, it is necessary that you screw-fasten the fan to prevent it from falling out of the mounting cut-out.
- The fan-and-filter unit is a rotating component that may transfer vibrations and oscillations. Appropriate measures to decouple vibration must be taken in advance by the company responsible for the overall plant or system.

- The protection category can be increased by means of the following accessories:
 - IP 55 by using an additional fine filter mat or hose-proof hood
 - IP 56 by using a hose-proof hood



Note:

To increase the protection category, an additional fine filter mat or hose-proof hood must be used in both the fan-and-filter unit and the outlet filter.

4.4 Notes on electrical connection

When performing the electrical connection, it is important to observe all valid national and regional regulations as well as the provisions of the responsible power supply company. Electrical connection must only be carried out by a qualified electrician who is responsible for compliance with the existing standards and regulations.

4.4.1 Connection data

- The voltage and frequency of the connection must correspond to the values stated on the rating plate
- Electrical connection and any repairs may only be carried out by authorised specialist personnel
Use only original spare parts!
- For 1~ and 24 V (DC) fans, install the pre-fuse prescribed on the rating plate (circuit-breaker or slow fuse) to protect against short-circuiting
- With the rotary current variant, install the pre-fuse prescribed on the rating plate or a circuit-breaker/back-up protection to protect against short-circuiting, and set it to the prescribed rating value
- The direction of airflow and the direction of rotation are each marked on the motor housing with an arrow
- If a phase is missing, the fan will not start. If the rotary field is incorrect, the fan will run backwards

4.4.2 Overvoltage protection and supply line load

The unit does not have its own overvoltage protection. Measures must be taken by the operator at the supply end to ensure effective lightning and overvoltage protection. The mains voltage must not exceed a tolerance of $\pm 10\%$.

4.4.3 PE conductor connection

The PE conductor connection must be connected to the PE conductor system of the overall system.

5 Carrying out the electrical connection

5.1 Connecting the power supply

- Complete the electrical connection by following the wiring plans.

**Note:**

For technical data, refer to the rating plate.

- Remove the red cover from the electrical connection.

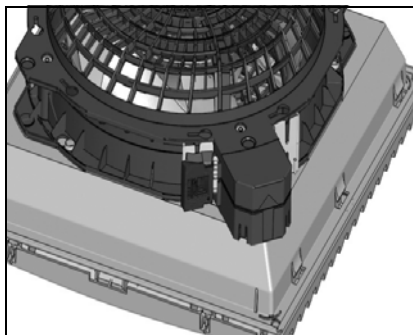

Fig. 3: Access the electrical connection

- Insert the connection cable with wire end ferrules into the screwless spring terminals. Choose an appropriate pre-fuse according to the line cross-section (2 x 0.75 – 2.5 mm² multi-wire, 2 x 1.5 – 2.5 mm² fine-wire soldered).

**Caution!**

If no wire end ferrules are used, the insulation of the individual wires should be stripped to a max. of 9 mm (to comply with clearance and creepage distances).

- Re-attach the electrical connection cover.

**Note:**

Fan-and-filter unit 3237.xxx is connected by way of two single wires which are led out of the unit.

5.2 Rotating the voltage connection

If the position of the voltage connection is not ideally accessible, it may be rotated through 90° and snapped into position. To this end, press down on the release button of the bayonet connection at the rear of the fan. Units 3238.xxx to 3239.xxx are released by pulling out the clip (see fig. 4) of the bayonet connection.

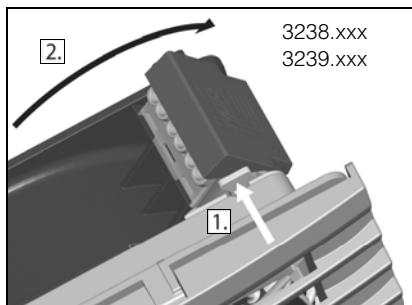

Fig. 4: Release the bayonet connection

Units 3240.xxx, 3241.xxx, 3243.xxx to 3245.xxx are released by pressing the release button of the bayonet connection (see fig. 5), located on the opposite corner from the connection terminal.

6 Commissioning

EN

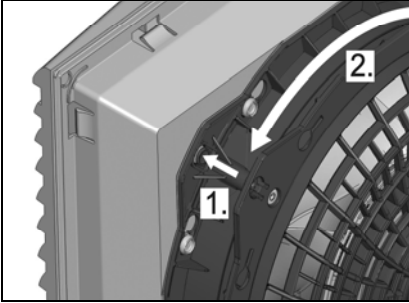

Fig. 5: Release the bayonet connection

5.3 Changing the direction of airflow

The direction of airflow blows into the enclosure from the outside as standard. Should it become necessary to change the direction of airflow for technical reasons (space, specific component air routing etc.), this is easily achieved. Simply release the fan housing and rotate it through 180°. To release, please follow the same procedure as described under “5.2 Rotating the voltage connection”, page 9.

Please also observe the instructions outlined under “4.2.1 General”, page 7.

6 Commissioning

The fan-and-filter unit operates automatically, in other words, the fan will start up once the power has been switched on. Depending on the model, the following voltage variants are supported:

- 24 V DC
- 115 V, 1~
- 230 V, 1~
- 400/460 V, 3-phase

7 Installing and changing the filter

The fan-and-filter unit and outlet filter are supplied as standard with a standard filter mat for the pre-filtering of dry, coarse dust and lint. In order to increase the protection category, and in the case of dust with a grain size of $< 10 \mu\text{m}$, we recommend the use of fine filter mats (optionally available). The filter should be checked at regular intervals in accordance with the level of dust exposure (recommended: at the latest after 2,000 operating hours) and replaced as necessary.



Note:

Use only original Rittal filters which bear the Rittal logo in order to safeguard the designated protection category, air throughput and operating approvals.



Risk of injury!

Only change the filter mat while the fan rotor is stationary.

Never insert your fingers into the fan rotor.

To insert or replace the filter, proceed as follows (direction of airflow: drawing from outside and blowing into the enclosure):

- First press the catch of the louvred grille (Rittal logo) up slightly with one finger (see fig. 6)
- Once it is released, the louvred grille can be dropped open by approx. 70° or 90°
- If necessary, first place the fine filter mat into the housing
- Ensure that the open (roughened) side faces towards the louvred grille
- Then insert the enclosed standard filter mat
- Here again, ensure that the open side (without Rittal logo) faces towards the louvred grille (see fig. 7)
- Now push the louvred grille back onto the enclosure until it snaps audibly into position.

8 Inspection and maintenance

EN

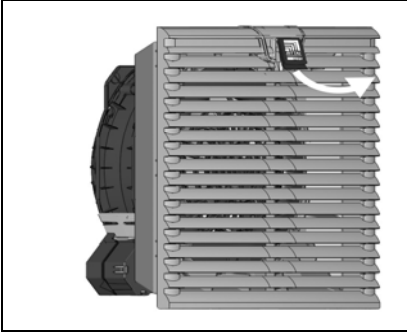

Fig. 6: Release the louvred grille

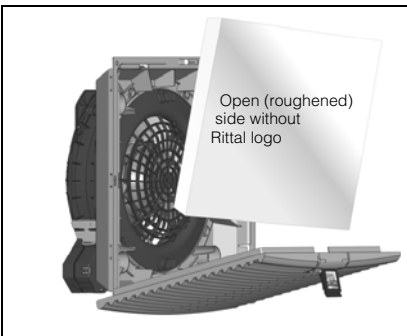

Fig. 7: Installing the standard filter mat



Note:

If it becomes necessary to change the direction of the airflow (see 5.3 “Changing the direction of airflow”, page 10), the installation is reversed accordingly.

8 Inspection and maintenance



Risk of electric shock!
The unit is live.
Switch off the power supply before opening, and take suitable precautions against it being accidentally switched back on.

The built-in, maintenance-free fan is mounted on a friction bearing (3237.xxx, 3238.xxx and 3239.xxx) or ball bearing (3240.xxx, 3241.xxx, 3243.xxx to 3245.xxx), and is protected against humidity and dust, and equipped with a temperature monitor. The life expectancy is at least 40,000 operating hours (L10, 40°C). The fan-and-filter unit is thus largely maintenance free.

From time to time, the components may need to be cleaned using a vacuum cleaner or compressed air if they become visibly dirty.

Any stubborn, oily stains may be removed using a non-flammable detergent, such as degreaser.



Caution!

Risk of fire!

Never use flammable liquids for cleaning.

Sequence of maintenance measures:

- Check the level of dirt.
- Filter soiling?
Replace the filter.
- Fan membranes soiled?
Clean.
- Check the noise generation of the fan.
- Compressed air cleaning

9 Storage and disposal



Caution!

Risk of damage!

The fan unit must not be stored at temperatures above +70°C or below -30°C.

Disposal can be performed at the Rittal plant.

Please contact us for advice.

10 Technical specifications

EN

10 Technical specifications

- Observe the mains connection data (voltage and frequency) as per the rating plate
- Observe the pre-fuse as per the specifications on the rating plate

| | Unit | Model No. | | | | | |
|---|---------|--|-------------------|-----------------|--|-------------------|--------------------|
| Fan-and-filter unit, RAL 7035 | – | 3237.100 | 3237.110 | 3237.124 | 3238.100 | 3238.110 | 3238.124 |
| EMC fan-and-filter unit, RAL 7035 | – | 3237.600 | – | – | 3238.600 | – | – |
| Rated operating voltage | V Hz | 230, 1~, 50/60 | 115, 1~, 50/60 | 24 (DC) | 230, 1~, 50/60 | 115, 1~, 50/60 | 24 (DC) |
| Rated current max. | A | 0.065/0.052 | 0.12/0.1 | 0.125 | 0.12/0.11 | 0.24/0.22 | 0.24 |
| Power consumption | W | 11/9 | | 3 | 19/18 | | 5.5 |
| Pre-fuse T | A | 2 | | | | | |
| Dimensions | | | | | | | |
| Width (B1) x height (H1) | mm | 116.5 x 116.5 | | | 148.5 x 148.5 | | |
| Required mounting cut-out (B2 x H2) | mm | 92 x 92 | | | 124 x 124 | | |
| Depth (T1) | mm | 16 | | | | | |
| Max. installation depth (T2) | mm | 43 | | | 58.5 | | |
| Air throughput, unimpeded airflow | m³/h | 20/25 | | 20 | 55/66 | | 55 |
| Air throughput with outlet filter including standard filter mat | m³/h | 1 x 3237.200: 15/18 | | | 1 x 3238.200: 43/50 | | |
| | | – | | | 2 x 3238.200: 46/56 | | |
| Outlet filter | – | 3237.200 | | | 3238.200 | | |
| EMC outlet filter | – | 3237.060 | | | 3238.060 | | |
| Fan | – | Axial, self-starting shaded pole motor | | Axial, DC motor | Diagonal, self-starting shaded pole motor | | Diagonal, DC motor |
| Noise pressure level | dB (A) | 38/43 | | 38 | 46/49 | | 46 |
| Operating temperature | °C | -15...+55 | | | | | |
| Storage temperature | °C | -30...+70 | | | | | |
| Protection category (to IEC 60 529) | – | IP 54 standard IP 55 with hose-proof hood IP 56 with hose-proof hood | | | IP 54 standard IP 55 with hose-proof hood IP 56 with hose-proof hood | | |

Tab. 2: Technical specifications

Technical modifications reserved.

10 Technical specifications

EN

| | Unit | Model No. | | |
|---|---------|--|-------------------|--------------------|
| Fan-and-filter unit, RAL 7035 | – | 3239.100 | 3239.110 | 3239.124 |
| EMC fan-and-filter unit, RAL 7035 | – | 3239.600 | – | – |
| Rated operating voltage | V Hz | 230, 1~, 50/60 | 115, 1~, 50/60 | 24 (DC) |
| Rated current max. | A | 0.12/0.11 | 0.24/0.22 | 0.23 |
| Power consumption | W | 19/18 | | 5.5 |
| Pre-fuse T | A | 2 | | |
| Dimensions | | | | |
| Width (B1) x height (H1) | mm | 204 x 204 | | |
| Required mounting cut-out (B2 x H2) | mm | 177 x 177 | | |
| Depth (T1) | mm | 24 | | |
| Max. installation depth (T2) | mm | 90 | | |
| Air throughput, unimpeded airflow | m³/h | 105/120 | | 105 |
| Air throughput with outlet filter including standard filter mat | m³/h | 1 x 3239.200: 87/100 | | |
| | | 2 x 3239.200: 93/108 | | |
| | | 1 x 3240.200: 98/111 | | |
| Outlet filter | – | 3239.200 | | |
| EMC outlet filter | – | 3239.060 | | |
| Fan | – | Diagonal, self-starting shaded pole motor | | Diagonal, DC motor |
| Noise pressure level | dB (A) | 46/49 | | 46 |
| Operating temperature | °C | -15...+55 | | |
| Storage temperature | °C | -30...+70 | | |
| Protection category (to IEC 60 529) | – | IP 54 standard IP 55 with additional fine filter mat or hose-proof hood IP 56 with hose-proof hood | | |

Tab. 3: Technical specifications

Technical modifications reserved.

10 Technical specifications

EN

| | Unit | Model No. | | | | | |
|---|---------|--|-------------------|--------------------|---|-------------------|--------------------|
| Fan-and-filter unit, RAL 7035 | - | 3240.100 | 3240.110 | 3240.124 | 3241.100 | 3241.110 | 3241.124 |
| EMC fan-and-filter unit, RAL 7035 | - | 3240.600 | - | - | 3241.600 | - | - |
| Rated operating voltage | V Hz | 230, 1~, 50/60 | 115, 1~, 50/60 | 24 (DC) | 230, 1~, 50/60 | 115, 1~, 50/60 | 24 (DC) |
| Rated current max. | A | 0.21/0.19 | 0.42/0.38 | 0.43 | 0.26/0.24 | 0.52/0.48 | 0.8 |
| Power consumption | W | 35/34 | | 10 | 40/42 | 40/42 | 19 |
| Pre-fuse T | A | 2 | 4 | 2 | 4 | | 2 |
| Dimensions | | | | | | | |
| Width (B1) x height (H1) | mm | 255 x 255 | | | | | |
| Required mounting cut-out (B2 x H2) | mm | 224 x 224 | | | | | |
| Depth (T1) | mm | 25 | | | | | |
| Max. installation depth (T2) | mm | 107 | | | | | |
| Air throughput, unimpeded airflow | m³/h | 180/160 | | 180 | 230/250 | | 230 |
| Air throughput with outlet filter including standard filter mat | m³/h | 1 x 3240.200: 138/121 | | | 1 x 3240.200: 183/205 | | |
| | | 2 x 3240.200: 165/140 | | | 2 x 3240.200: 203/230 | | |
| | | 1 x 3243.200: 165/140 | | | 1 x 3243.200: 203/230 | | |
| Outlet filter | - | 3240.200 | | | | | |
| EMC outlet filter | - | 3240.060 | | | | | |
| Fan | - | Diagonal, self-starting shaded pole motor | | Diagonal, DC motor | Diagonal, self-starting shaded pole motor | | Diagonal, DC motor |
| Noise pressure level | dB (A) | 51/46 | | 51 | 54/56 | | 54 |
| Operating temperature | °C | -30...+55 | | | | | |
| Storage temperature | °C | -30...+70 | | | | | |
| Protection category (to IEC 60 529) | - | IP 54 standard IP 55 with additional fine filter mat or hose-proof hood IP 56 with hose-proof hood | | | | | |

Tab. 4: Technical specifications

Technical modifications reserved.

10 Technical specifications

EN

| | Unit | Model No. | | | | | | | |
|---|--------|--|-----------------|--|-----------------|--------------------------------|---|---------------------|--|
| Fan-and-filter unit, RAL 7035 | – | 3243.100 | 3243.110 | 3244.100 | 3244.110 | 3244.140 | 3245.500 | 3245.510 | |
| EMC fan-and-filter unit, RAL 7035 | – | 3243.600 | – | 3244.600 | – | – | 3245.600 | – | |
| Rated operating voltage | V Hz | 230, 1~, 50/60 | 115, 1~, 50/60 | 230, 1~, 50/60 | 115, 1~, 50/60 | 400/460, 3~, 50/60 | 200...240 1~, 50/60 | 100...130 1~, 50/60 | |
| Rated current max. | A | 0.37/0.39 | 0.78/0.8 | 0.43/0.6 | 0.9/1.25 | 0.17/0.21 | 1.33 | 2.1 | |
| Power consumption | W | 70/87 | 75/90 | 95/135 | 100/145 | 93/140 | 165 | 165 | |
| Pre-fuse T | A | 4 | 6 | 4 | 6 | Motor circuit-breaker | 4 | 6 | |
| Dimensions | | | | | | | | | |
| Width (B1) x height (H1) | mm | 323 x 323 | | | | | | | |
| Required mounting cut-out (B2 x H2) | mm | 292 x 292 | | | | | | | |
| Depth (T1) | mm | 25 | | | | | | | |
| Max. installation depth (T2) | mm | 118.5 | | 130.5 | | | 130.5 | | |
| Air throughput, unimpeded airflow | m³/h | 550/600 | | 700/770 | | | 900 | | |
| Air throughput with outlet filter including standard filter mat | m³/h | 1 x 3243.200: 465/510 2 x 3243.200: 508/548 | | 1 x 3243.200: 544/587 2 x 3243.200: 614/662 | | | 1 x 3243.200: 680 2 x 3243.200: 820 | | |
| Outlet filter | – | 3243.200 | | | | | | | |
| EMC outlet filter | – | 3243.060 | | | | | | | |
| Fan | – | Diagonal, capacitor motor | | | | Diagonal, rotary current motor | Diagonal, EC motor | | |
| Noise pressure level | dB (A) | 59/61 | | 65/66 | | 67/70 | 72 | | |
| Operating temperature | °C | -30...+55 | | | | | | | |
| Storage temperature | °C | -30...+70 | | | | | | | |
| Protection category (to IEC 60 529) | – | IP 54 standard IP 55 with additional fine filter mat or hose-proof hood IP 56 with hose-proof hood | | | | | IP 51 standard IP 52 with additional fine filter mat IP 56 with hose-proof hood | | |

Tab. 5: Technical specifications

Technical modifications reserved.

11 Cut-out/drilling dimensions

EN

11 Cut-out/drilling dimensions

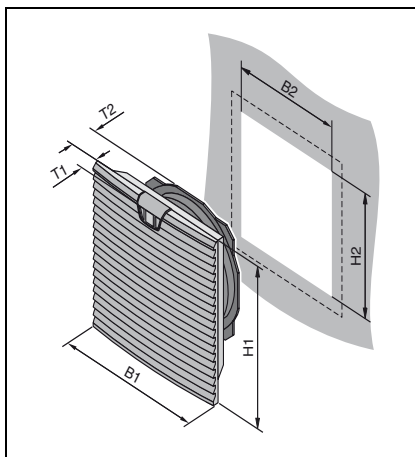

Fig. 8: Cut-out dimensions

B = Width, T = Depth

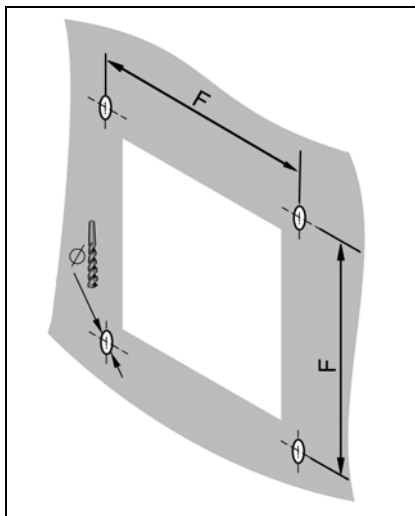

Fig. 9: Drilling pattern



Note:

From a certain wall thickness, a slightly larger cut-out is required (see the enclosed drilling template).

| Model No. | B2 x H2 mm | T2 mm |
|-----------------|------------|-------|
| 3237.xxx | 92 x 92 | 43 |
| 3238.xxx | 124 x 124 | 58.5 |
| 3239.xxx | 177 x 177 | 90 |
| 3240.xxx | 224 x 224 | 107 |
| 3241.xxx | 224 x 224 | 107 |
| 3243.xxx | 292 x 292 | 118.5 |
| 3244.xxx | 292 x 292 | 130.5 |
| 3245.xxx | 292 x 292 | 130.5 |

Tab. 6: Cut-out dimensions

| Model No. | Ø mm | F mm |
|-----------------|------|-------|
| 3237.xxx | 3.5 | 100.5 |
| 3238.xxx | 3.5 | 132.5 |
| 3239.xxx | 4.5 | 185 |
| 3240.xxx | 4.5 | 234 |
| 3241.xxx | 4.5 | 234 |
| 3243.xxx | 4.5 | 302 |
| 3244.xxx | 4.5 | 302 |
| 3245.xxx | 4.5 | 302 |

Tab. 7: Drilling dimensions

12 EMC fan/outlet filter

EN

12 EMC fan/outlet filter

To achieve EMC protection, the EMC fans and EMC outlet filters should be snapped into the mounting cut-out and screw-fastened using the screws supplied. Next, the four contact foils should be stuck on all-round between the fan-and-filter unit and the inside of the enclosure as shown in the following illustration.

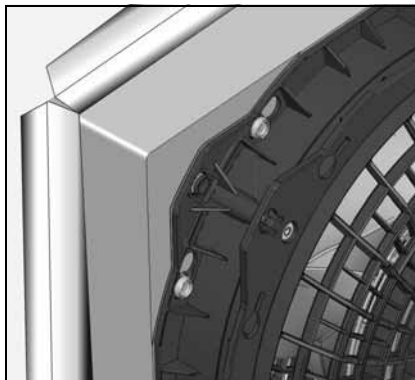

Fig. 10: EMC contact foils



Note:

EMC protection can only be guaranteed when using original Rittal EMC filter media (Model Nos. 3237.066, 3238.066, 3239.066, 3240.066, 3243.066).

13 Connection diagrams

EN

13 Connection diagrams

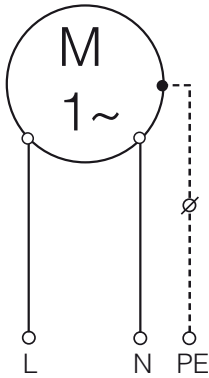

3237.100/.110/.600
3238.100/.110/.600
3239.100/.110/.600

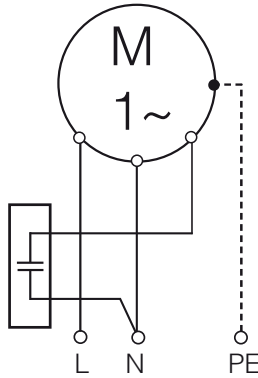

3243.100/.110/.600
3244.100/.110/.600

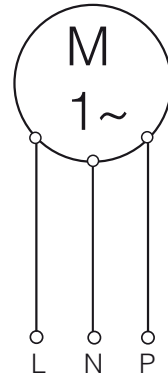

3245.500/.510/.600
Details,
see page 19

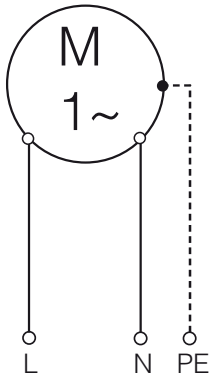

3240.100/.110/.600
3241.100/.110/.600

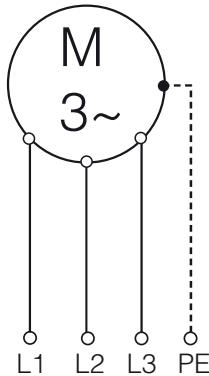

3244.140

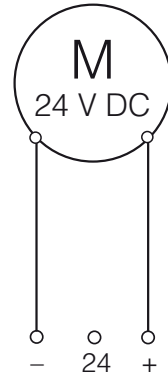

3237.124
3238.124
3239.124
3240.124
3241.124

Fig. 11: Connection diagrams

13 Connection diagrams

EN

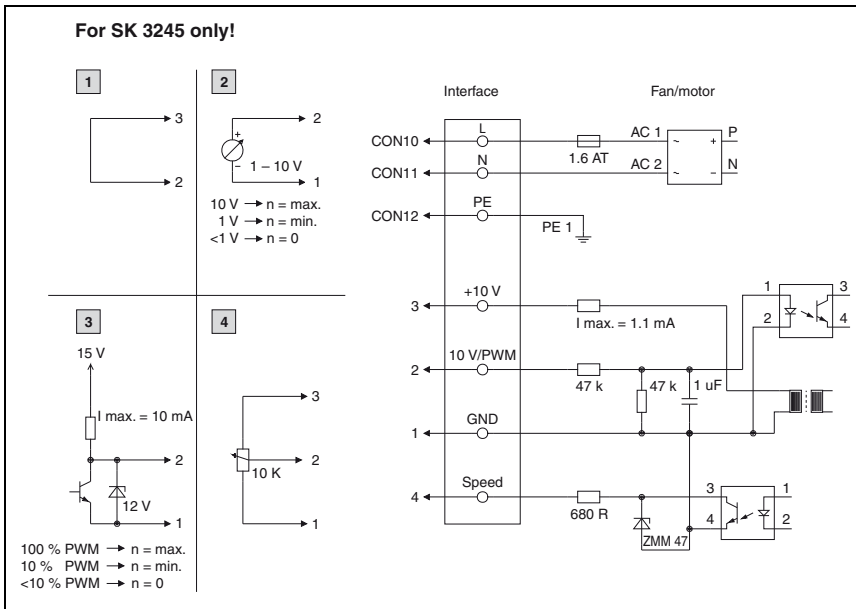

Fig. 12: Connection diagram 3245

- 1** Max. speed (as delivered)
- 2** Adjustable speed
- 3** Adjustable speed via PWM 1 – 10 kHz
- 4** Adjustable speed via potentiometer

| No. | Connection | Function/Assignment |
|-------|--------------|---|
| CON10 | L | Power supply 200...240 V AC, 50...60 Hz |
| CON11 | N | Neutral conductor |
| CON12 | PE | PE conductor |
| 1 | GND | GND connection of the control interface |
| 2 | 0...10 V/PWM | Control input 0...10 V or PWM, galvanically isolated, impedance 100 kΩ |
| 3 | +10 V | Voltage output 10 V max. 1.1 mA, galvanically isolated, not short circuit-protected |
| 4 | Speed | Speed output Open Collector, 1 pulse per revolution, galvanically isolated |

Tab. 8: Explanations to fig. 12

14 EC declaration of conformity

EN

14 EC declaration of conformity

EG-Konformitätserklärung
Maschinenrichtlinie 2006/42/EG Anhang II A
EC Declaration of Conformity
Machinery Directive 2006/42/EC Annex II A

Hiermit erklären wir, *(We hereby declare)*

Rittal GmbH & Co. KG, Auf dem Stützelberg, D-35745 Herborn

dass die Filterlüfter: *(that the fan-and-filter units:)*

SK 3237.xxx SK 3238.xxx SK 3239.xxx SK 3240.xxx SK 3241.xxx SK 3243.xxx SK 3244.xxx

„xxx“ steht für *(“xxx” applies to):*

100, 109, 110, 124^{a)}, 140, 600, 609, 610

^{a)} 24 VDC Version; nicht nach NSpRI 2006/95/EG *(does not comply with LVD 2006/95/EC)*

folgenden Richtlinien entsprechen: *(comply with the following directives:)*

Maschinenrichtlinie 2006/42/EG *(Machinery directive 2006/42/EC)*

Elektromagnetische Verträglichkeit 2004/108/EG *(Electromagnetic compatibility 2004/108/EC)*

Bei einer nicht mit uns abgestimmten Änderung der Maschine verliert diese EG-Konformitätserklärung ihre Gültigkeit.

This declaration of EC conformity shall become null and void when the assembly is subjected to any modification that has not met with our approval.

Herborn, 29.9.2010

Verantwortlich für Dokumentation
(Responsible for documentation)

Rittal GmbH & Co. KG
Auf dem Stützelberg
D-35745 Herborn

Dr. M. Lang
Leitung Qualitätsmanagement
(Vice President Quality Management)

Mehr Informationen finden Sie auf www.rittal.de
Please find further information at www.rittal.com

Rittal – The System.

Faster – better – everywhere.

- Enclosures
- Power Distribution
- Climate Control
- IT Infrastructure
- Software & Services

RITTAL GmbH & Co. KG
Postfach 1662 • D-35726 Herborn
Phone +49(0)2772 505-0 • Fax +49(0)2772 505-2319
E-mail: info@rittal.de • www.rittal.com

ENCLOSURES

POWER DISTRIBUTION

CLIMATE CONTROL

IT INFRASTRUCTURE

SOFTWARE & SERVICES



FRIEDHELM LOH GROUP