

# Licross

## Trunking Sensor PS2 DALI2

56TL1MDSPS2A

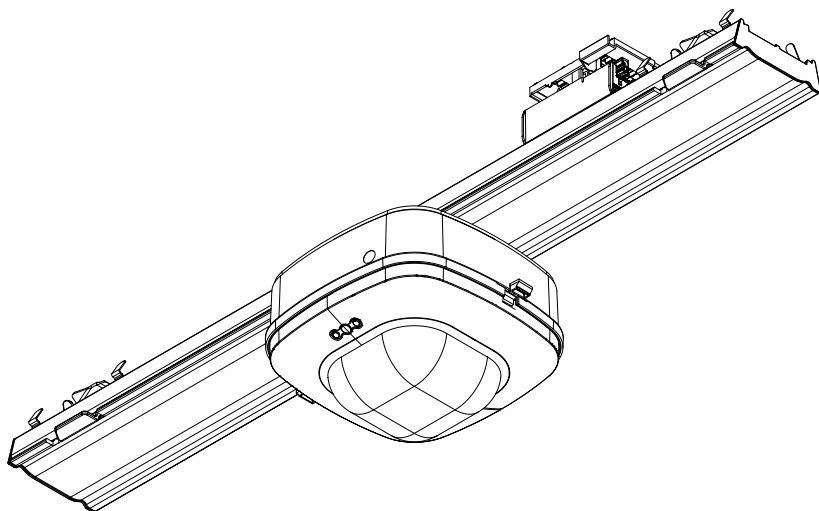

**siteco**

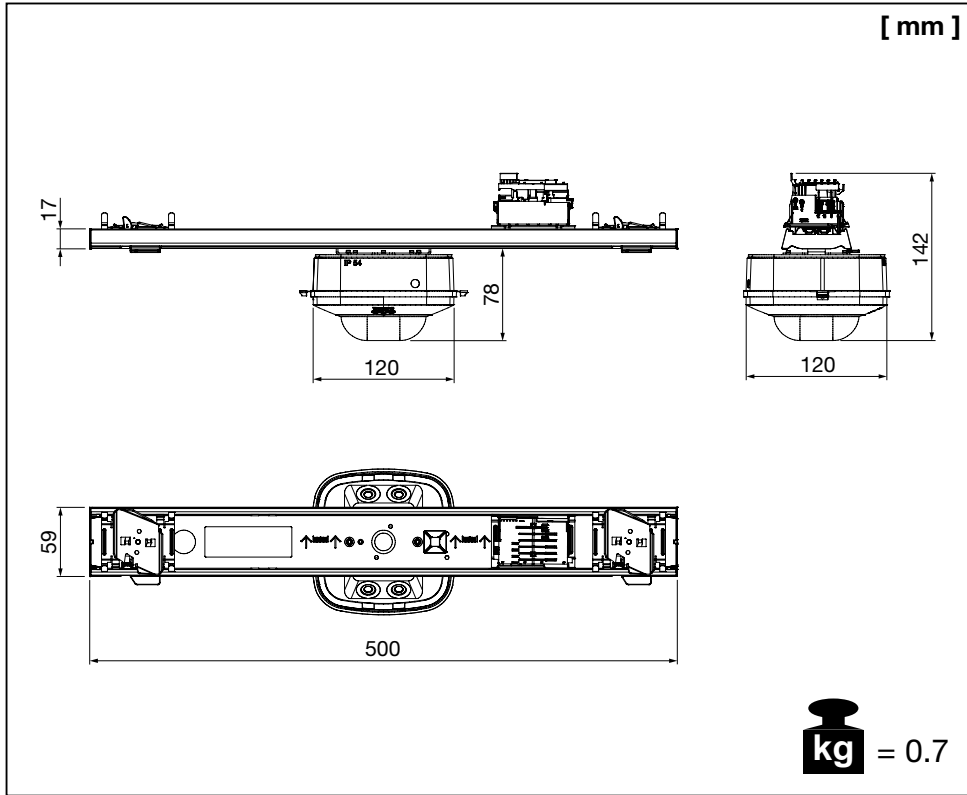

=

	L1 (1)	L2 (2)	L3 (3)	L' (4)	L'' (5)	R (6)	PE (7)
D2+ (8)	D1+ (9)	D2- (10)	D1- (11)	N (12)	N' (13)	N'' (14)	

Die individuelle Auslegung der Elektroinstallation muss gemäß den Installationsrichtlinien IEC 60364 / DIN VDE 0100 erfolgen. Zudem sind die Einschaltströme, die Abschaltbedingungen für Schutzrichtungen (Schleifenimpedanz) und die Einhaltung des max. zulässigen Spannungsfalls zu beachten.  
 The individual design of the electrical installation must be realized in accordance with the installation guidelines IEC 60364 / DIN VDE 100. In addition, the switch-on currents, the switch-off conditions for protective devices (loop impedance) and compliance with the maximum permissible voltage drop must be observed.

**1** Umgebungstemperatur während der Installation: +5°C...+40°C  
 Ambient temperature during installation:

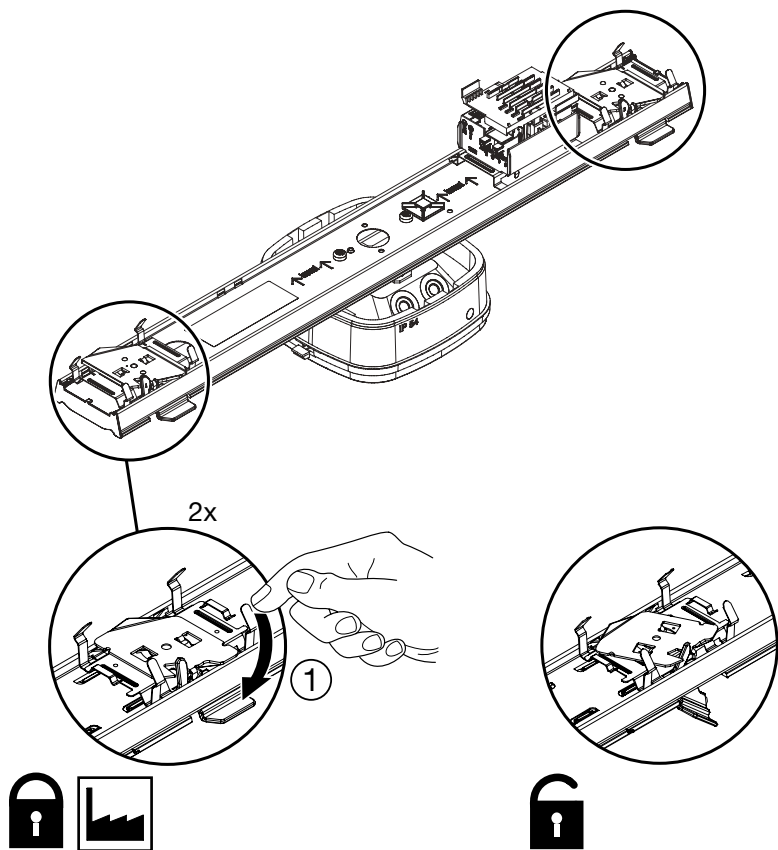

**2**

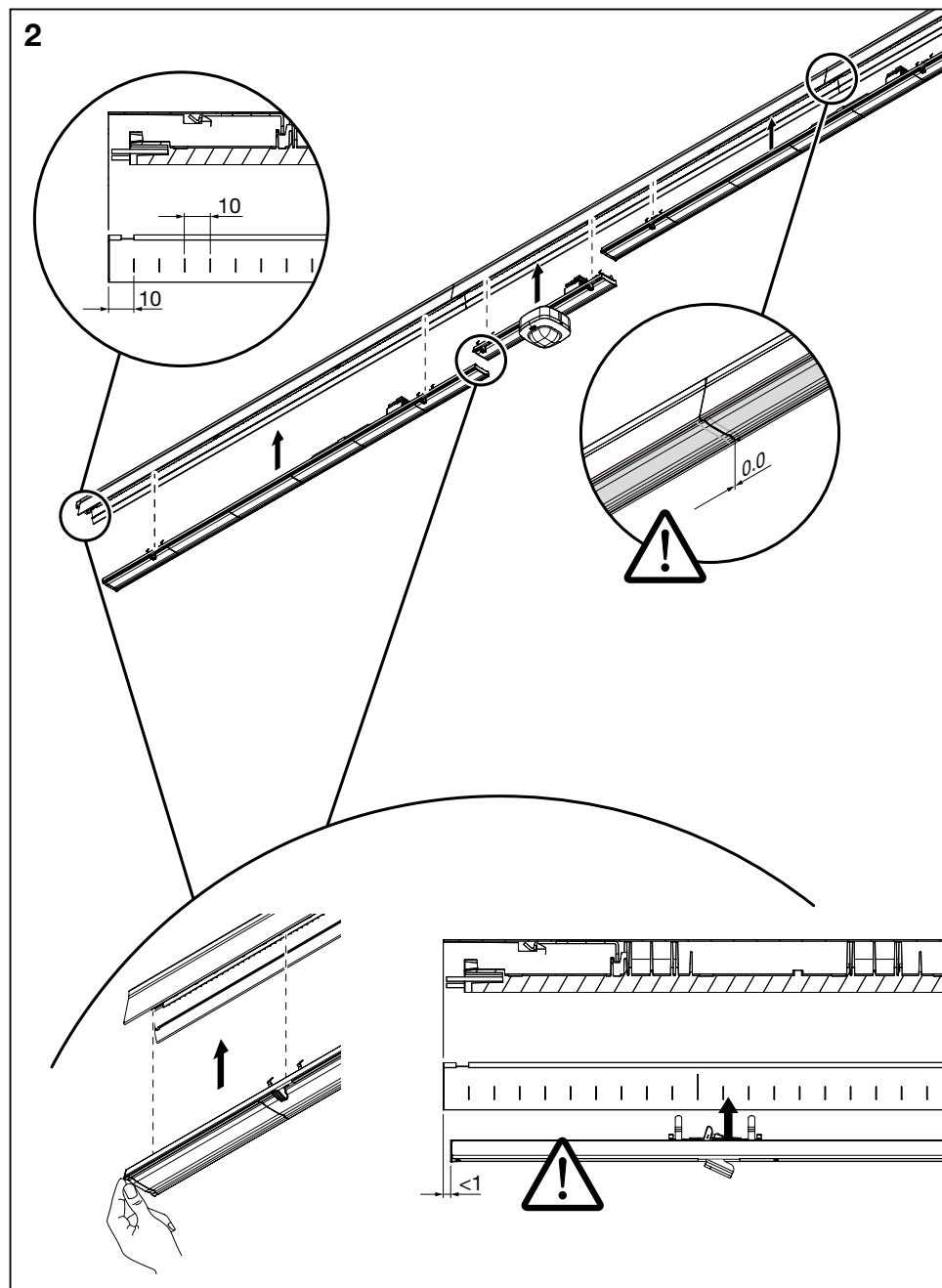

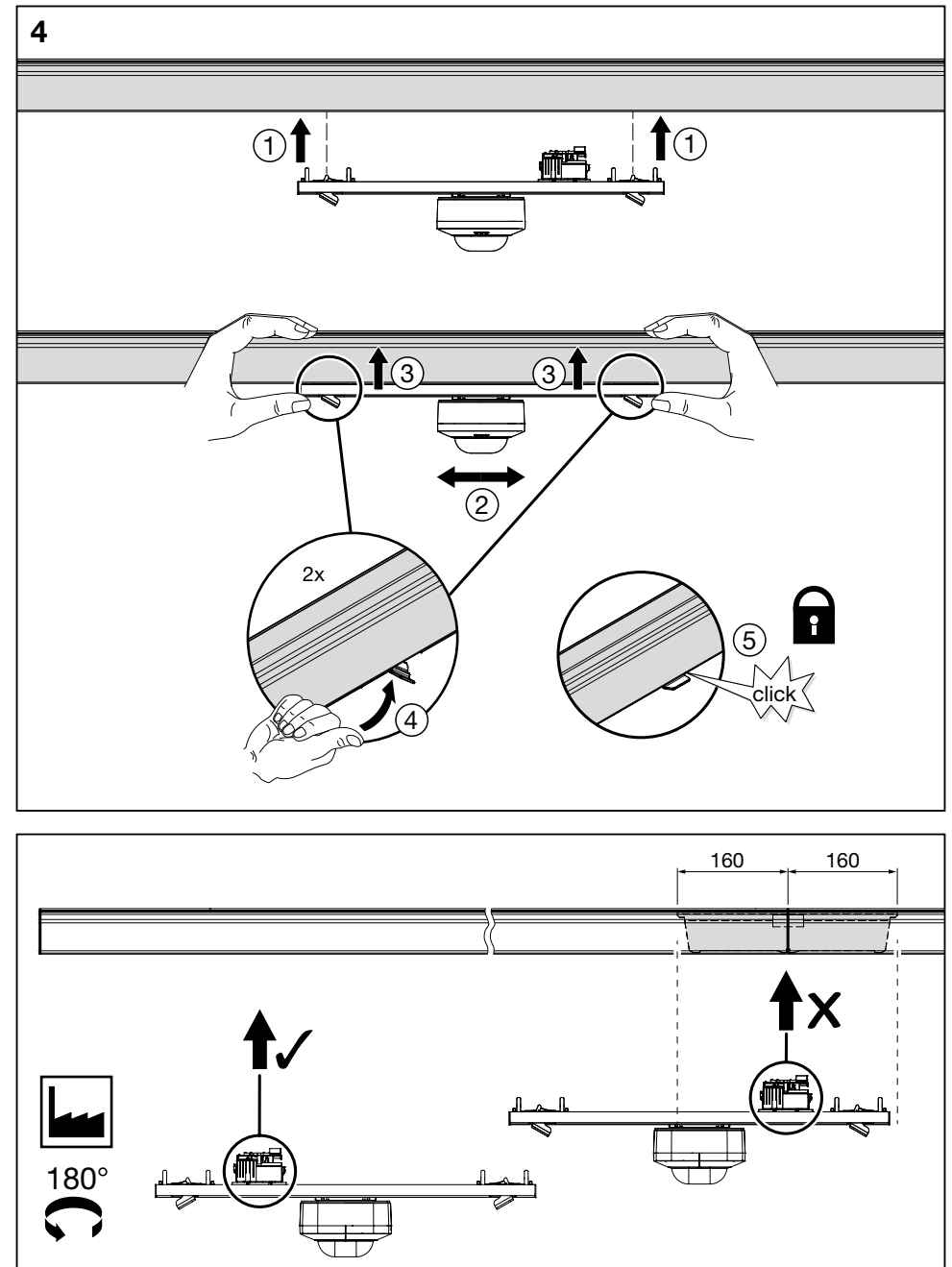
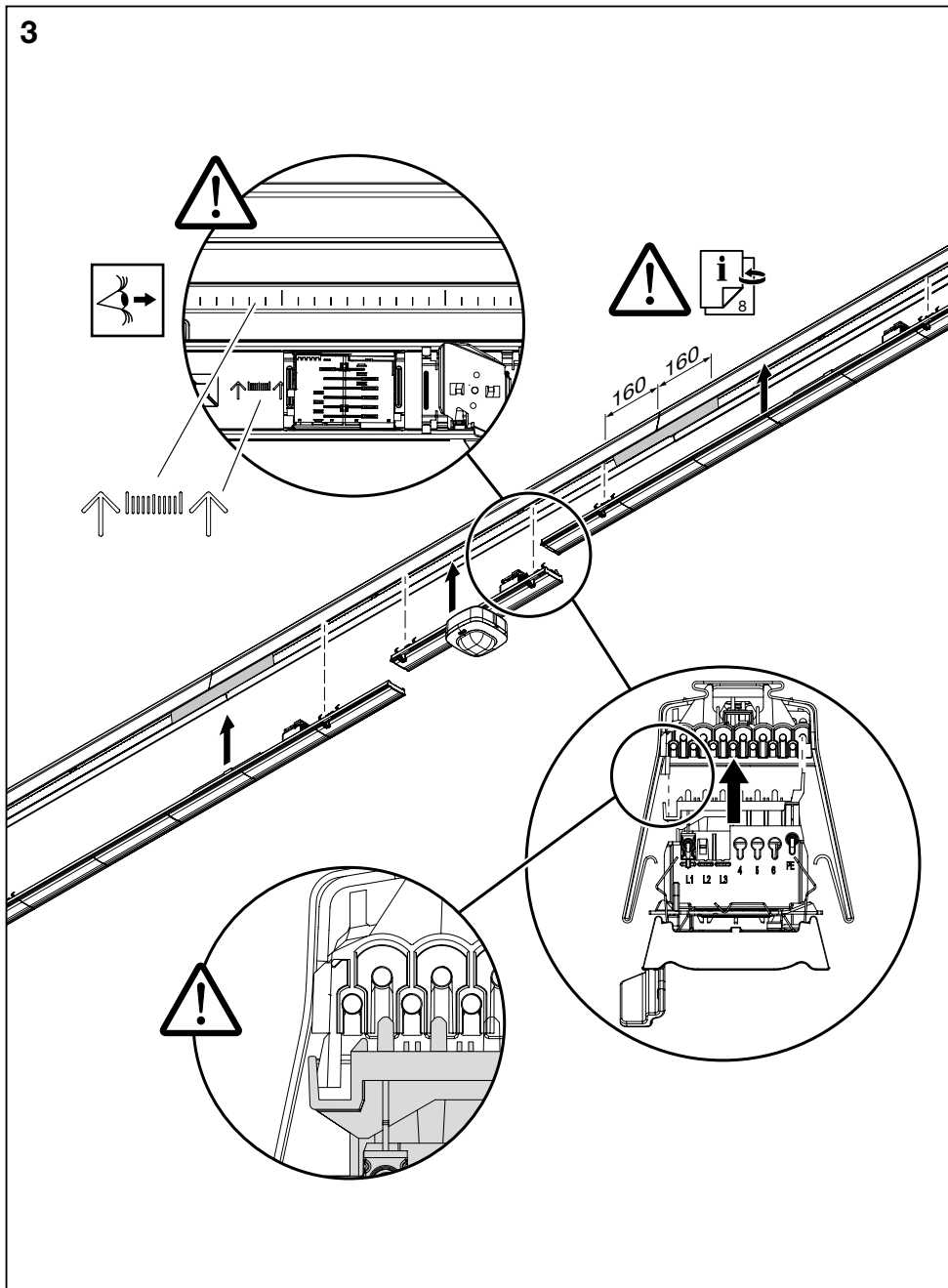

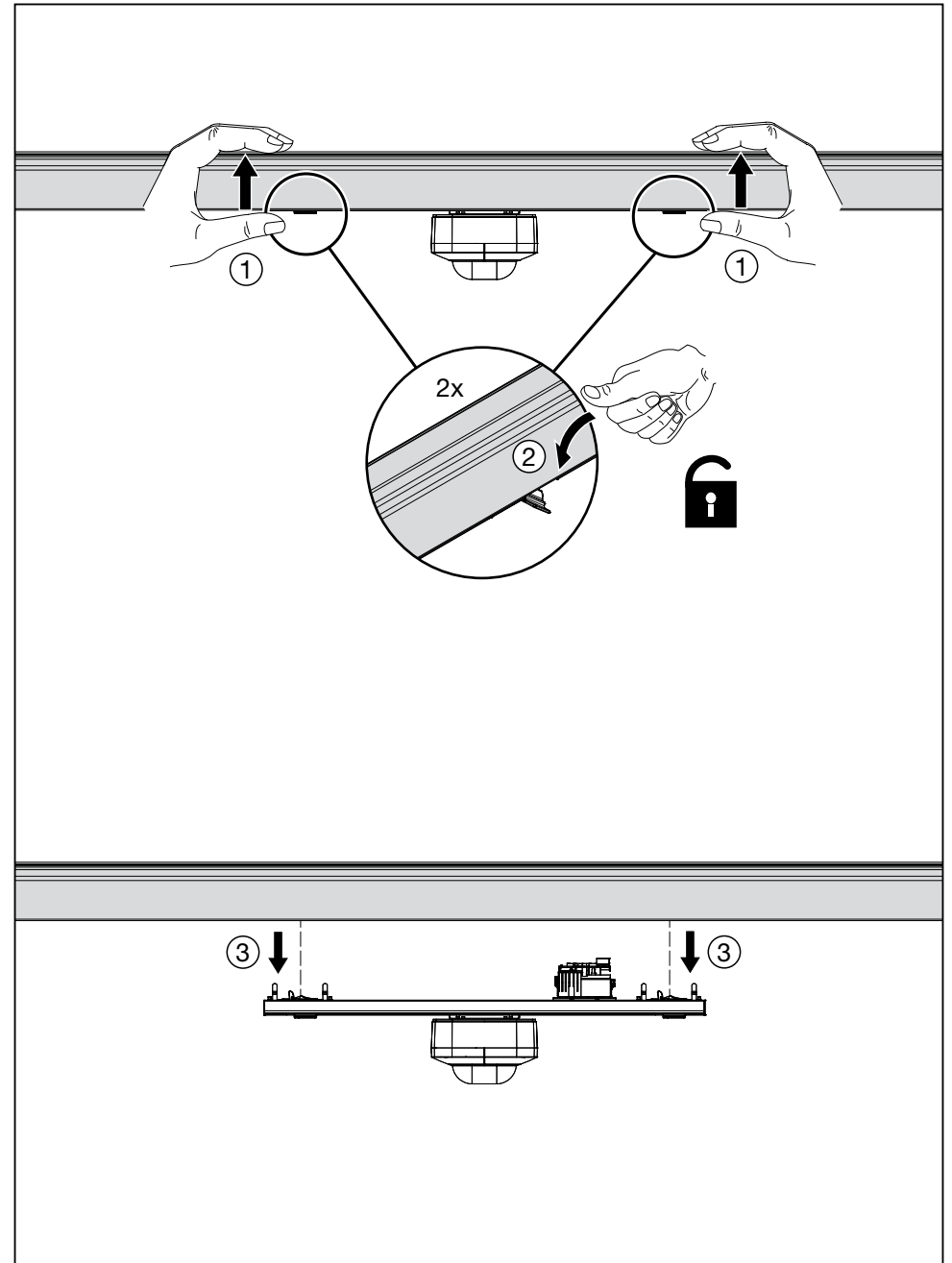
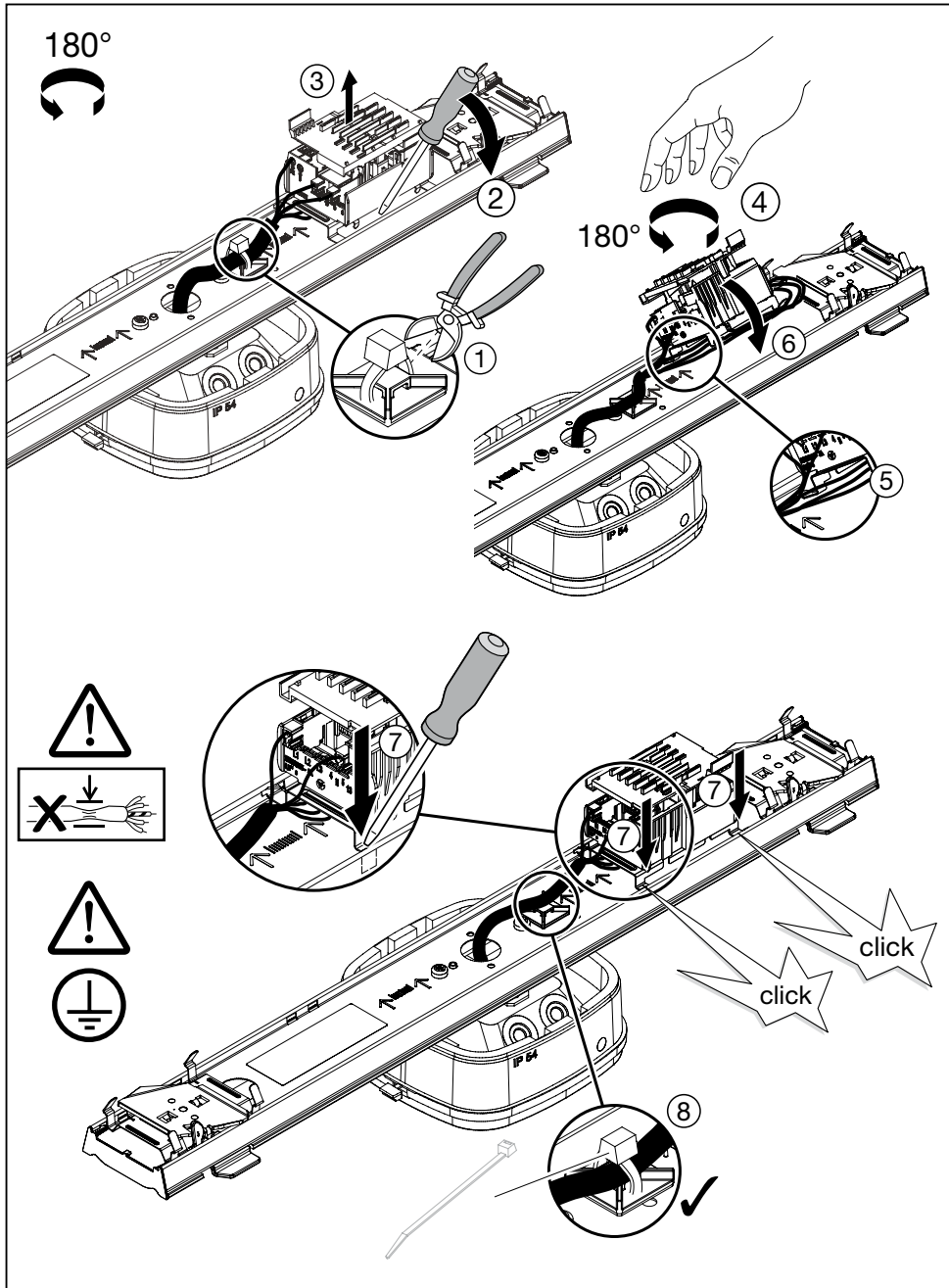

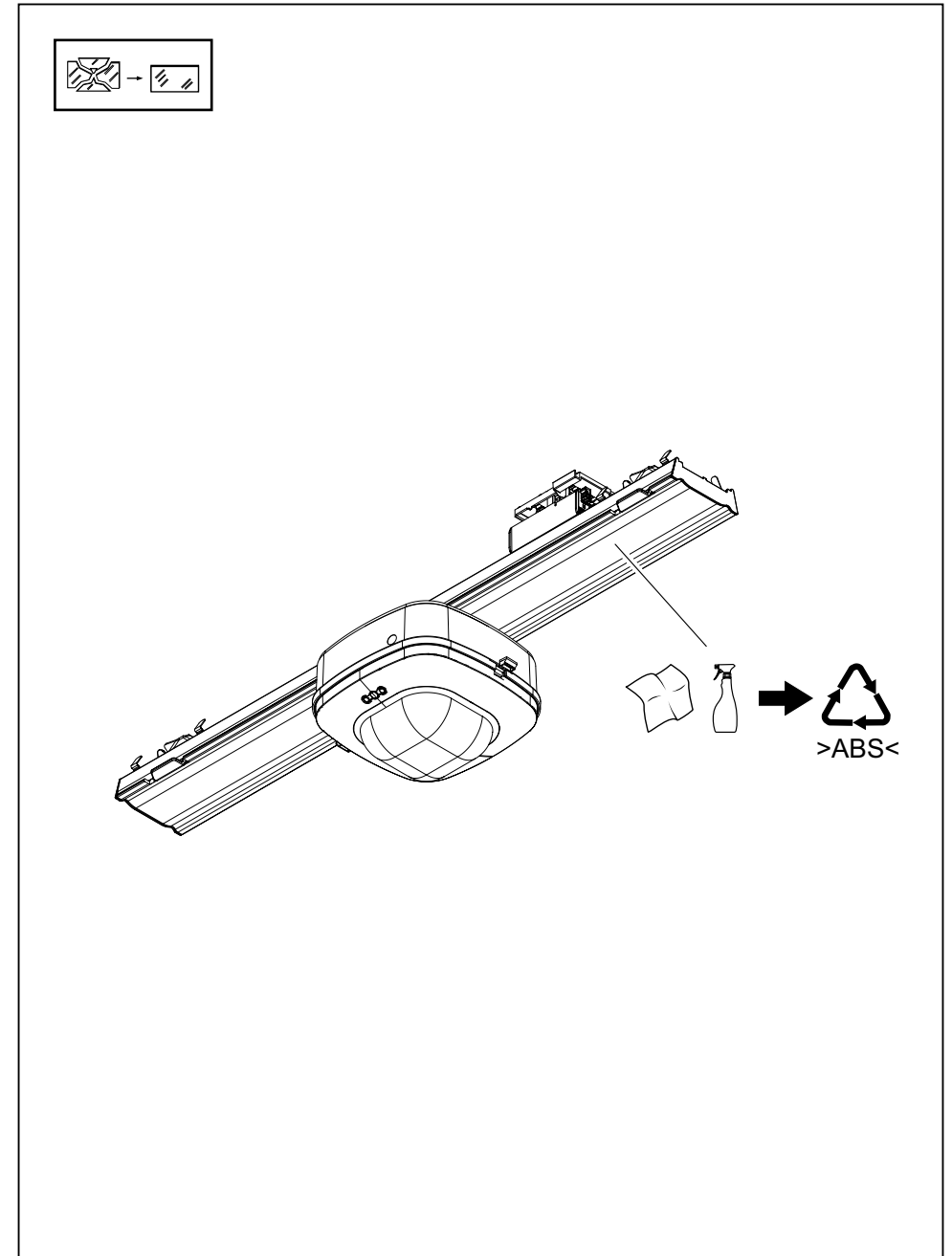
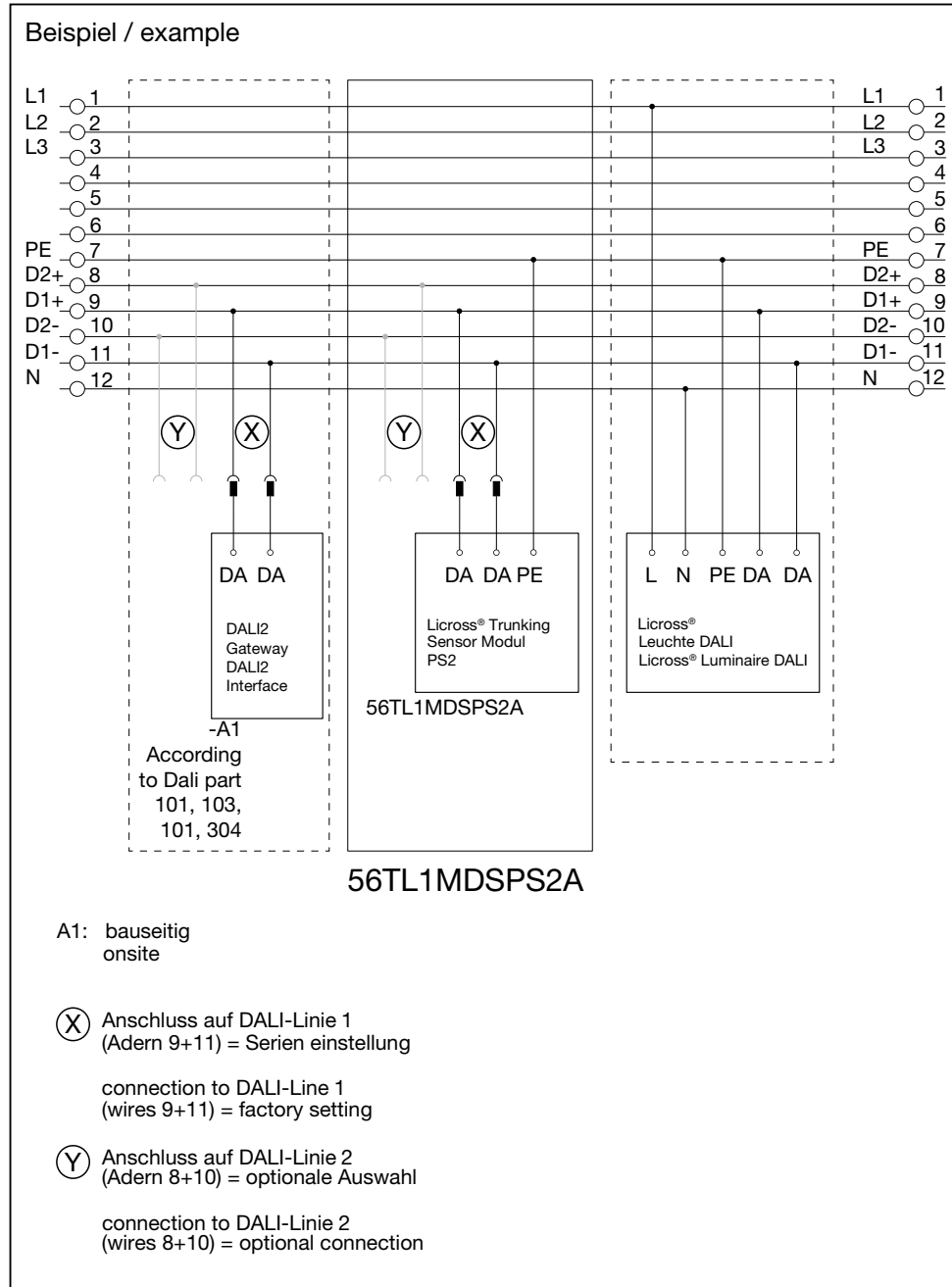



+



Ⓜ Zur Verwendung in einer Umgebung, in der keine ungewöhnliche Staubablagerung erwartet wird. Ⓜ For use in an environment in which unusual dust deposits are not expected. Ⓜ Destiné à être utilisé dans un environnement dans lequel il n'y a pas d'accumulation inhabituelle de poussière. Ⓜ Da usare in ambienti in cui non si prevedono depositi di polvere insoliti. Ⓜ Para aplicaciones en un entorno en el cual no se espera una acumulación inusual de polvo. Ⓜ Para uso em ambiente, no qual não se prevê acumulação anormal de poeiras. Ⓜ Για χρήση σε περιβάλλον στο οποίο δεν αναμένεται ασυνήθης συσσώρευση σκόνης. Ⓜ Voor gebruik in een omgeving, waar geen ongebruikelijke stofafzettingen worden verwacht. Ⓜ För användning i en miljö där ingen onormal mängd av damm förväntas. Ⓜ Käytettäväksi ympäristöissä, joissa ei ole odotettavissa epätavallisia pölykertymiä. Ⓜ For bruk i miljøer der det ikke forventes uvanlig mye støv. Ⓜ Til brug i miljøer, hvor der ikke forventes usædvanlig støvaflejring. Ⓜ Pro použití v prostředí, kde se neočekává neobvyklé usazování prachu. Ⓜ Для использования в местах, где сильное оседание пыли не предвидится. Ⓜ Olyan környezetben használható, ahol nem várható szokatlan porlerakodás. Ⓜ Do użytku w środowisku, w którym nie przewiduje się gromadzenia na oprawie kurzu (pyłu). Ⓜ Na použitie v prostredí, v ktorom sa neočakáva nezvyčajné usadzovanie prachu. Ⓜ Za uporabo v okolju, kjer ni pričakovano neobičajno kopičenje prahu. Ⓜ Olağan dışı toz birikmesi beklenmeyen bir ortamda kullanım içindir. Ⓜ Za uporabu u okolini, u kojoj se ne očekuju neobičajene naslage prašine. Ⓜ Pentru utilizare într-un mediu în care se aşteaptă o acumulare neobişnuită de praf. Ⓜ Предназначени за среда, в която не се очаква необичайно отлагане на прах. Ⓜ Kasutamiseks tolmuvabas keskkonnas. Ⓜ Skirta naudoti aplinkoje, kurioje nesikaupia neįprastos dulkiės. Ⓜ Izmantosanai vidē, kurā nav paredzama netipisku putekļu uzkrāšanās. Ⓜ Za upotrebu u okruženju gde se ne očekuje neobičajno velika akumulacija prašine. Ⓜ Для використання в середовищі, в якому незвичне згущення пилу не очікується. Ⓜ Шаңның қалыпсыз жиналуы болмайтын сыртқы ортада қолдану үшін.



5MA63-256852\_ae  
06.03.2025 / PZ

Siteco GmbH  
Georg-Simon-Ohm-Straße 50  
83301 Traunreut, Germany  
mail: [technicalsupport@siteco.de](mailto:technicalsupport@siteco.de)  
Phone: +49 8669 / 33-844  
[www.siteco.com](http://www.siteco.com)