

Floodlight FL 21 mini

5XA777...

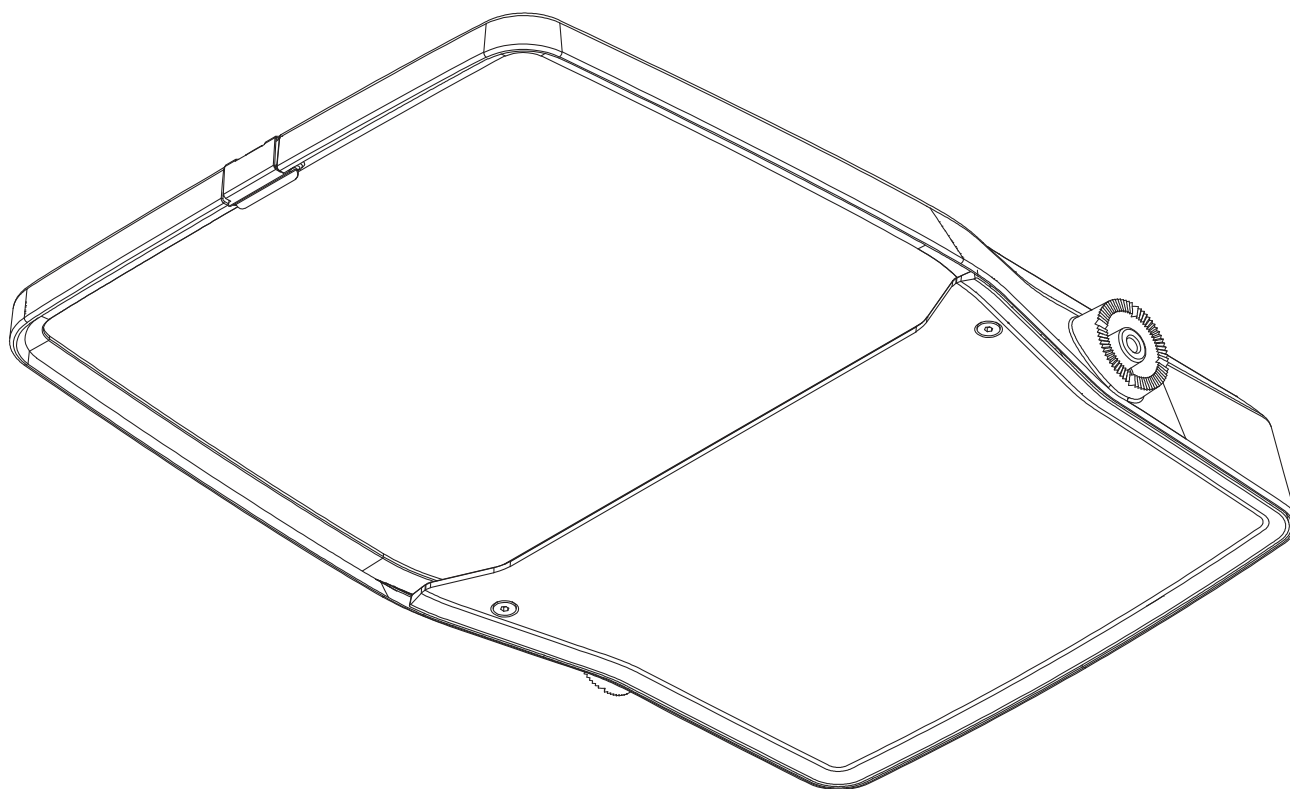

siteco

Floodlight FL 21 mini

[mm]

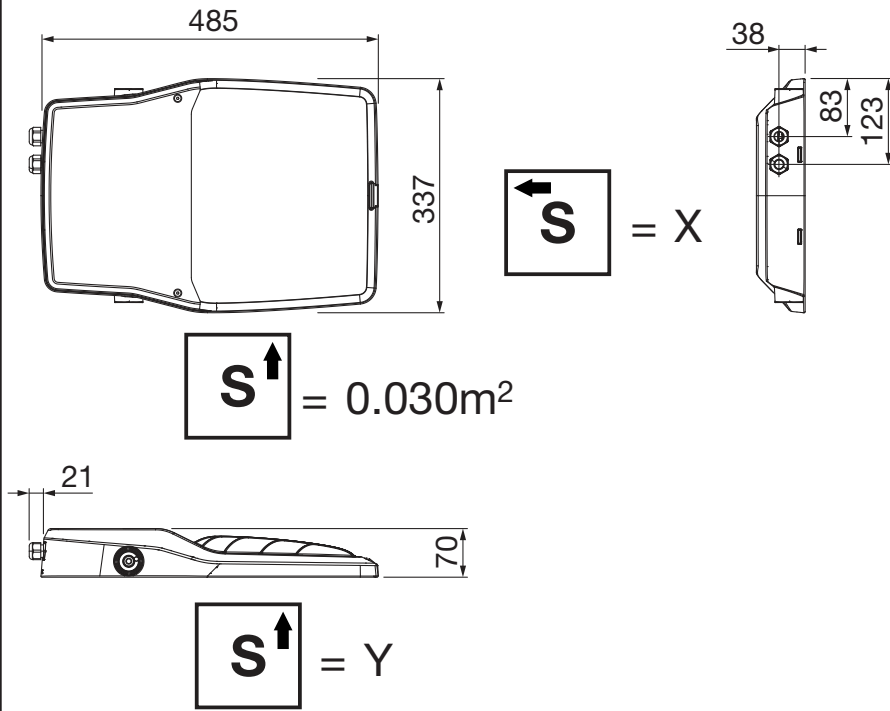

	X	Y
0°	0.03m ²	0.16m ²
5°	0.03m ²	0.16m ²
10°	0.04m ²	0.16m ²
15°	0.05m ²	0.15m ²
20°	0.06m ²	0.15m ²
25°	0.07m ²	0.15m ²
30°	0.08m ²	0.14m ²
35°	0.10m ²	0.14m ²
40°	0.11m ²	0.13m ²
45°	0.11m ²	0.12m ²
50°	0.12m ²	0.11m ²
55°	0.13m ²	0.10m ²
60°	0.14m ²	0.09m ²
65°	0.14m ²	0.08m ²
70°	0.15m ²	0.07m ²

kg ≤ 6.0

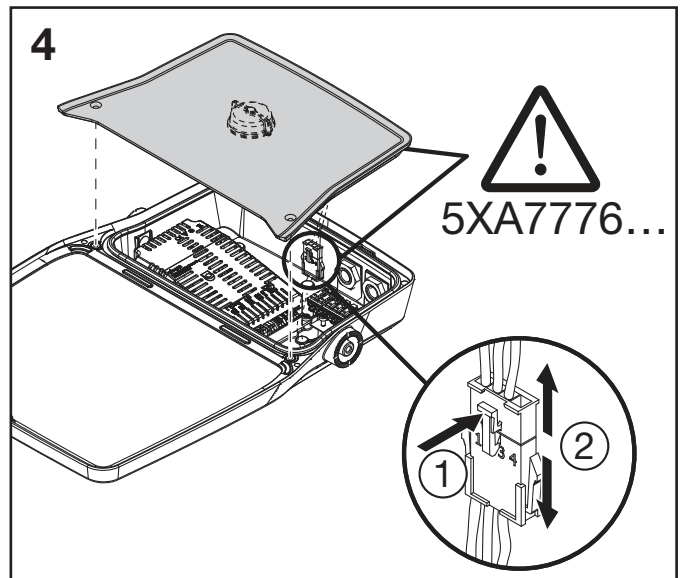
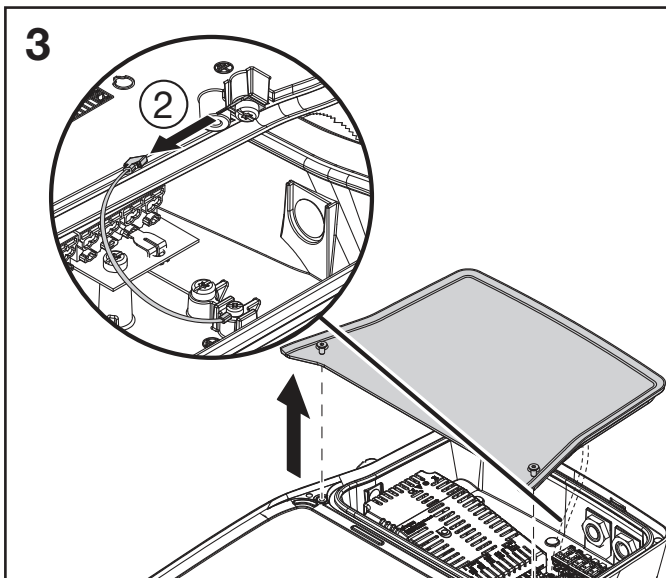
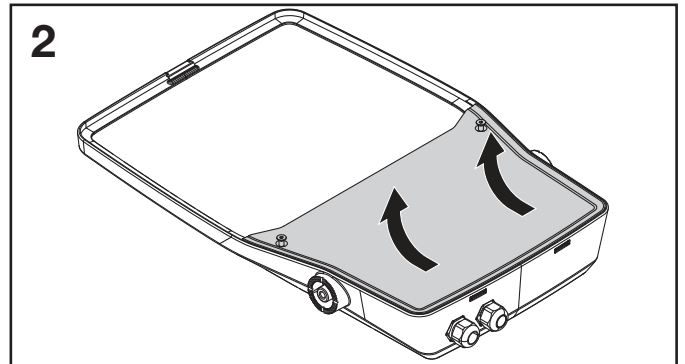
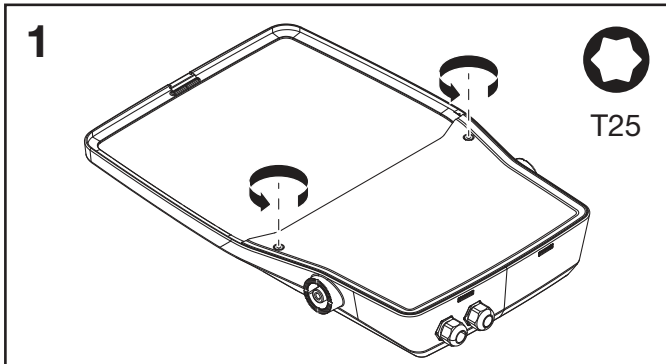

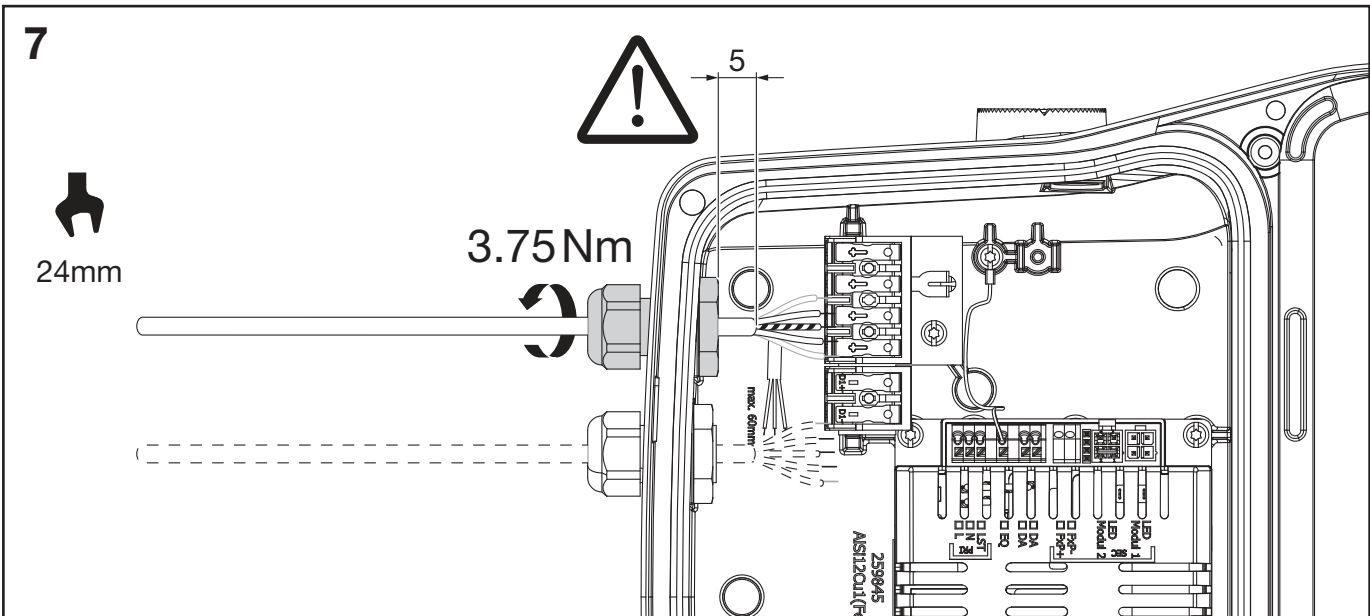
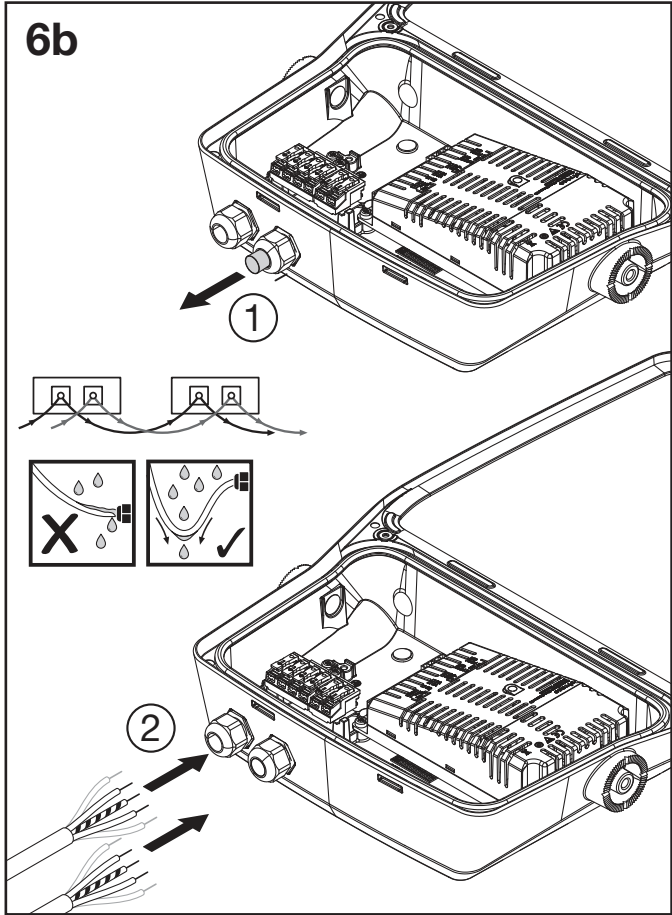
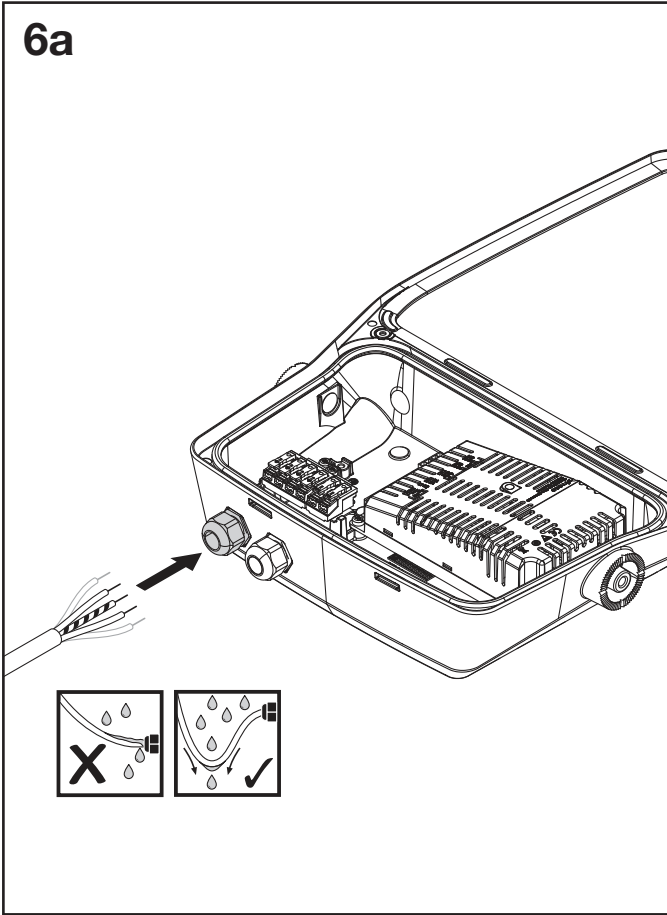
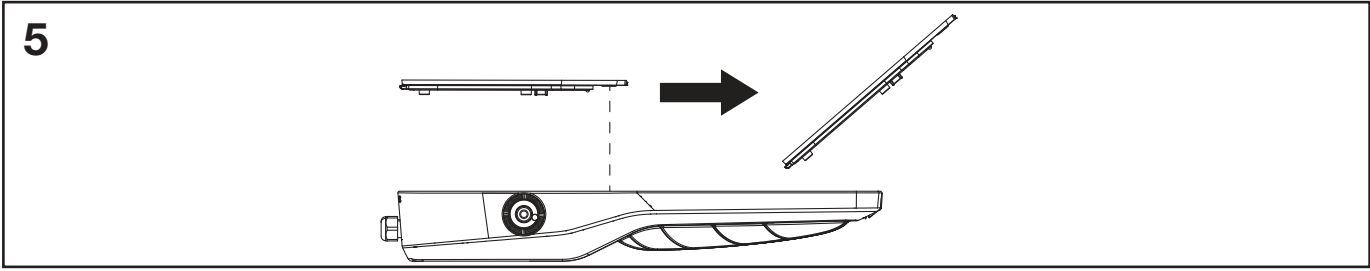

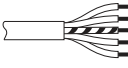
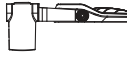
			L	N	E	PE	LST	DA	DA
iQ Comfort	5	5XA...1...	x	x	x			x	x
iQ Comfort	4	5XA...1...	x	x				x	x
iQ Comfort	4	5XA...1...	x	x	x		x		
iQ Comfort	3	5XA...1...	x	x			x		
iQ Comfort	3	5XA...1...	x	x	x				
iQ Comfort	2	5XA...1...	x	x					
iQ Street Remote	5	5XA...2...	x	x	x			x	x
iQ Street Remote	4	5XA...2...	x	x				x	x
iQ Street Remote	4	5XA...2...	x	x	x		x		
iQ Street Remote	3	5XA...2...	x	x			x		
iQ Street Remote	3	5XA...2...	x	x	x				
iQ Street Remote	2	5XA...2...	x	x					
ON/OFF - Multilumen	3	5XA...3...	x	x		x		N. C.	N. C.
DALI - AC/DC	5	5XA...4...	x	x	x			x	x
DALI - AC/DC	4	5XA...4...	x	x				x	x
Smart Interface oben	3	5XA...5...	x	x	x				
Smart Interface oben	2	5XA...5...	x	x					
Smart Interface oben/unten	3	5XA...6...	x	x	x				
Smart Interface oben/unten	2	5XA...6...	x	x					

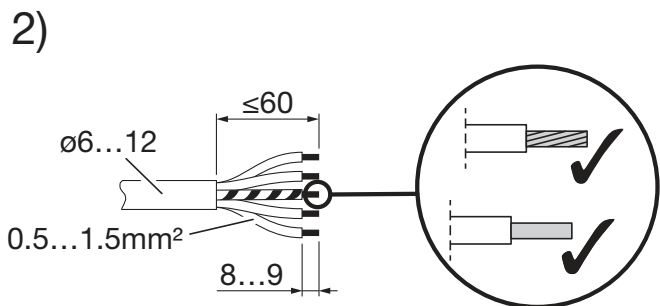
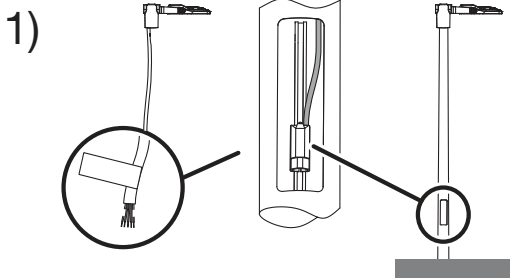

5XA...3...

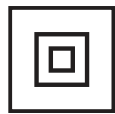

5XA...1...
5XA...2...
5XA...4...
5XA...5...
5XA...6...

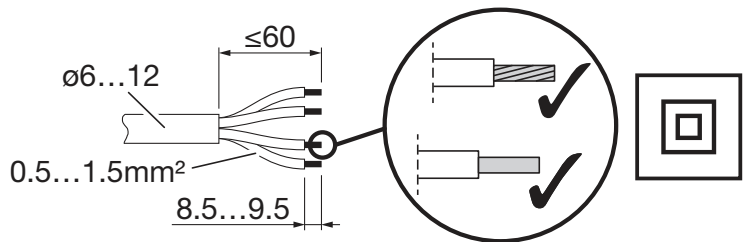



3)

iQ Comfort LST
iQ Street Remote LST



LST = 0V = 100% 



LST = 230V = 100% 
LST = 0V = 50% 

LST 230V  → 20min. ↑

	Strom (A)	Peak-Länge (µs)	B6	C6	B10	C10	B16	C16	B20	C20
5XA7771B... 5XA7772B...	5	100	15	15	25	25	40	40	50	50
5XA7775B... 5XA7776B...	12	100	11	11	18	18	30	30	36	36
5XA7771C... 5XA7771D... 5XA7772C... 5XA7772D... 5XA7773C...	24	190	7	7	11	11	18	18	23	23
5XA7774C...	58	340	3	4	4	7	7	12	9	15
5XA7775C... 5XA7775D... 5XA7776C... 5XA7776D...	11.5	100	5	5	8	8	13	13	17	17

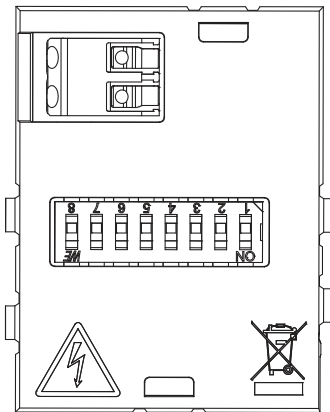

5XA7773...								
	DIP							
Lichtstrom	1	2	3	4	5	6	7	8
100%	ON							
		OFF	OFF	OFF	OFF	OFF	OFF	OFF
90%		ON						
	OFF		OFF	OFF	OFF	OFF	OFF	OFF
80%			ON					
	OFF	OFF		OFF	OFF	OFF	OFF	OFF
70%				ON				
	OFF	OFF	OFF		OFF	OFF	OFF	OFF
60%					ON			
	OFF	OFF	OFF	OFF		OFF	OFF	OFF
50%						ON		
	OFF	OFF	OFF	OFF	OFF		OFF	OFF
40%							ON	
	OFF	OFF	OFF	OFF	OFF	OFF		OFF
30%								ON
	OFF	OFF	OFF	OFF	OFF	OFF	OFF	

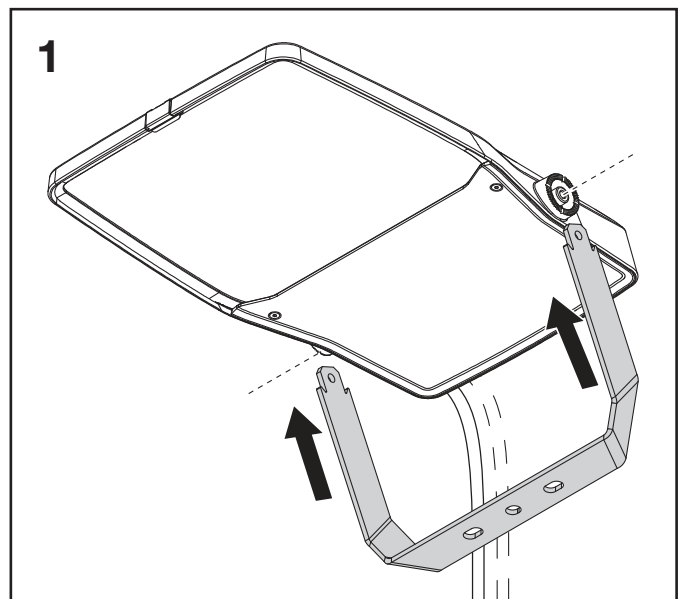
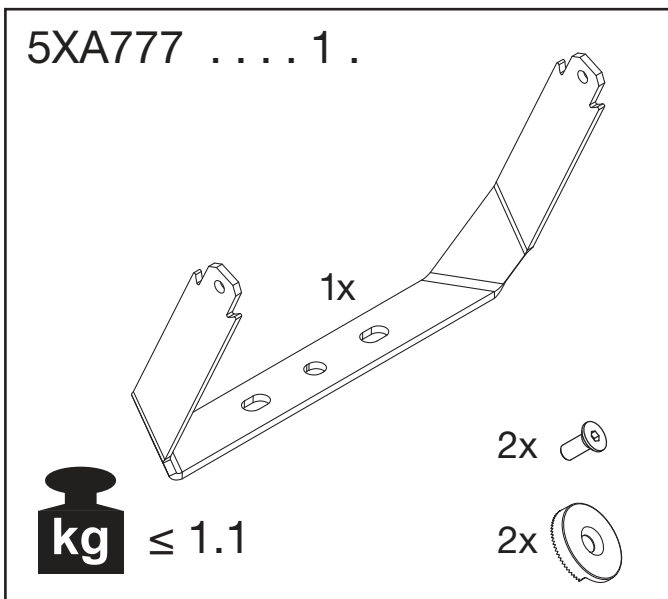
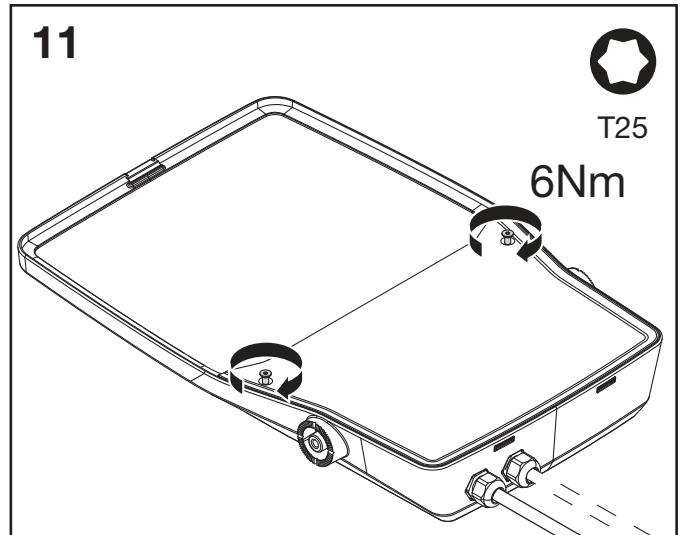
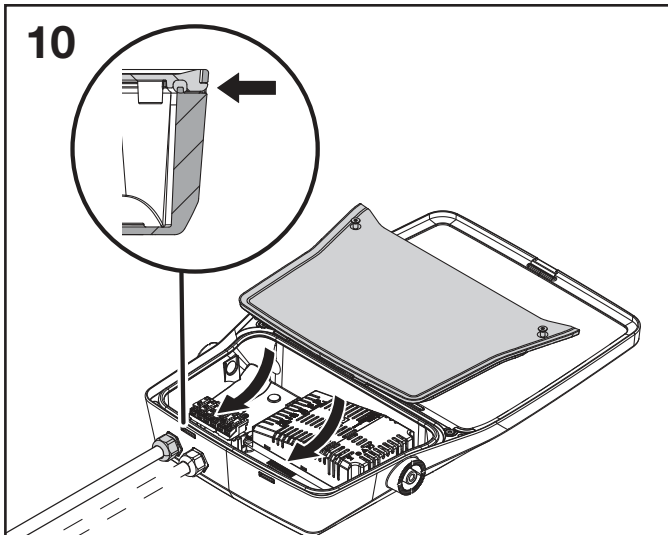
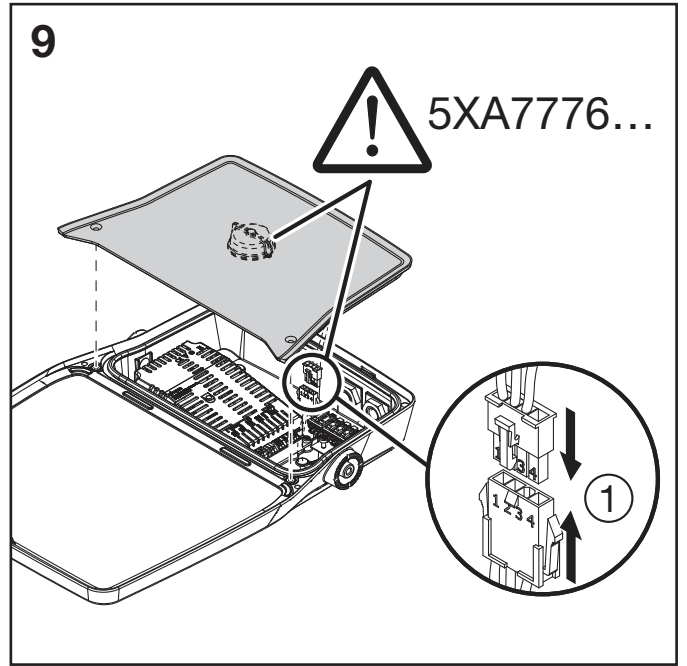
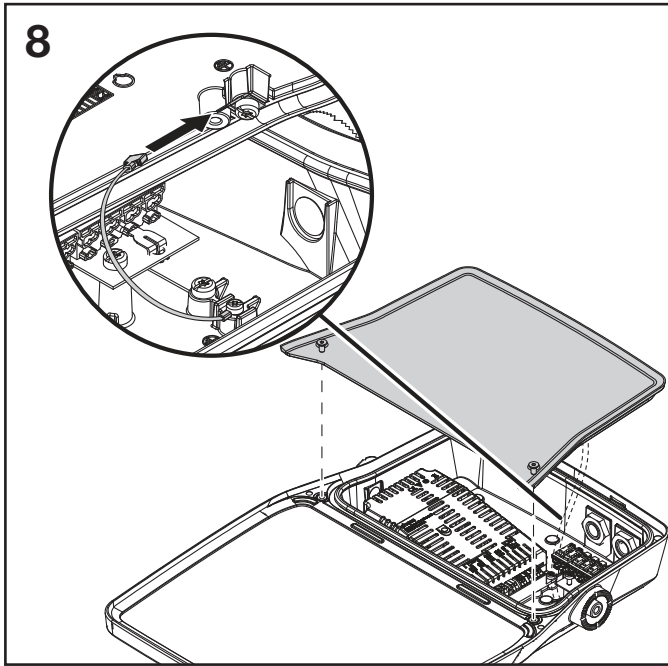

Floodlight FL 21 mini

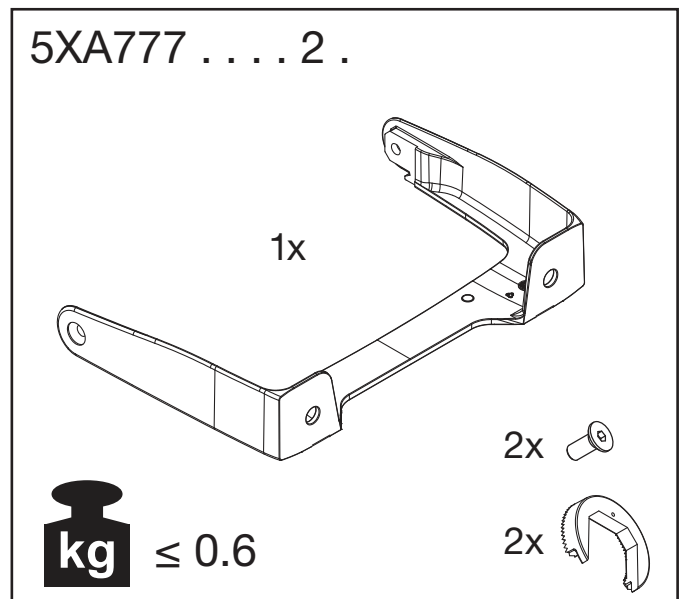
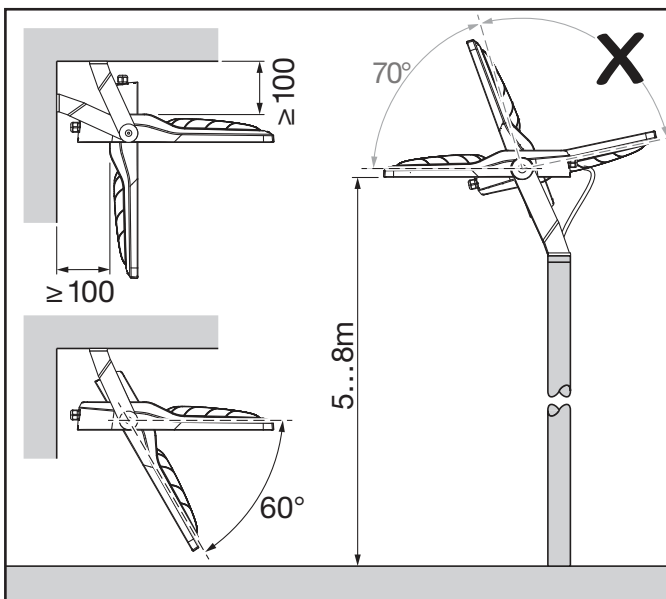
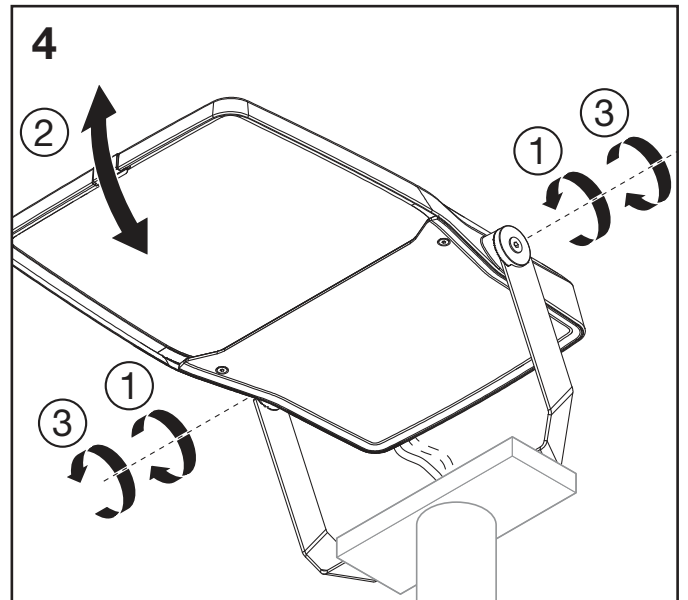
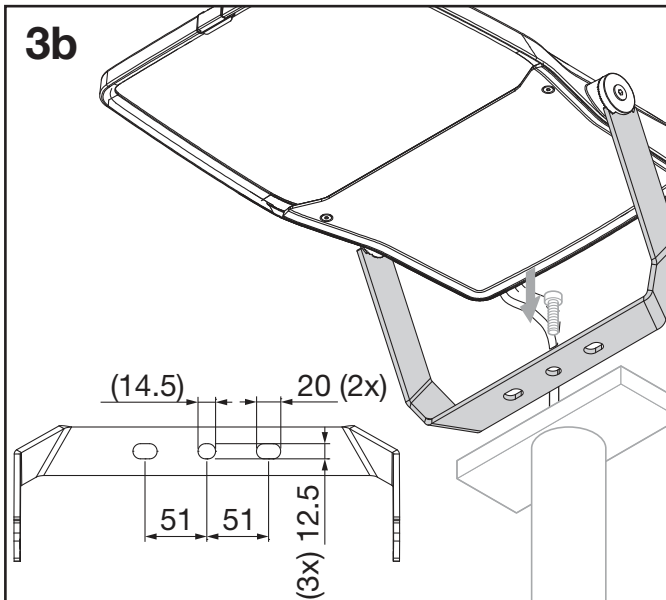
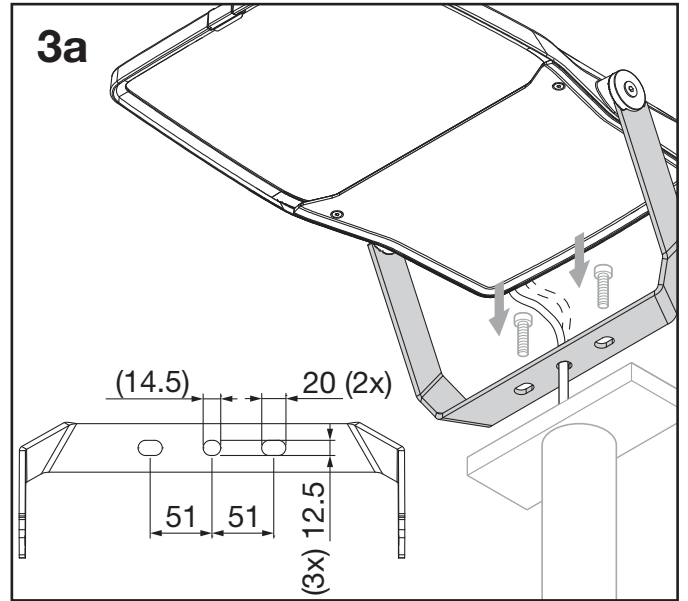
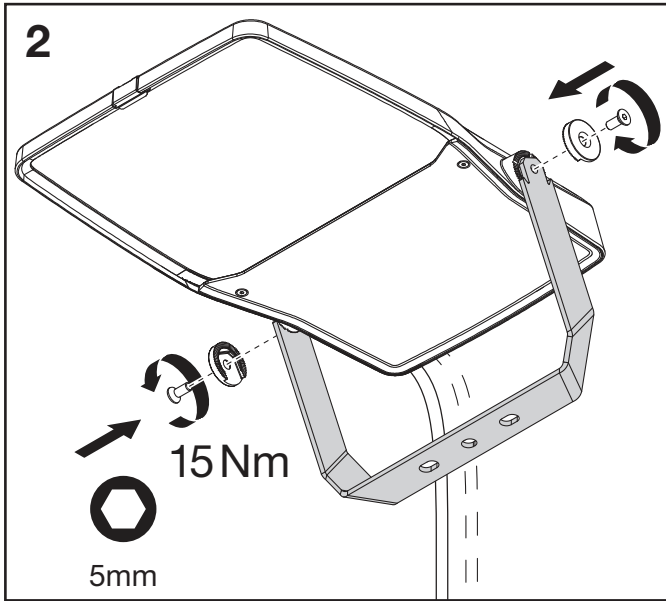

Floodlight FL 21 mini

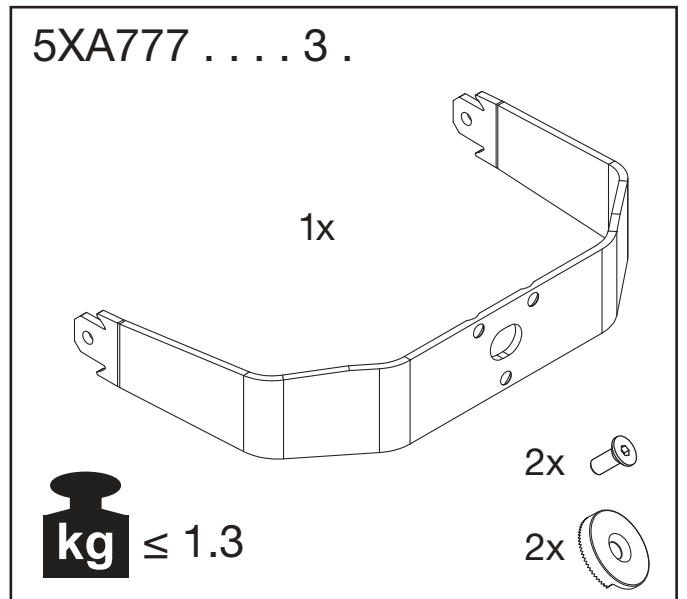
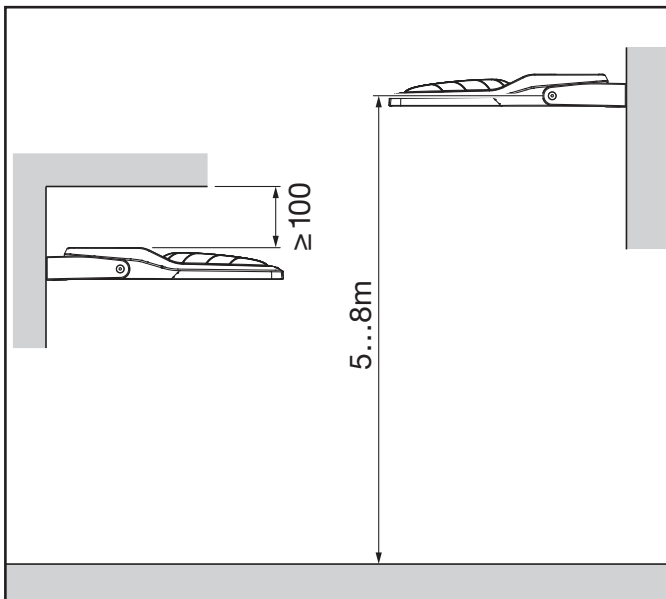
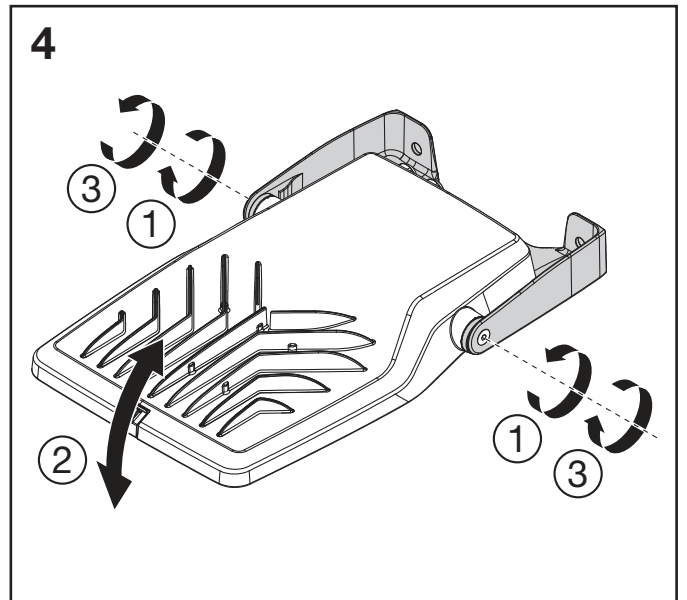
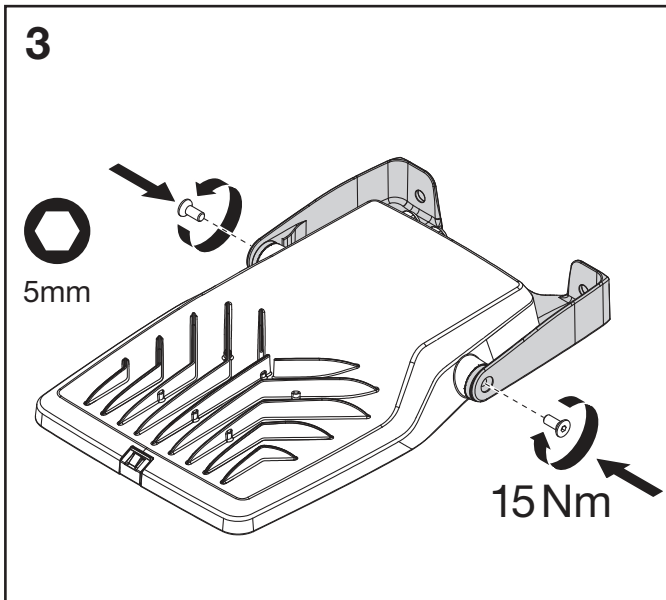
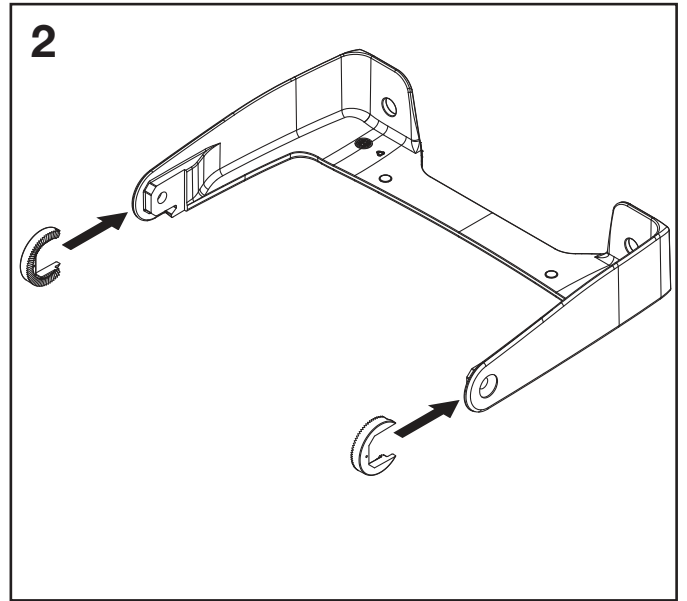
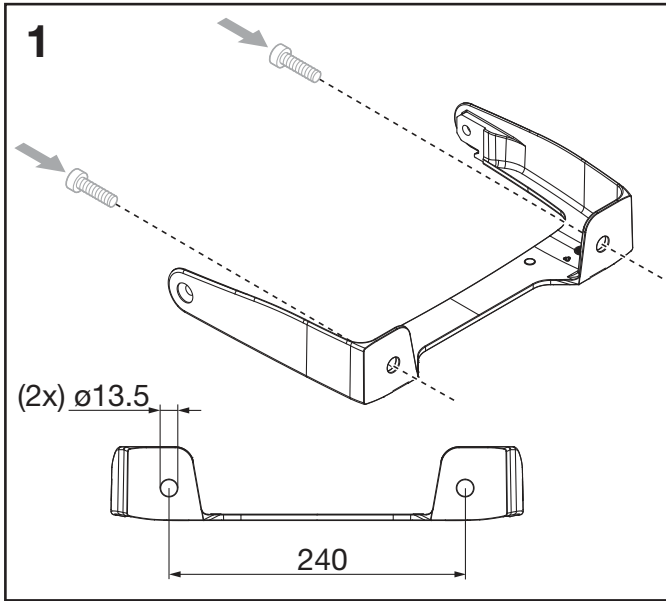

5XA77X42AN1

1x

$\text{kg} \leq 0.9$

2x 3x

5XA77X7660AN1

1x

$\text{kg} \leq 1.0$

2x 2x 3x

5XA77X42AU1

1x

$\text{kg} \leq 0.9$

2x 3x

5XA77X7660AU1

1x

$\text{kg} \leq 1.0$

2x 2x 3x

5XA77X42AU2

1x

$\text{kg} \leq 0.9$

1x 2x 6x

5XA77X7660AU2

1x

$\text{kg} \leq 1.0$

1x 2x 2x 6x

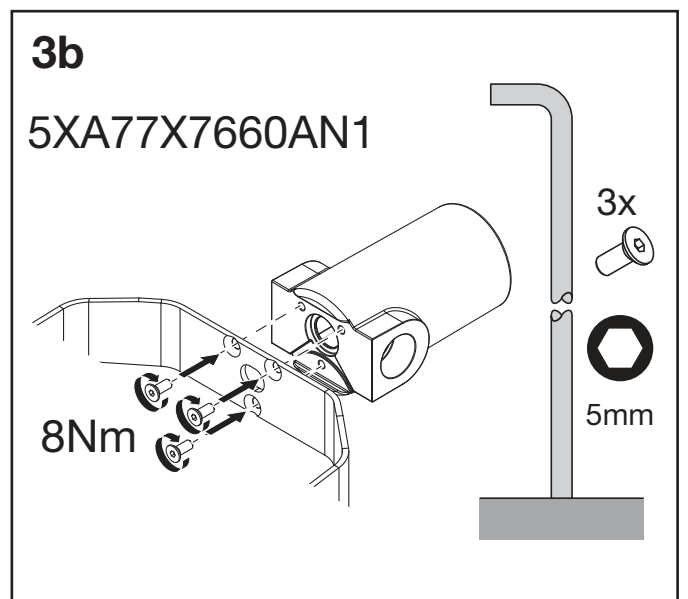
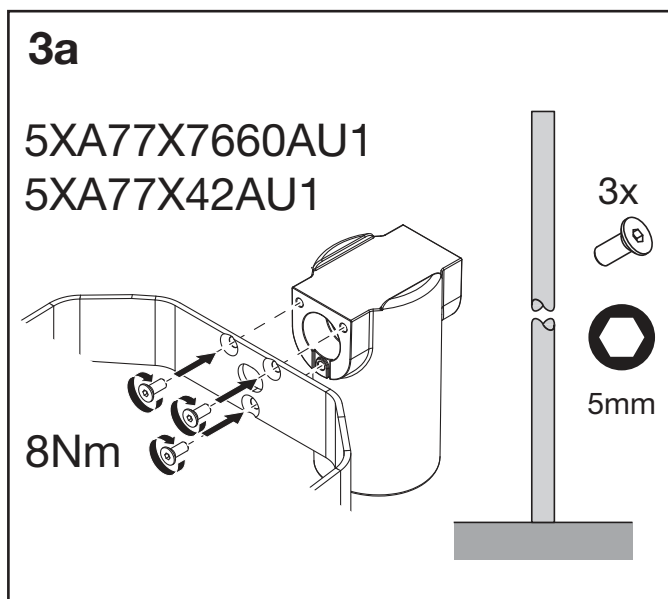
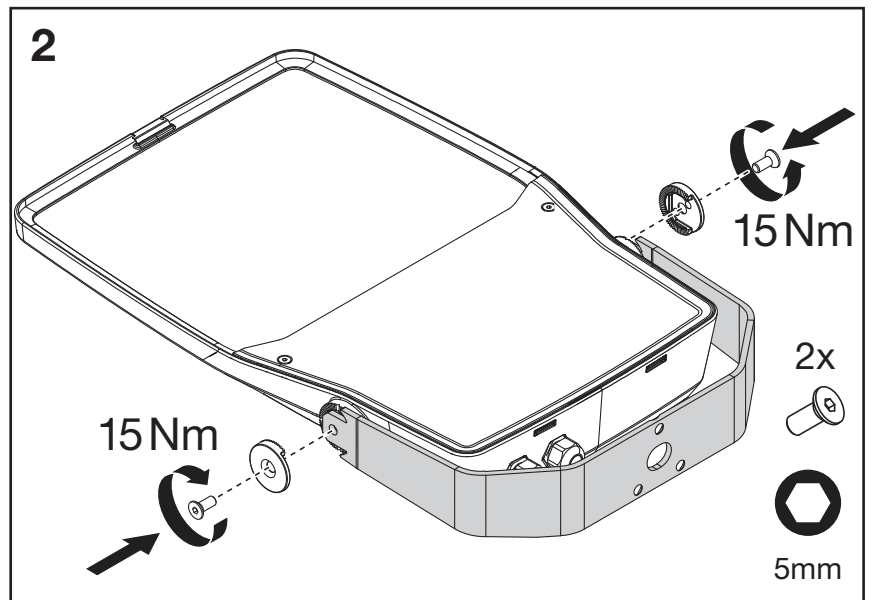
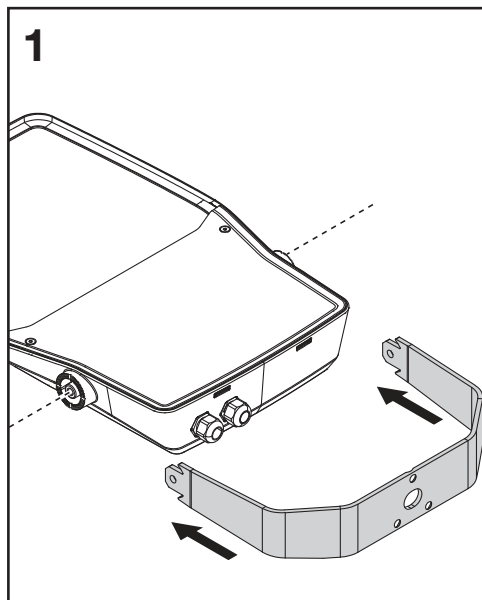
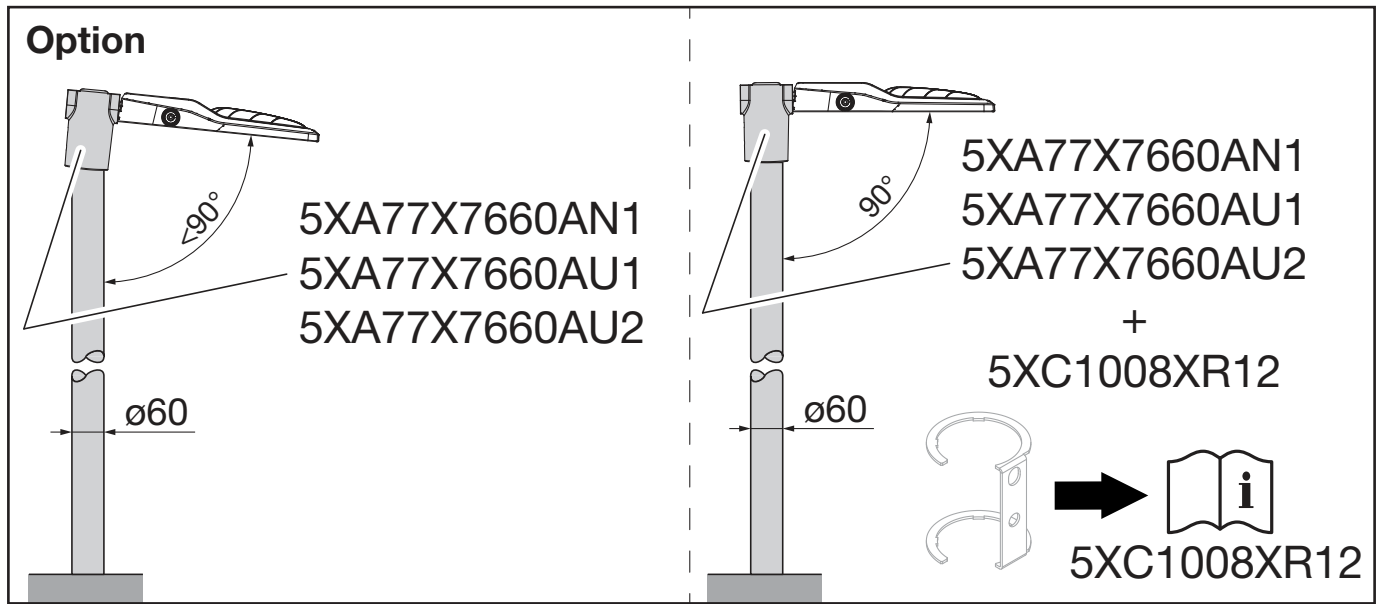

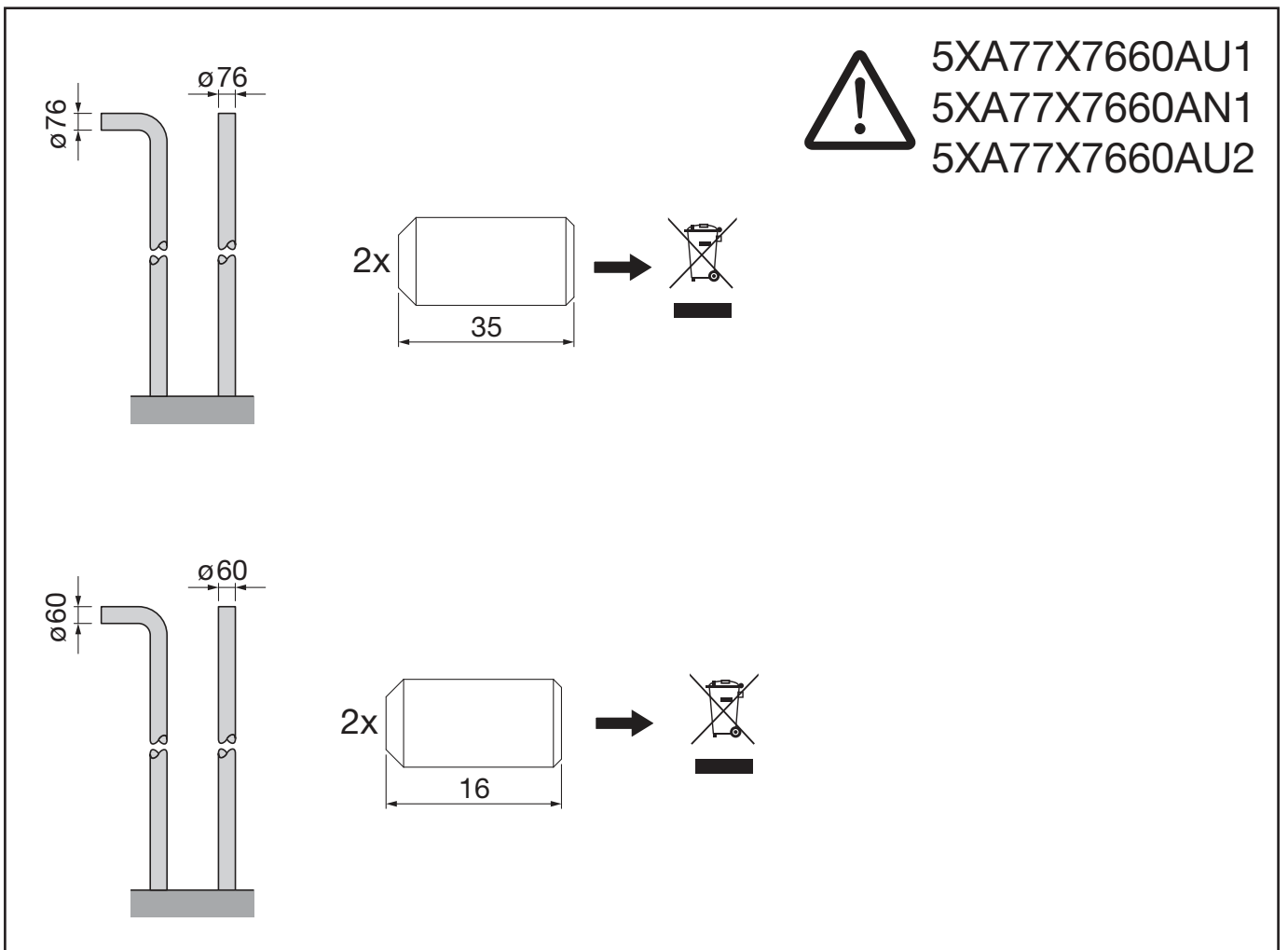
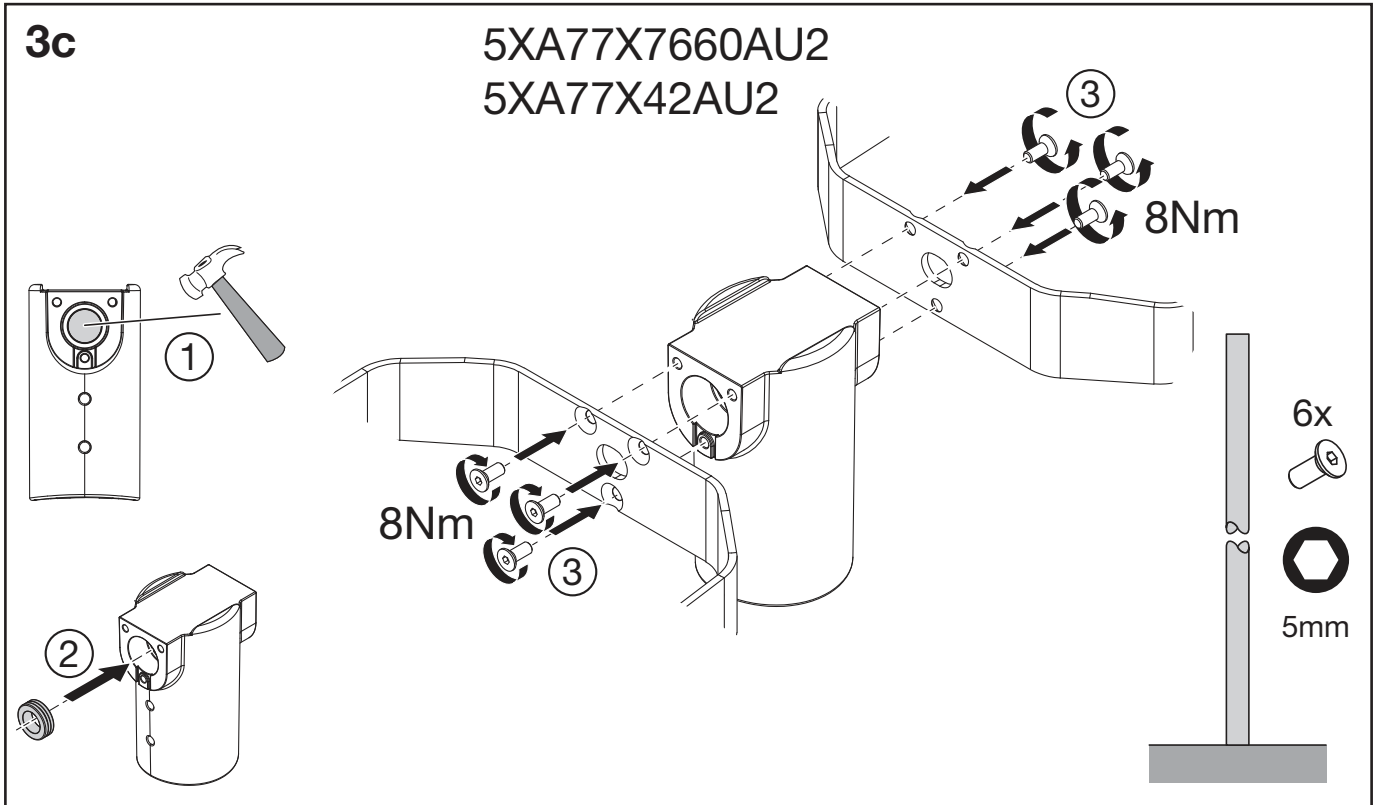

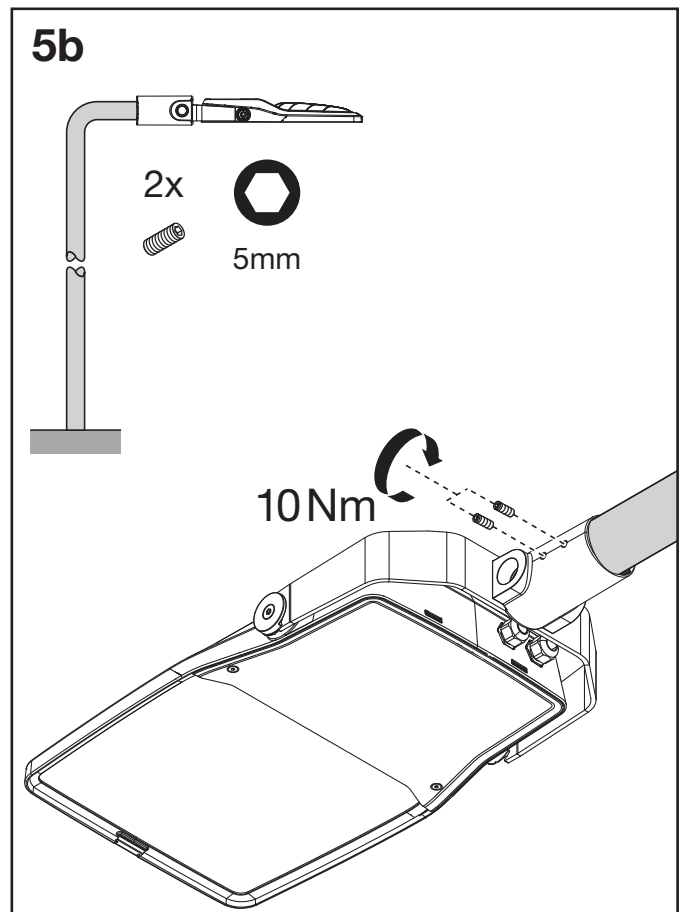
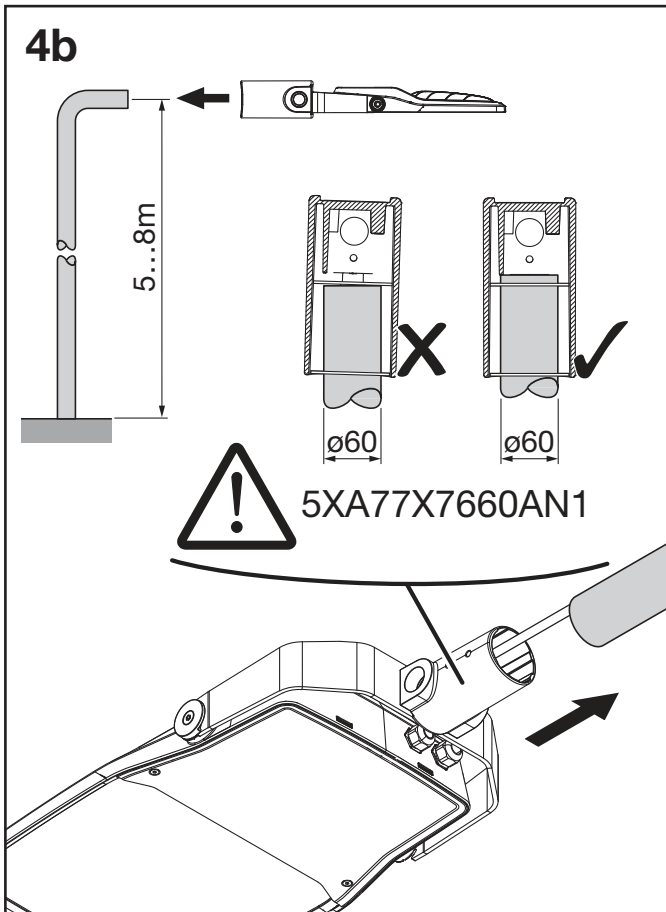
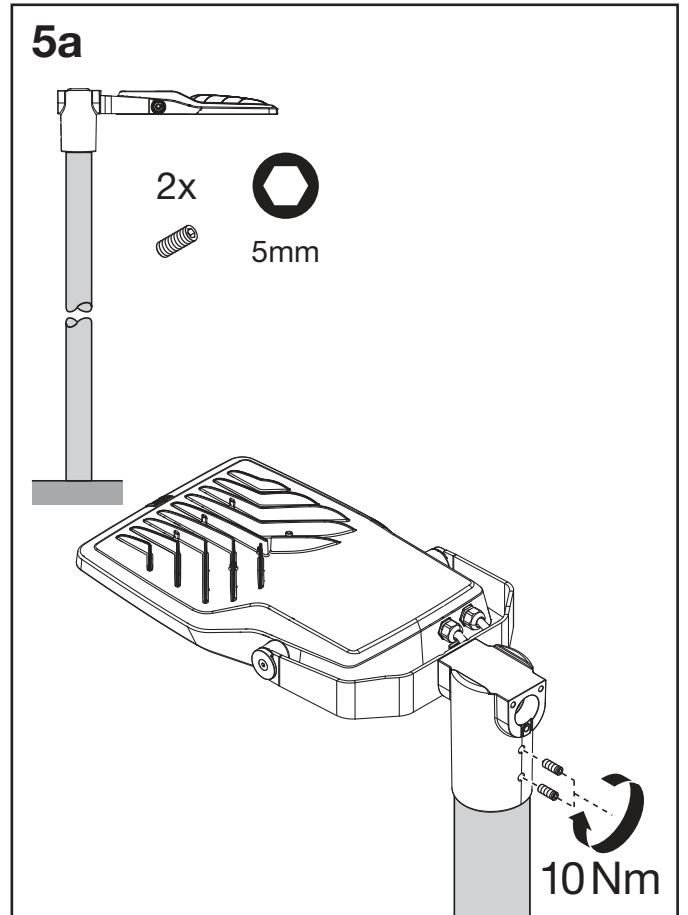
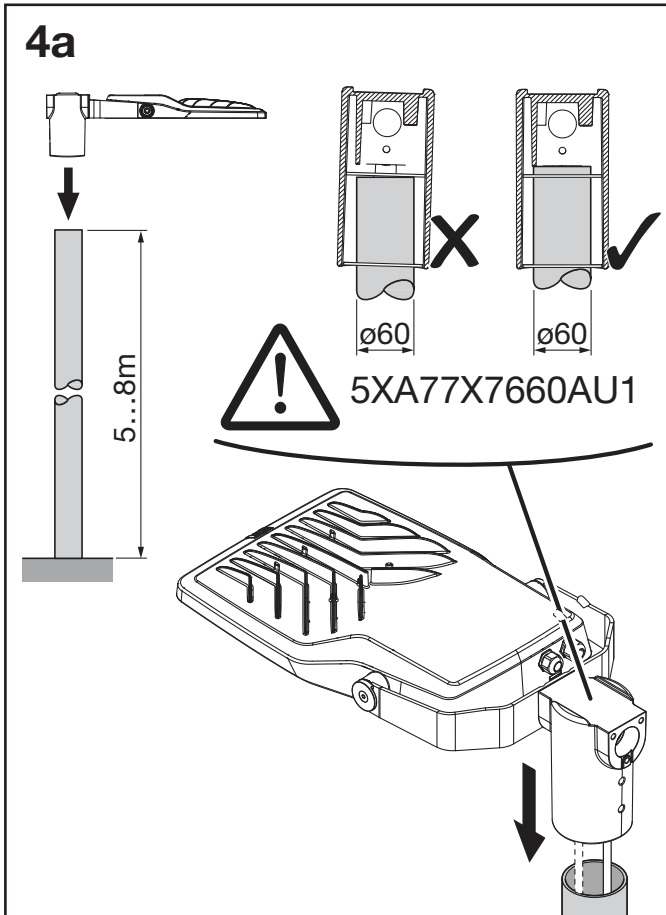

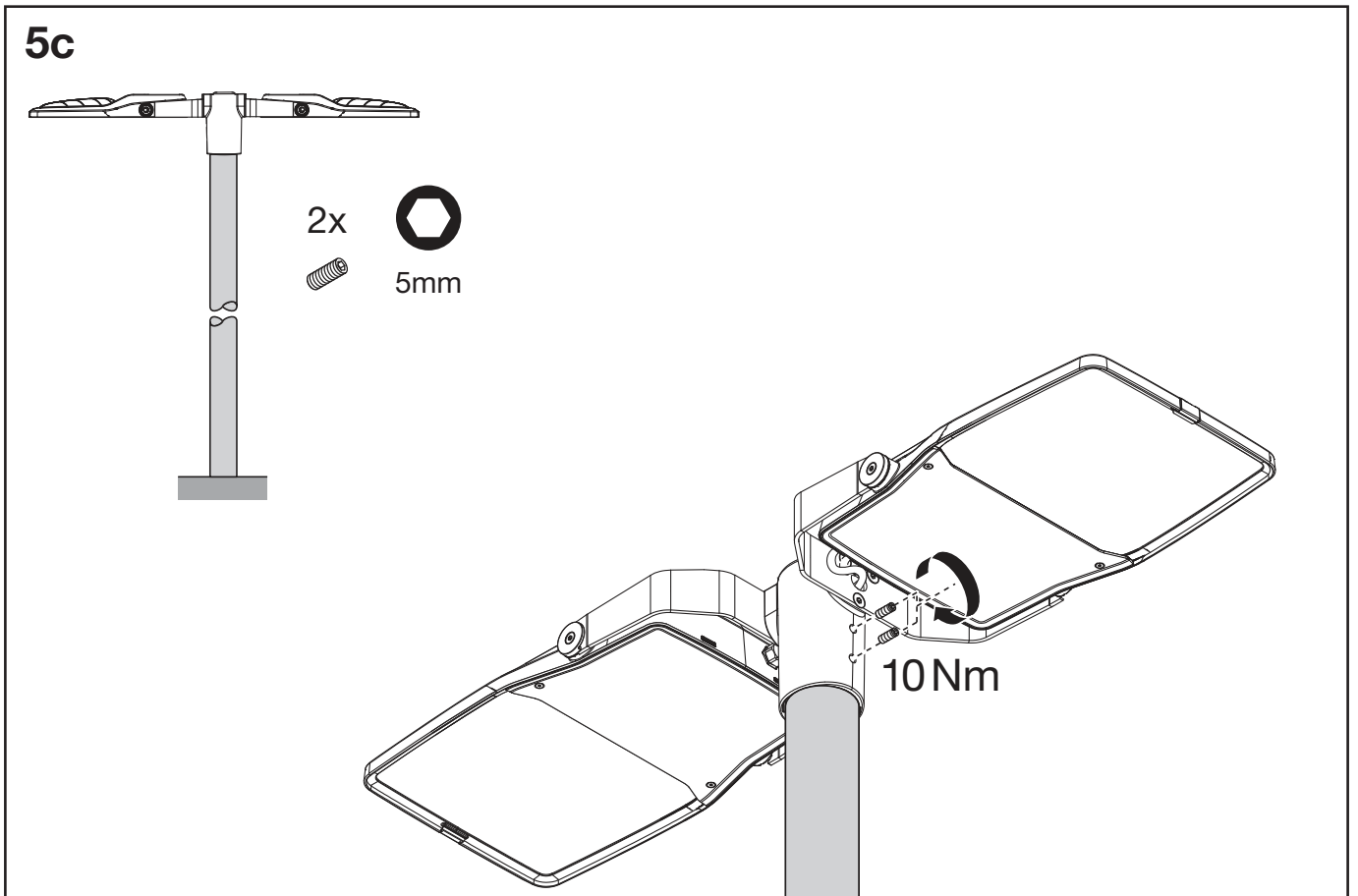
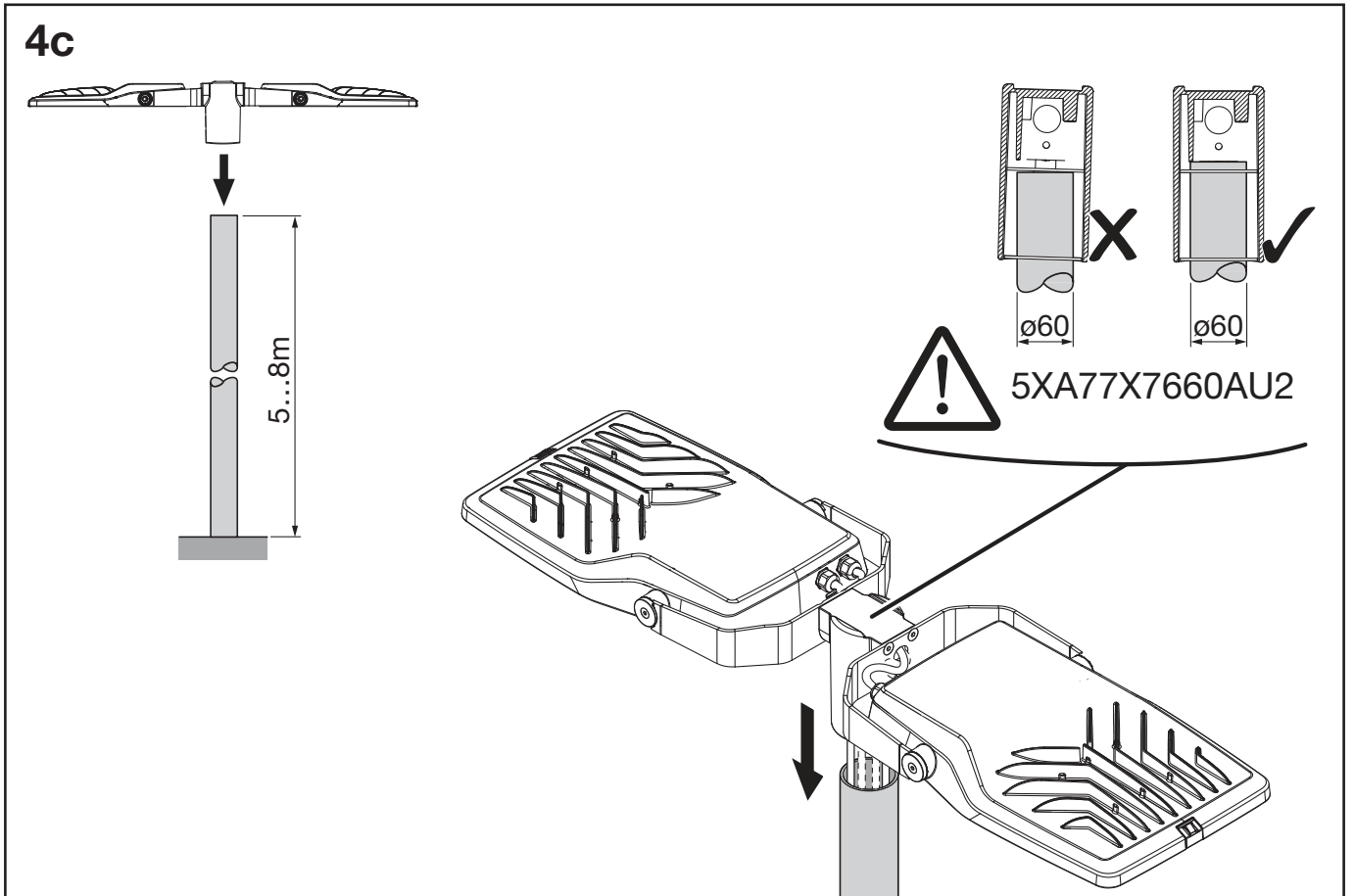

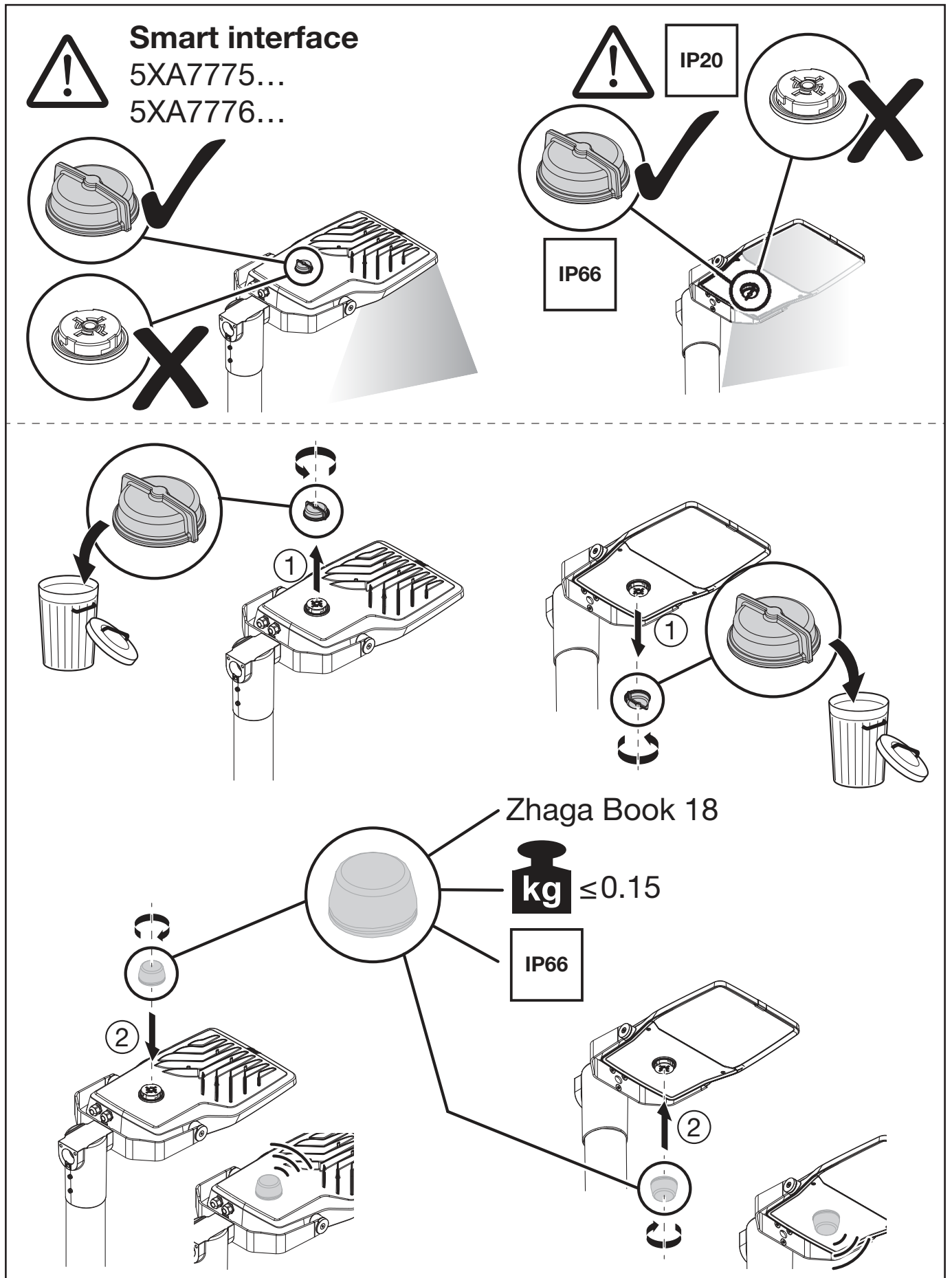

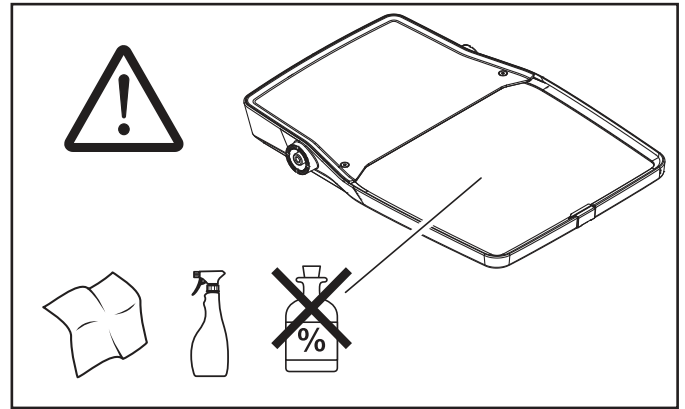
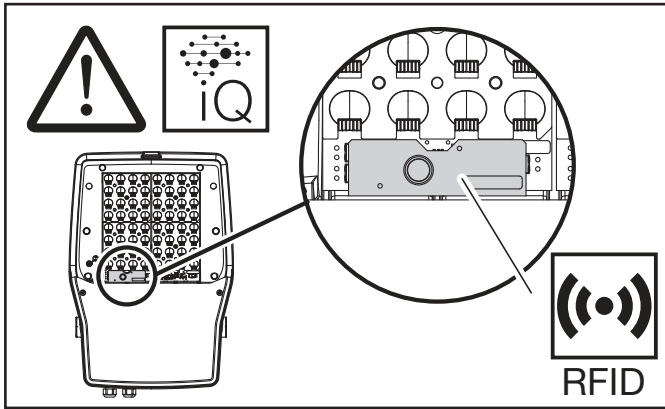

Die Lichtquelle sowie das Betriebsgerät entsprechen den Anforderungen der Ökodesign-Verordnung (EU) 2019/2020, diese sind gemäß dieser Verordnung austauschbar.

The light source and control gear comply with the requirements of the Ecodesign Regulation (EU) 2019/2020 and are interchangeable in accordance with this regulation.

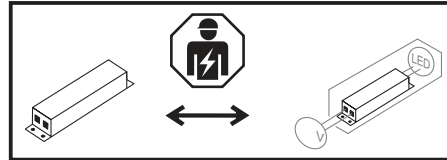
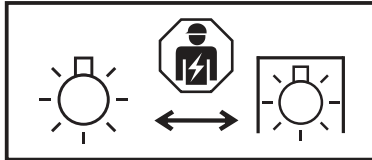

www.siteco.de/iq/iqapp

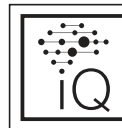

	RFID	BLE
Frequency	868 MHz	2.4 GHz
≤ HF-Power	0 mW	0.4 mW

Model	Energy Efficiency Class
5XA777 .. 2...	E
5XA777 .. 4...	E
5XA777 .. 5...	E
5XA777 .. 1...	F
5XA777 .. 3...	F

Dieses Produkt enthält eine Lichtquelle der Energieeffizienzklasse E oder F.
This product contains a light source of energy efficiency class E or F.

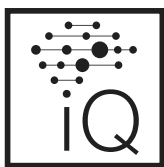

Ⓓ Hiermit erklärt die Siteco GmbH, dass der Funkanlagentyp der Richtlinie 2014/53/EU entspricht. Der vollständige Text der EU-Konformitätserklärung ist unter der folgenden Internetadresse verfügbar: <https://www.siteco.de/red-konformitaetserklaerung>

Ⓔ Hereby, Siteco GmbH declares that the radio equipment type is in compliance with Directive 2014/53/EU. The full text of the EU declaration of conformity is available at the following internet address: <https://www.siteco.com/red-conformity>

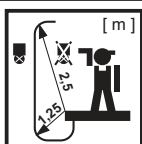

Ⓓ Außer Reichweite installieren. Ⓔ Only to be installed outside arms reach. Ⓕ Peut seulement être installé à l'extérieur sous abri. Ⓖ Da installare esclusivamente fuori dalla portata delle braccia. Ⓖ Sólo puede instalarse fuera del alcance de los brazos. Ⓖ Instalar apenas fora do alcance das pessoas. Ⓔ Na τοποθετείται έτσι, ώστε να μην πιάνεται με τα χέρια. Ⓖ Mag alleen geïnstalleerd worden buiten aanraakbereik. Ⓕ Får installeras endast utom räckhåll. Ⓔ Asennetaan kosketusetäisyyden ulkopuolelle. Ⓖ Skal installeres på et ikke lett tilgjengelig sted. Ⓕ Må kun installeres uden for armenes rækkevidde. Ⓕ Instalovat pouze mimo dosah paží. Ⓔ Только для монтажа на расстоянии больше вытянутой руки. Ⓕ Csak kézzel elérhetetlen területre szerelhető. Ⓖ Instalować wyłącznie na odległość większą niż zasięg ramion. Ⓕ Ištaloval len na miesto mimo dosahu. Ⓕ Namestite izven dosega rok. Ⓕ Kolayca ulaşılamayacak bir yere kurulmalıdır. Ⓕ Installirati samo izvan dohvata ruke. Ⓕ A se instala doar in locuri fara acces. Ⓕ Може да се инсталира на места, където не може да се достигне. Ⓕ Väljasta installeerides käega puudutamise võimalus. Ⓕ Galima montuoti tik didesniu atstumu nei pasiekia ranka. Ⓕ Uzstādīt tikai ar roku nesasniedzamā attālumā. Ⓕ Treba da se instalīše samo van dohvata ruke. Ⓕ Тільки для монтажу поза межами досяжності. Ⓕ тек қол жетпейтін жерге орнатылуы керек.



+



Ⓓ Zur Verwendung in einer Umgebung, in der eine Ablagerung von leitfähigem Staub auf der Leuchte erwartet werden kann. Ⓔ For use in an environment in which a deposit of conductive dust on the luminaire may be expected. Ⓕ Destiné à être utilisé dans un environnement dans lequel il est possible que de la poussière conductrice s'accumule sur le luminaire. Ⓖ Da usare in ambienti in cui è possibile aspettarsi depositi di polvere conduttiva sull'impianto di illuminazione. Ⓖ Para aplicaciones en un entorno en el cual se puede esperar un depósito de polvo conductor encima de la luminaria. Ⓖ Para uso em ambiente, no qual pode ser esperada a acumulação de poeiras condutoras sobre a luminária. Ⓖ Για χρήση σε περιβάλλον στο οποίο αναμένεται απόθεση αγωγίμης σκόνης στο φωτιστικό. Ⓖ Voor gebruik in een omgeving, waar een ongebruikelijke stofafzetting op de armatuur kan worden verwacht. Ⓖ För användning i en miljö som där det kan förväntas en avlagring av damm på armaturen. Ⓖ Käytettäväksi ympäristöissä, joissa sähköä johtavia pölykertymiä voi olla odotettavissa lampulle. Ⓖ For bruk i et miljø der det forventes oppsamling av ledende støv på lampen. Ⓖ Til brug i miljøer, hvor der kan forventes aflejring af ledende støv på belysningsarmaturet. Ⓖ Pro použití v prostředí, kde lze očekávat usazování vodivého prachu na svítidle. Ⓖ Для использования в местах, где возможно оседание на светильнике электропроводящей пыли. Ⓖ Olyan környezetben használandó, ahol elektromosságot vezető por rakodhat a világítótestre. Ⓖ Do użytku w środowisku, w którym można spodziewać się gromadzenia na oprawie kurzu (pyłu) przewodzącego prąd. Ⓖ Na použití v prostředí, v ktorom možno očakávať usadzovanie vodivého prachu na svietidle. Ⓖ Za uporabo v okolju, kjer se lahko pričakuje kopičenje prevodnega prahu na svetilu. Ⓖ Lamba üzərində iletken toz birikmesinin beklenebileceği bir ortamda kullanım içindir. Ⓖ Za uporabu u okolini, u kojoj se mogu očekivati naslage vodne prašine na svjetiljci. Ⓖ Pentru utilizare într-un mediu în care un depozit de praful conductiv poate fi de aşteptat pe lampă. Ⓖ Предназначени за среда, в която е възможно натрупване на проводящ прах върху осветителното тяло. Ⓖ Kasutamiseks keskkonnas, kus võib tolmü oodata. Ⓖ Skirta naudoti aplinkoje, kurioje gali kauptis laidžios dulkes ant šviestuvo. Ⓖ Izmantošanai vidē, kurā var būt paredzama strāvu vadošu putekļu uzkrāšanās uz spuldzes virsmas. Ⓖ Za upotrebu u okruženju gde se očekuje depozit provodne prašine na lampi. Ⓖ Для використання в середовищі, в якому може очікуватись нашарування струмопровідного пилу на світильник. Ⓖ Шамшырақта электрлік -статикалық шаңның жиналуы мүмкін сыртқы ортада қолдану үшін.

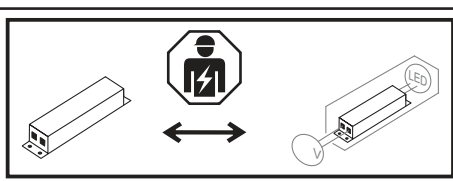
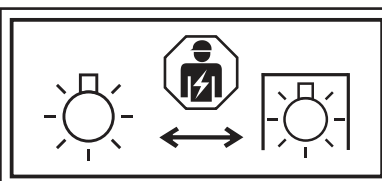

Ⓓ Die in dieser Leuchte enthaltene Lichtquelle und das Betriebsgerät dürfen nur durch den Hersteller, seinem Kundendienst oder einer ähnlich qualifizierten Person ausgetauscht werden. Ⓔ The light source and the controlgear contained in this luminaire shall only be replaced by the manufacturer or their service agent or a skilled qualified person.

Ⓕ La source lumineuse et l'appareil de commande contenus dans ce luminaire ne peuvent être remplacés que par le fabricant, son service après-vente ou une personne qualifiée. Ⓖ La sorgente luminosa e l'alimentatore contenuti in questo apparecchio possono essere sostituiti solo dal costruttore, dal suo centro di assistenza o da personale qualificato. Ⓖ La fuente de luz y el equipo de control contenidos en esta luminaria solo deben ser reemplazados por el fabricante, su servicio técnico o una persona cualificada. Ⓖ A fonte de luz e o equipamento de controlo contidos nesta luminária só podem ser substituídos pelo fabricante, pelo seu serviço autorizado ou por pessoa qualificada. Ⓖ Η πηγή φωτός και το σύστημα ελέγχου που περιέχονται σε αυτό το φωτιστικό μπορούν να αντικατασταθούν μόνο από τον κατασκευαστή, τον εξουσιοδοτημένο τεχνικό του ή από κατάλληλα εκπαιδευμένο άτομο. Ⓖ De lichtbron en het voorschakelapparaat in dit armatuur mogen uitsluitend worden vervangen door de fabrikant, diens servicepartner of een vakbekwaam persoon. Ⓖ Ljuskällan och driftdonet i denna armatur får endast bytas av tillverkaren, dess servicepartner eller en fackkunnig person. Ⓖ Tämän valaisimen valonlähteen ja liitäntälaitteen saa vaihtaa vain valmistaja, sen huolto tai pätevä henkilö. Ⓖ Lyskilden og forkoblingen i denne armaturen skal kun skiftes af producenten, hans servicepartner eller en kvalificeret person. Ⓖ Lyskilden og forkoblingen i dette armatur må kun udskiftes af producenten, dennes servicepartner eller en kvalificeret person. Ⓖ Světelný zdroj a předradník v tomto svítidle smí vyměnit pouze výrobce, jeho servis nebo kvalifikovaná osoba. Ⓖ Источник света и пускорегулирующую аппаратуру в данном светильнике могут заменять только производитель, его сервисная служба или квалифицированное лицо. Ⓖ A világítótestben lévő fényforrást és előtétet csak a gyártó, annak szervize vagy képzett személy cserélheti. Ⓖ Źródło światła i zasilacz znajdujące się w tej oprawie mogą być wymieniane wyłącznie przez producenta, jego serwis lub osobę wykwalifikowaną. Ⓖ Svetelný zdroj a predradník v tomto svietidle smie vymieňať len výrobca, jeho servis alebo kvalifikovaná osoba. Ⓖ Svetlobni vir in napajalnik v tej svetilki lahko zamenja le proizvajalec, njegov servis ali usposobljena oseba. Ⓖ Bu armatürdeki ışık kaynağı ve kontrol donanımı yalnızca üretici, yetkili servisi veya yetkin bir kişi tarafından değiştirilebilir. Ⓖ Izvor svetla i upravljački uređaj u ovoj svjetiljci smiju zamjenjivati samo proizvođač, njegov servis ili kvalificirana osoba. Ⓖ Sursa de lumină și balastul conținute în acest corp de iluminat pot fi înlocuite doar de producător, de serviciul său autorizat sau de o persoană calificată. Ⓖ Светлинният източник и апаратът в това осветително тяло могат да се подменят само от производителя, неговия сервис или квалифицирано лице. Ⓖ Selles valgustus oleval valgusallikal ja toiteplokkil võib vahetada ainult tootja, tema hoolduspartner või kvalifitseeritud isik. Ⓖ Šiame šviestuve esantį šviesos šaltinį ir maitinimo įrenginį gali keisti tik gamintojas, jo servisas arba kvalifikuotas asmuo. Ⓖ Šā gaismekļa gaismas avotu i vadības ierīci drīkst nomainīt tikai ražotājs, viņa serviss vai kvalificēta persona. Ⓖ Izvor svetlosti i upravljački uređaj u ovoj svetiljci smeju da zamene samo proizvođač, njegov servis ili kvalifikovano lice. Ⓖ Джерело світла та пускорегулювальний апарат у цьому світильнику можуть замінювати лише виробник, його сервіс або кваліфікована особа. Ⓖ Осы шамдағы жарық көзін және басқару құрылғысын тек өндіруші, оның сервистік өкілі немесе білікті адам ғана ауыстыра алады.



5MA75-261673_al
22.04.2026 / KIN

Siteco GmbH
Georg-Simon-Ohm-Straße 50
83301 Traunreut, Germany
mail: technicalsupport@siteco.de
Phone: +49 8669 / 33-844
www.siteco.com