

# Streetlight SL 31 midi

NEMA

5XH3...

5XH7...

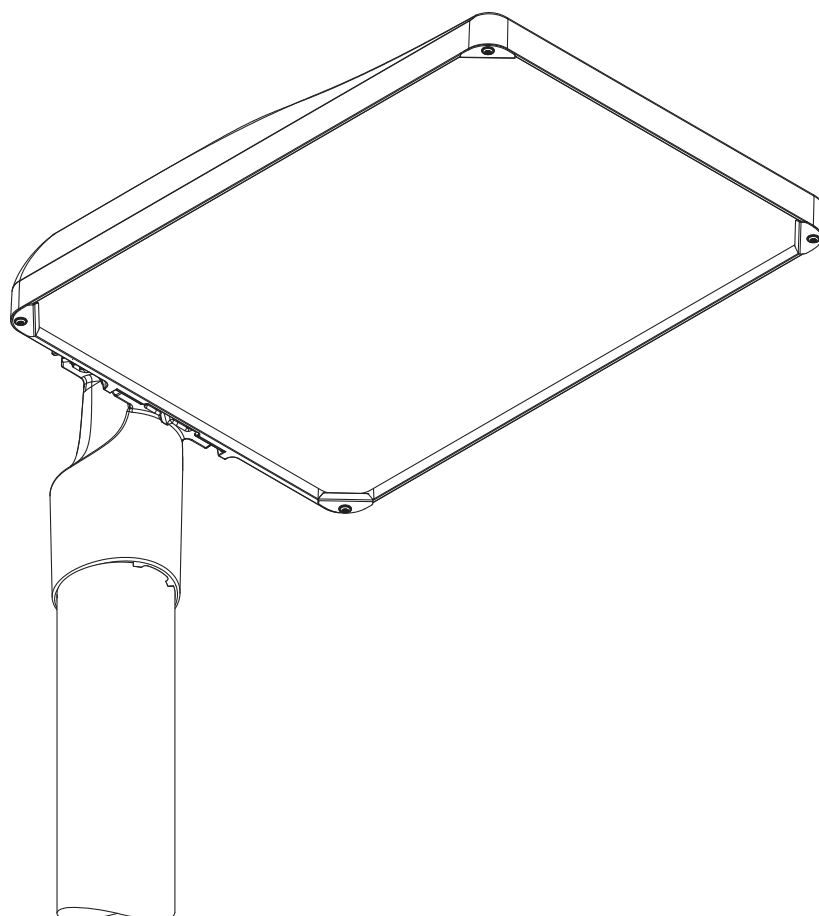

**siteco**

Streetlight SL 31 midi - NEMA

[ mm ]

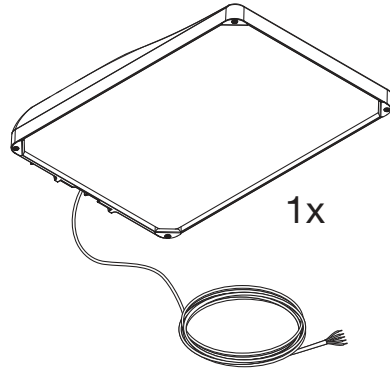

1x

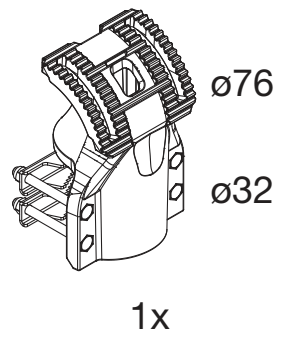
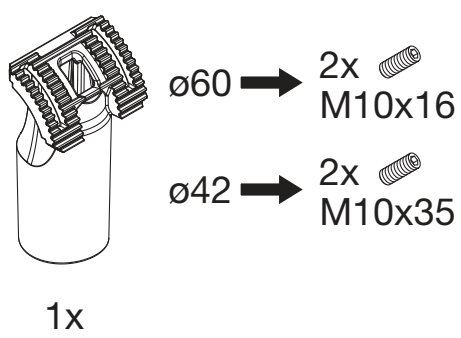
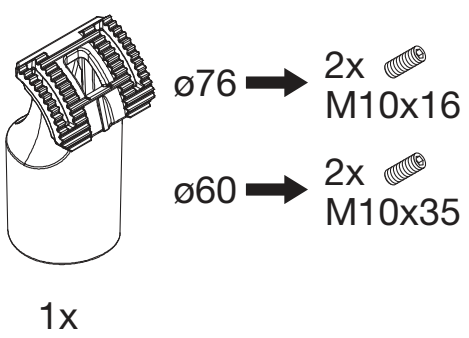
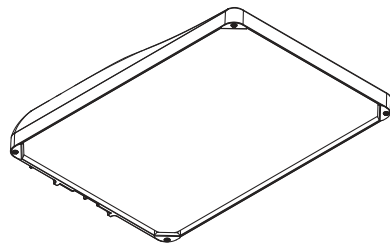
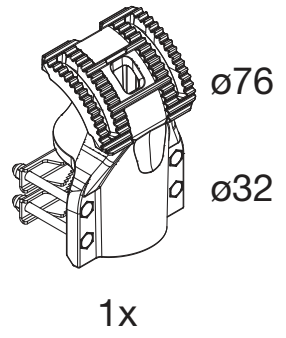
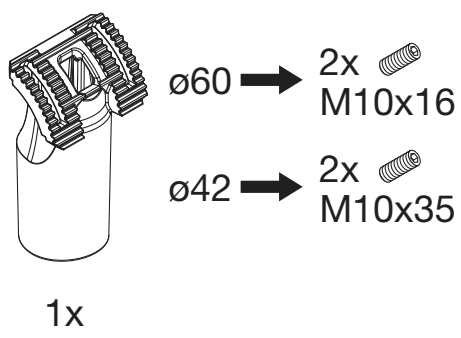
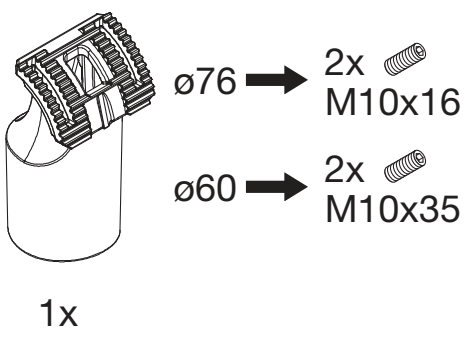

	RFID
Frequency	868 MHz
≤ HF-Power	0 mW



[www.siteco.de/iq/iqapp](http://www.siteco.de/iq/iqapp)

Streetlight SL 31 midi - NEMA

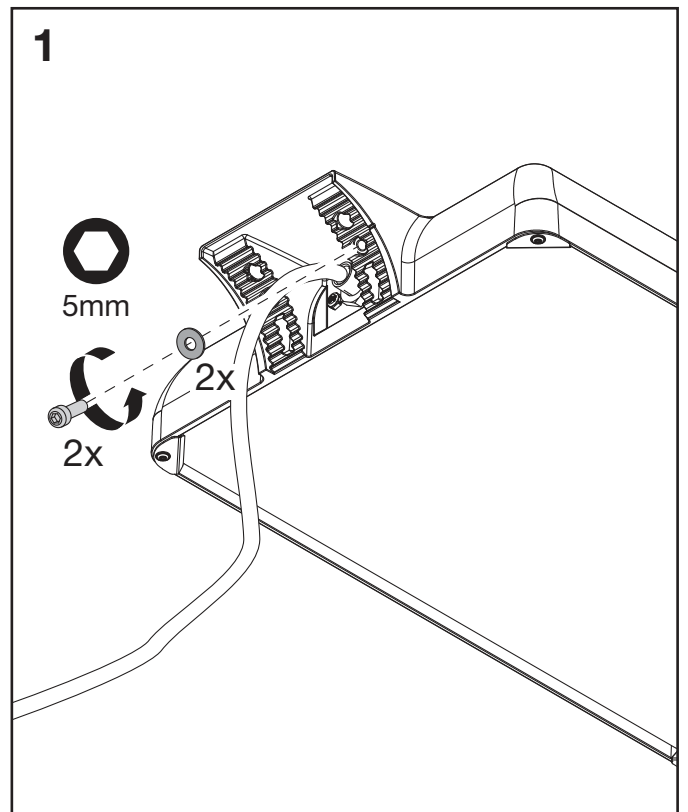
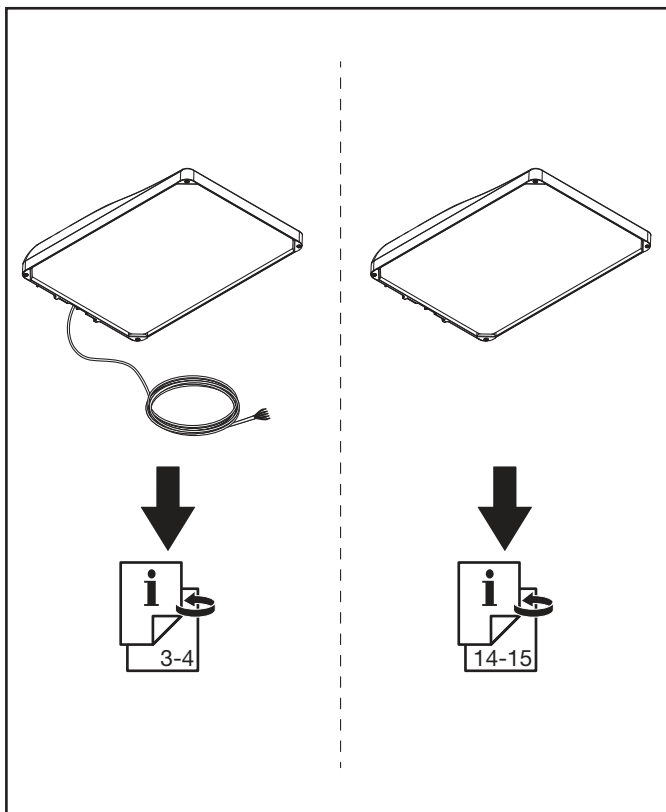
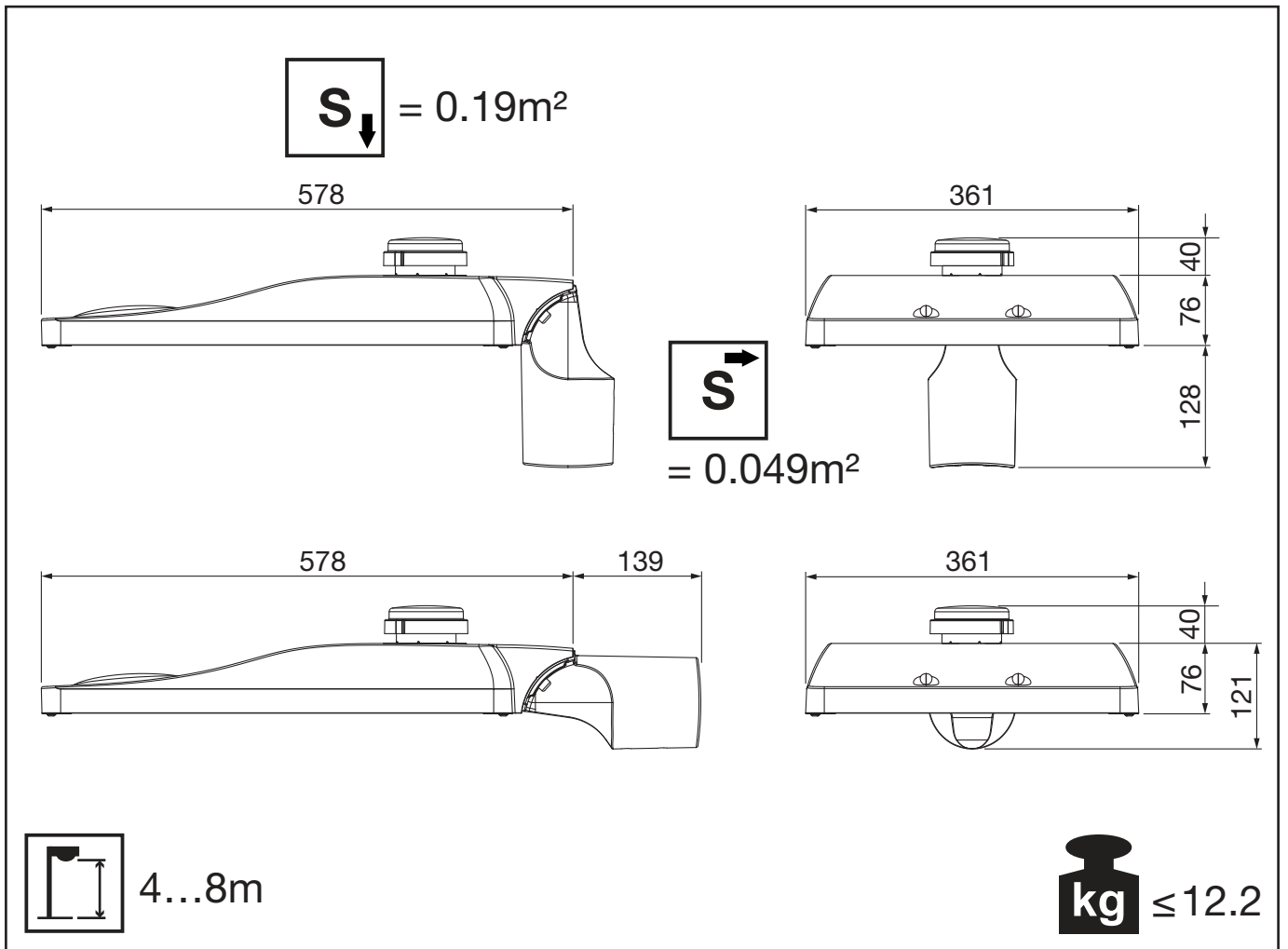

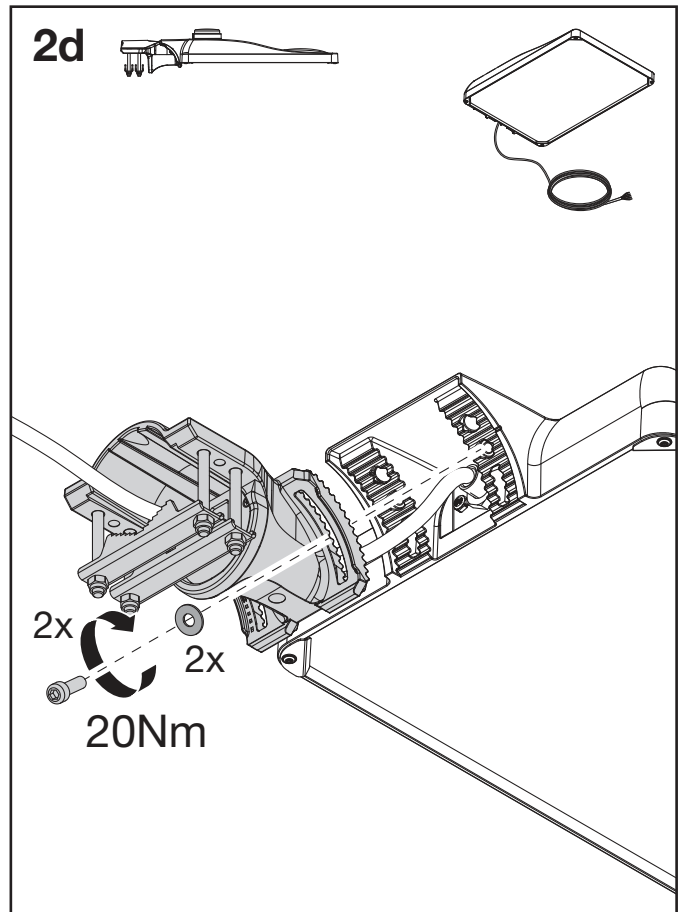
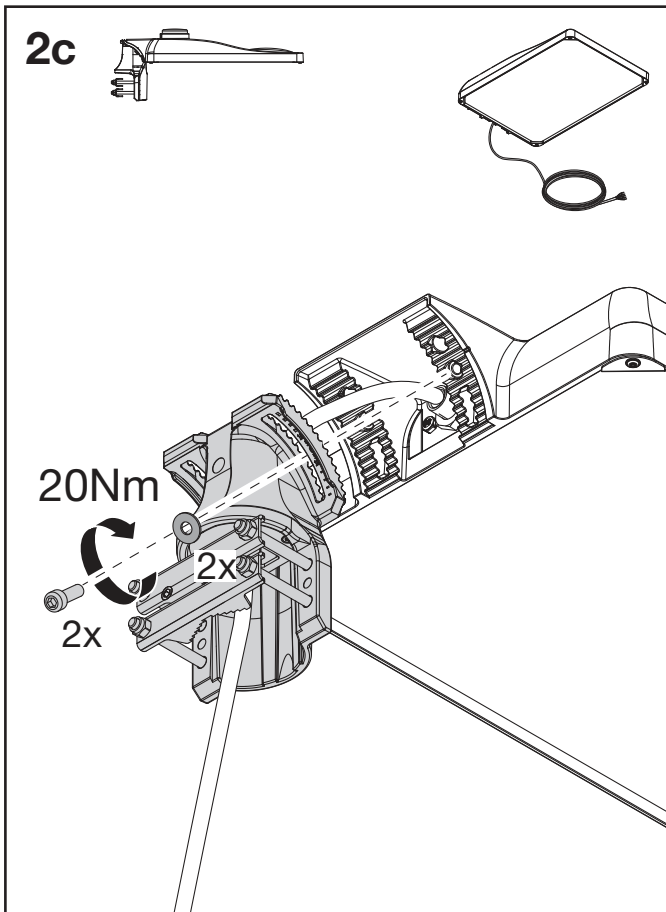
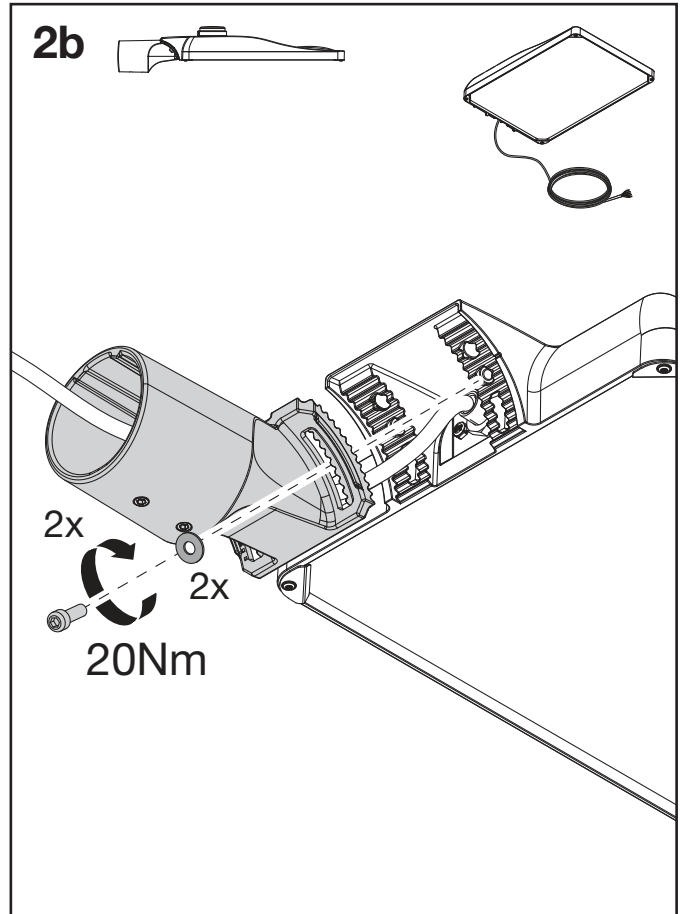
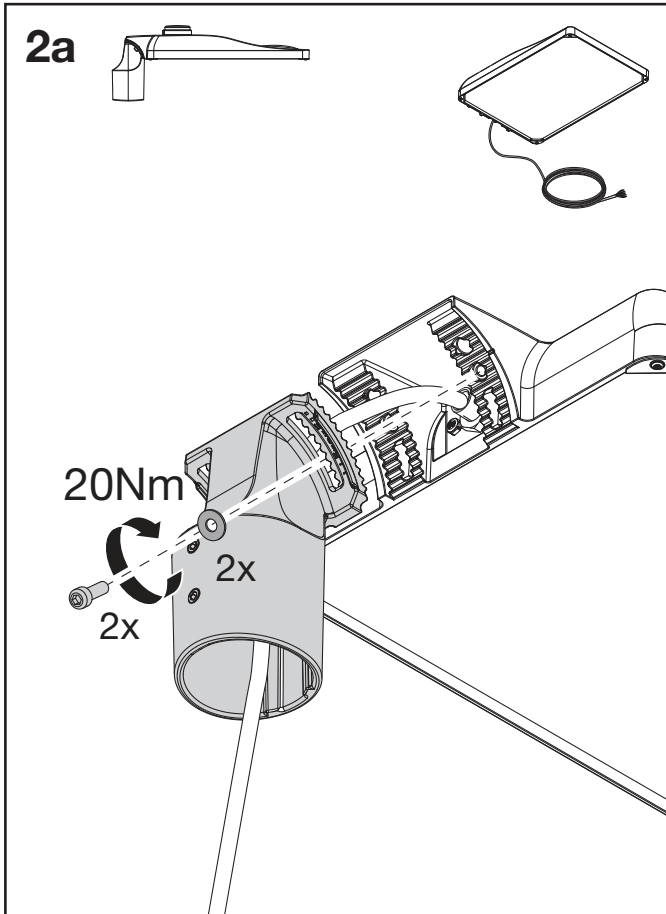

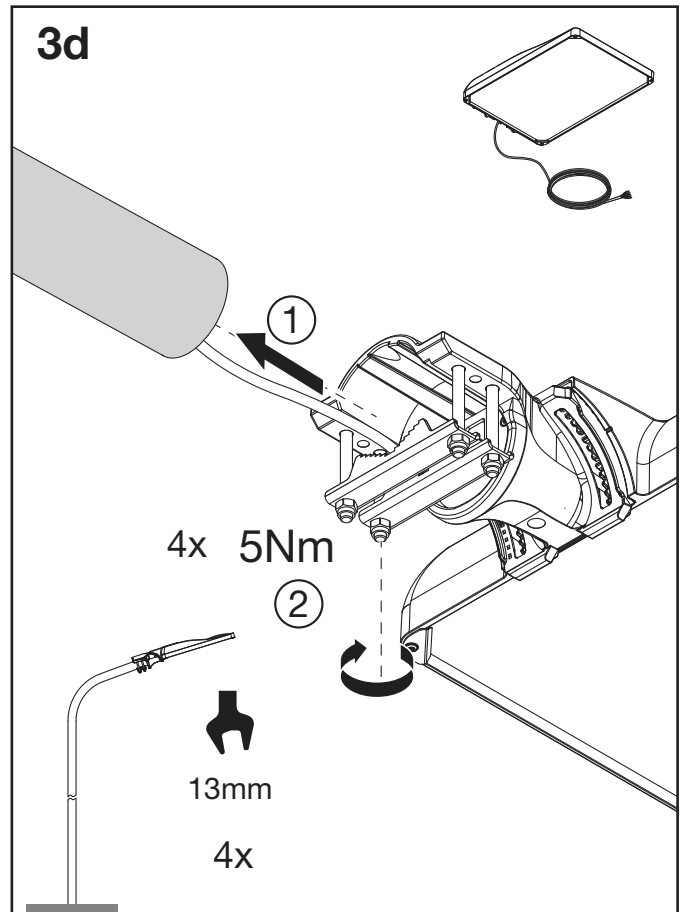
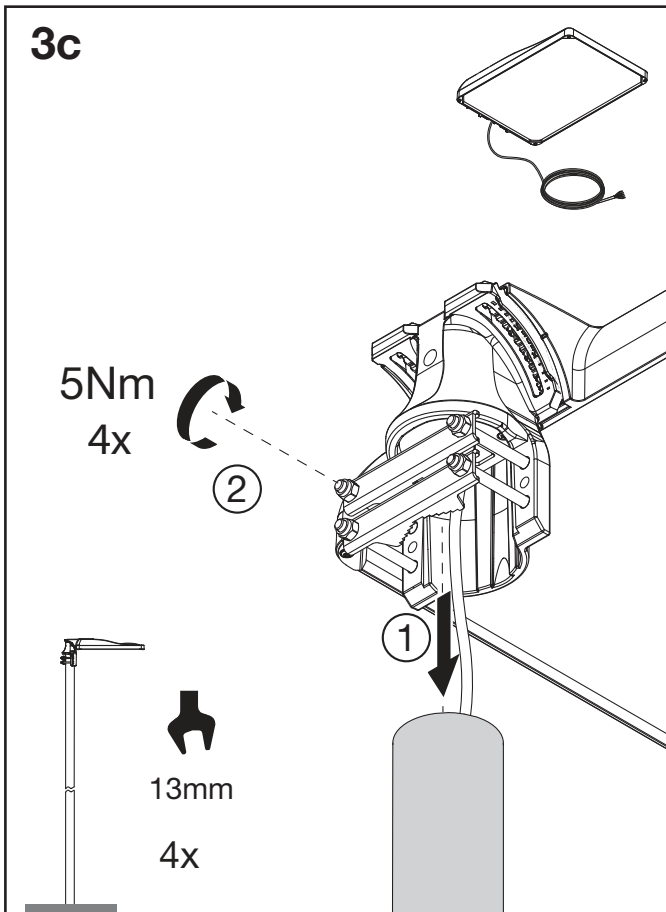
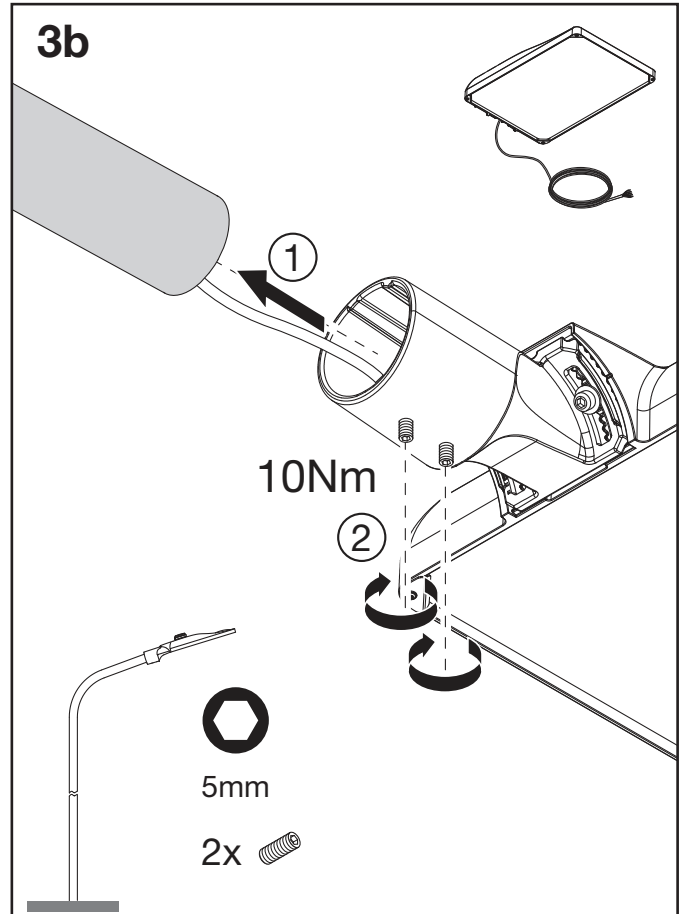
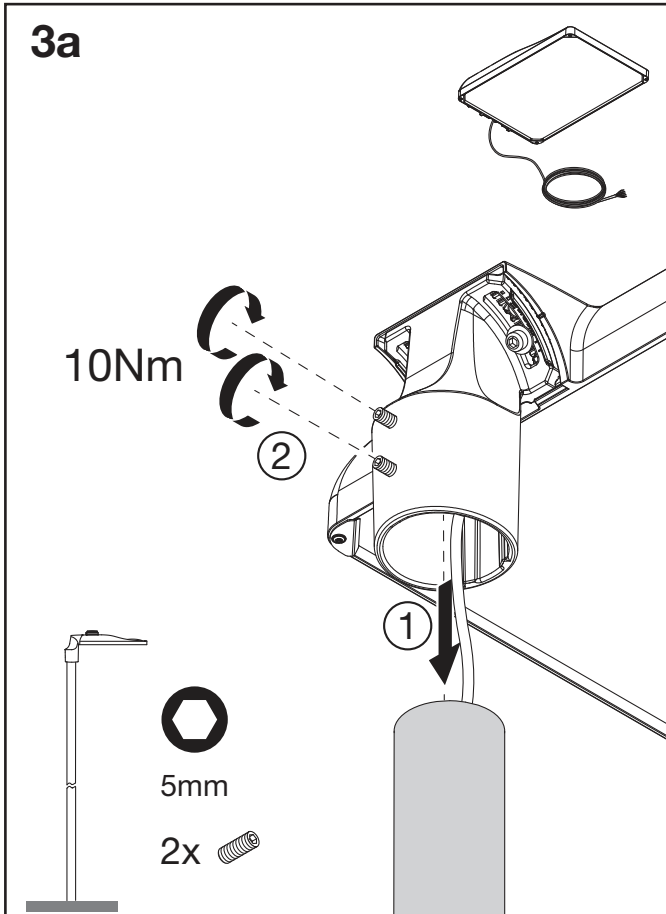

Streetlight SL 31 midi - NEMA

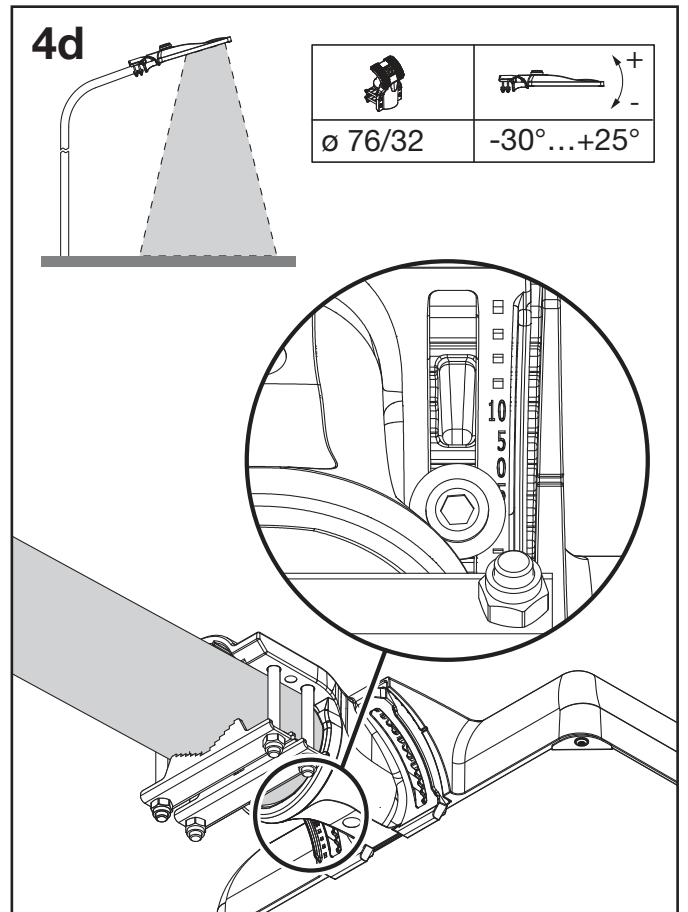
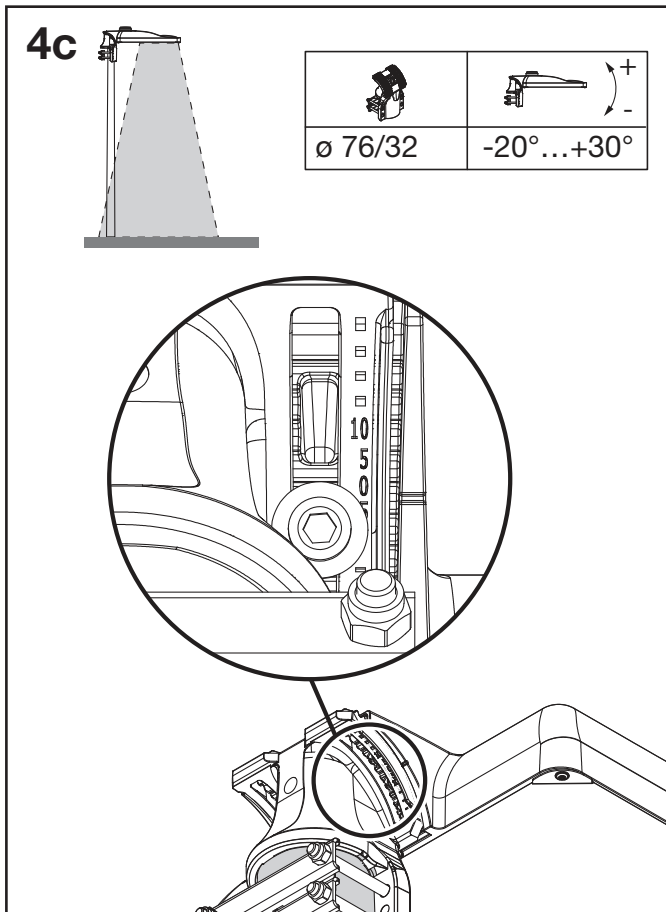
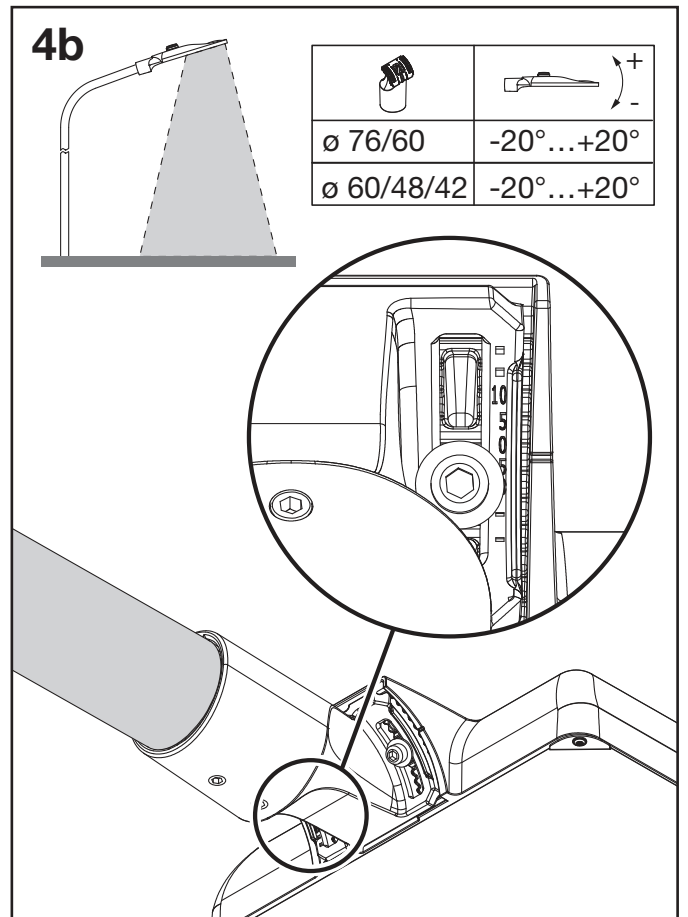
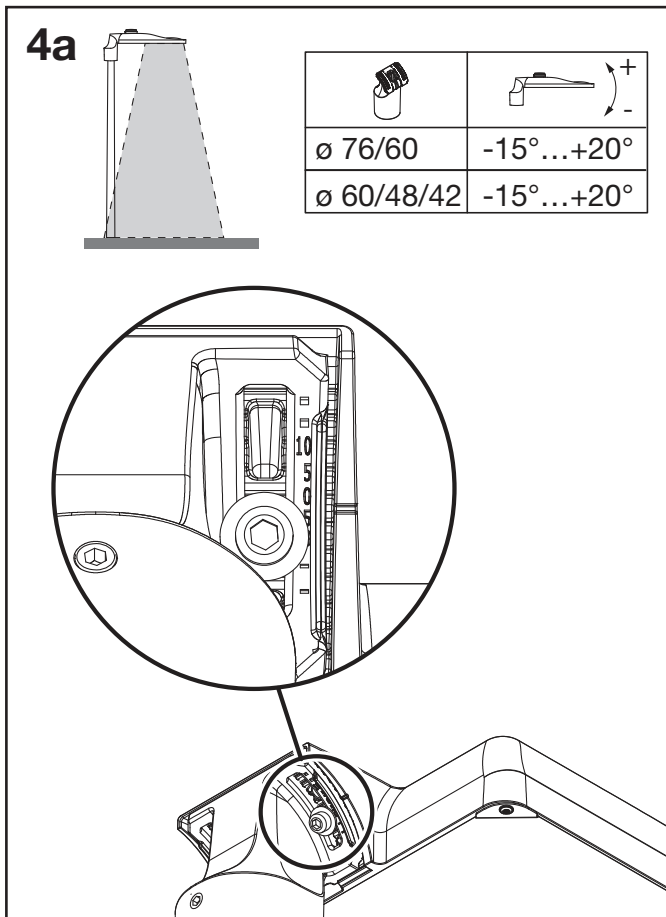

# Streetlight SL 31 midi - NEMA

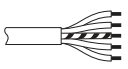
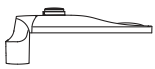
			L	N	PE
NEMA 7pin SK1	3	5XH3/7 ... N...	x	x	x
NEMA 7pin + Smart Interface SK1	3	5XH3/7 ... M...	x	x	x

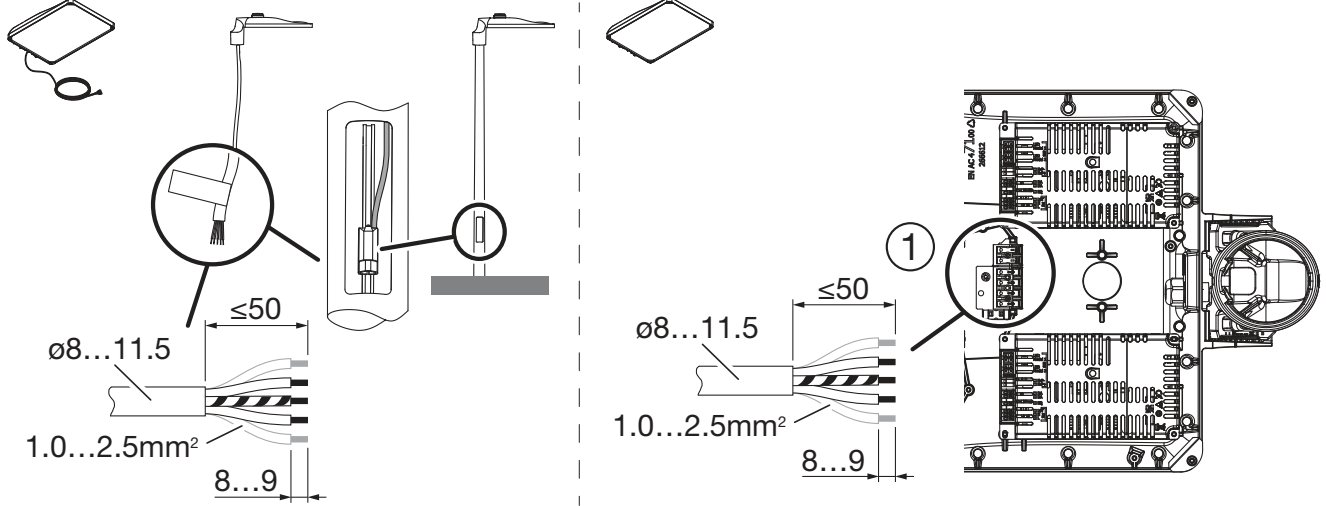
5XH3F...  
5XH7F...

5XH3G...  
5XH7G...

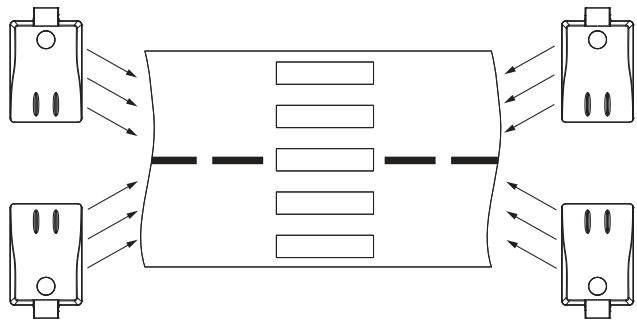

5XH3G...  
5XH7G...

5XH3F...  
5XH7F...

**LumIdent:**

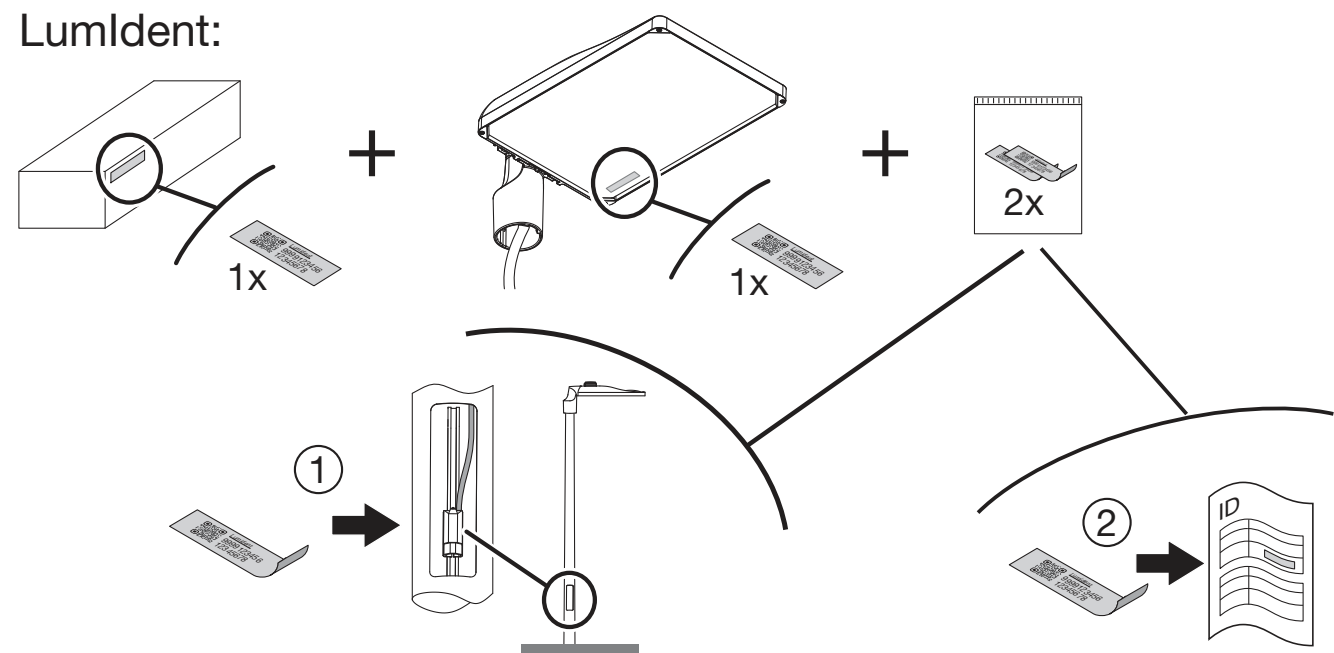



**NEMA**



IP66

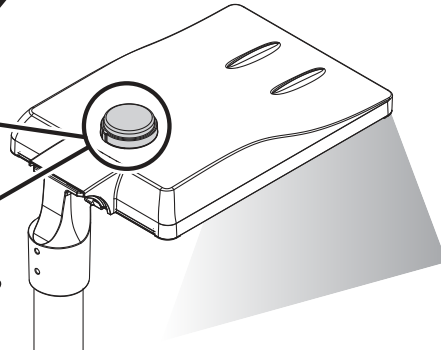
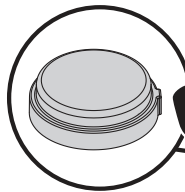

IP20

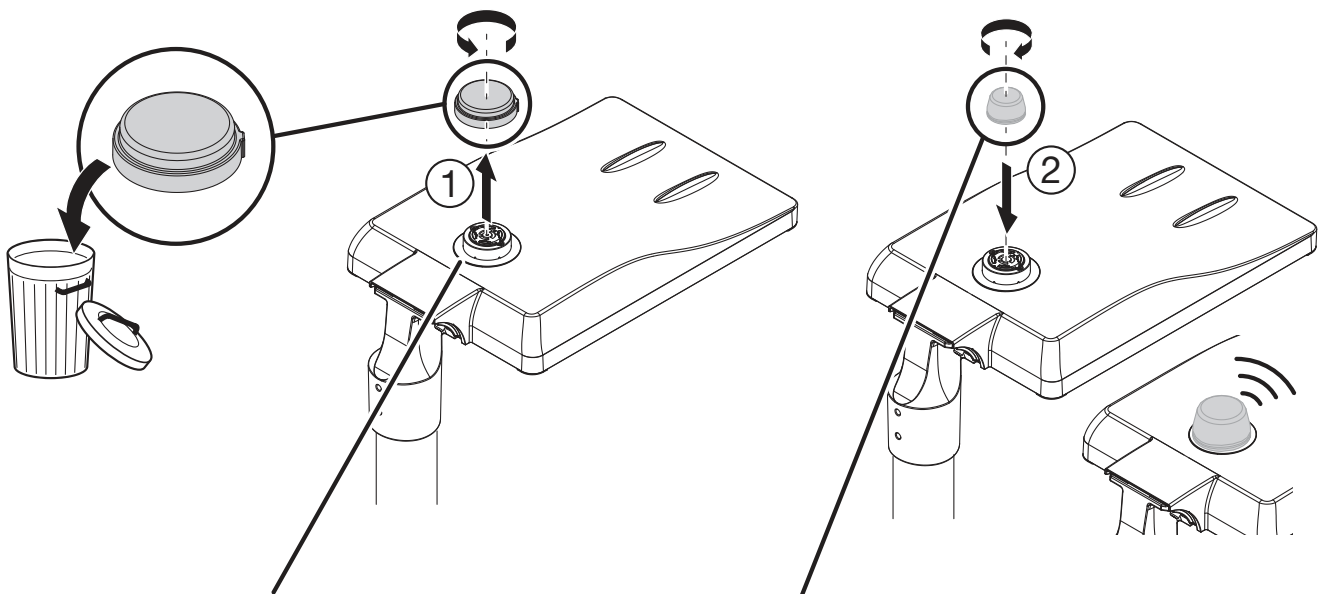
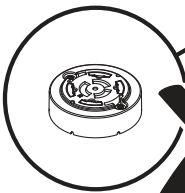

	Strom / Current (A)	Spannung / Voltage (V)
Powerkontakte / Power contacts	max. 1.5A	240V AC
Signalkontakte / Signal contacts	max. 1.5A	30V DC

**kg** ≤ 0.15

IP66



### Smart interface

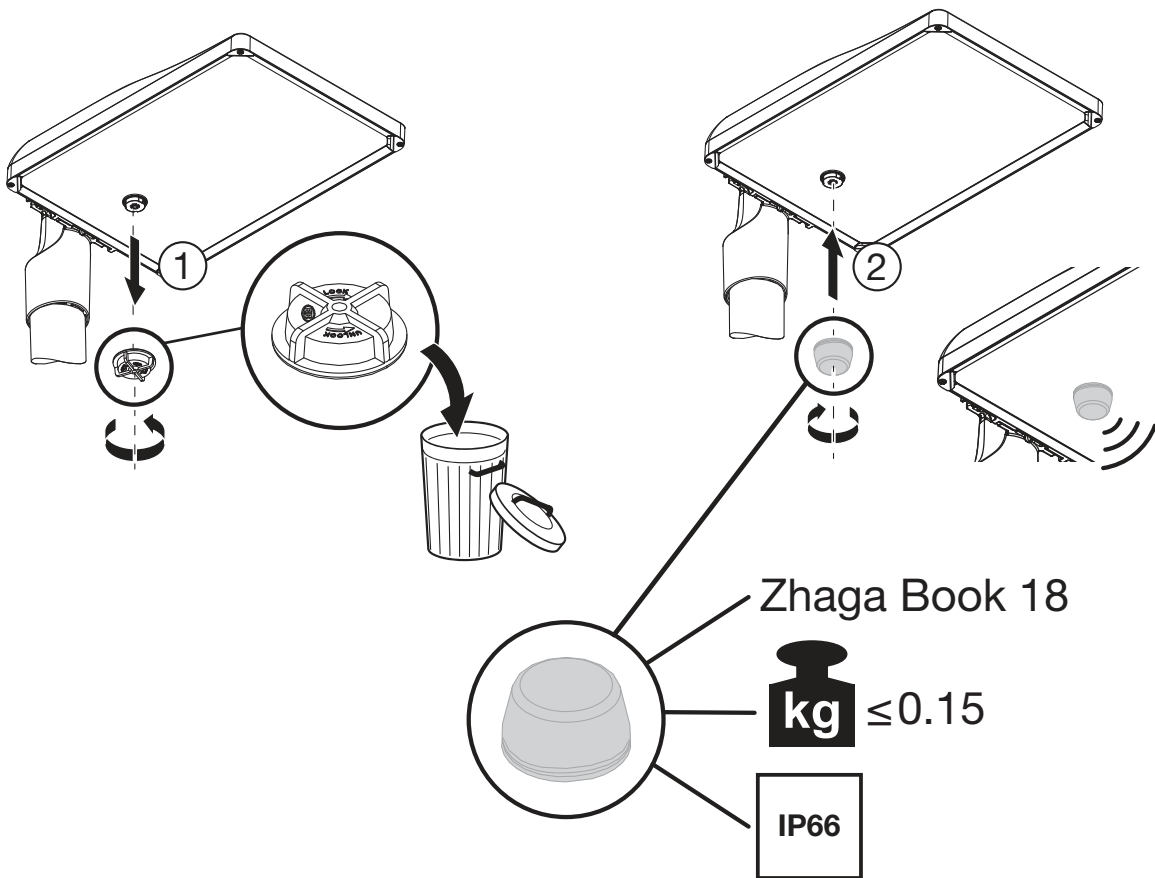
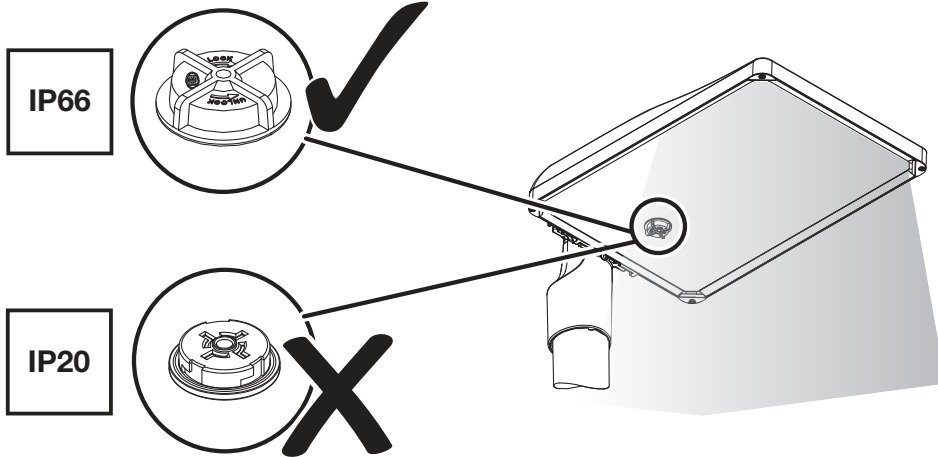

5XH3...

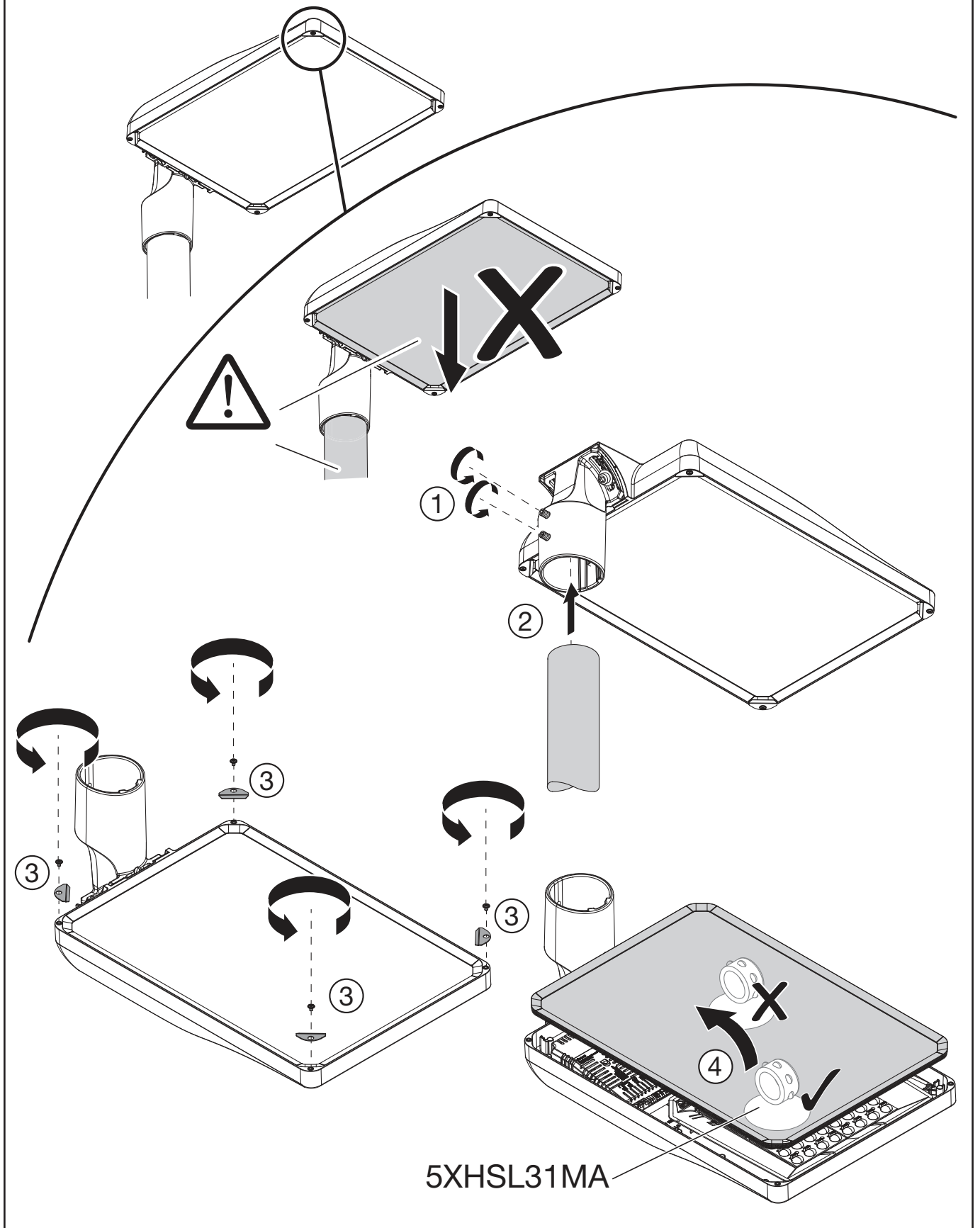

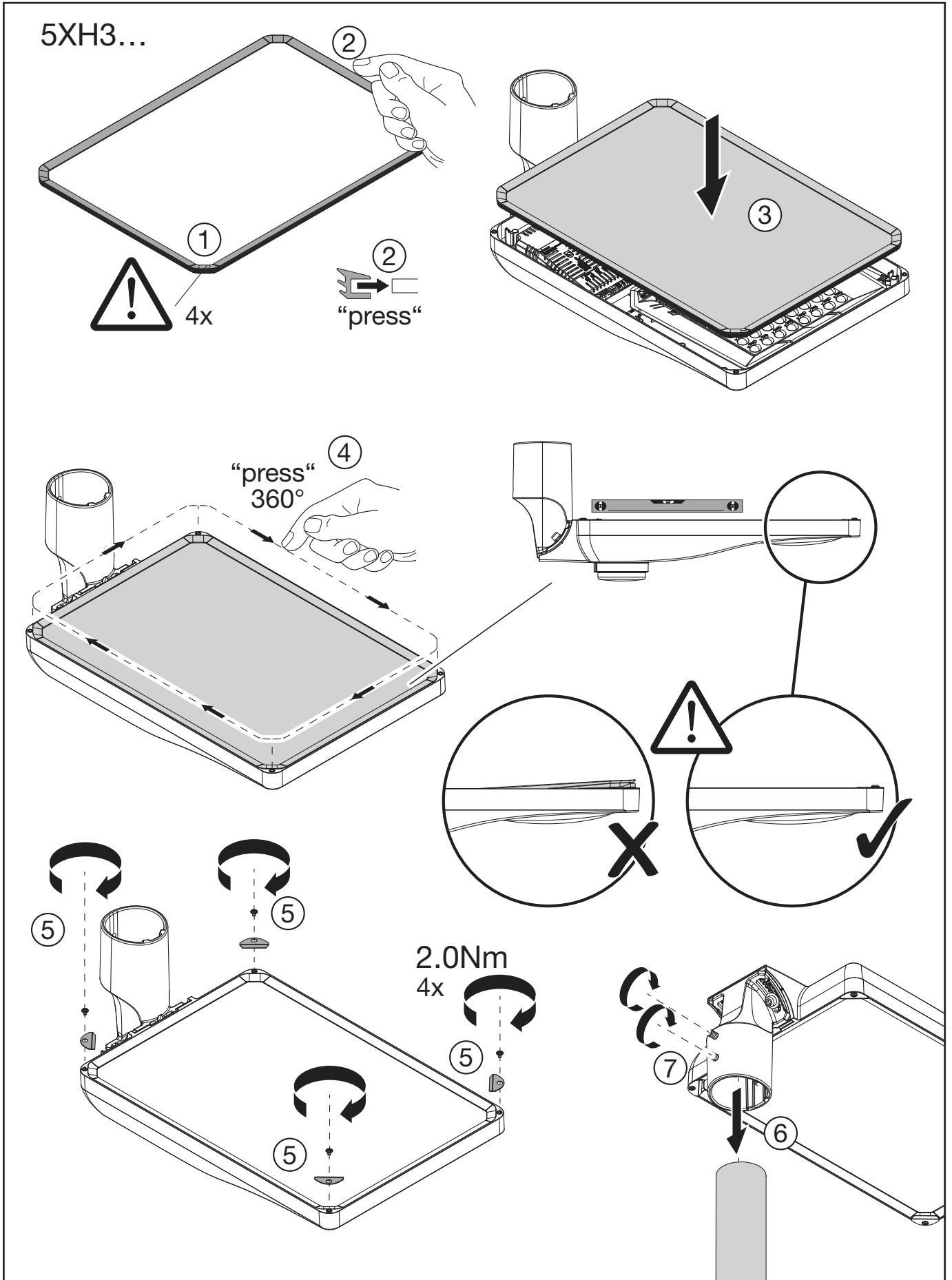

# Streetlight SL 31 midi - NEMA

Die Lichtquelle sowie das Betriebsgerät entsprechen den Anforderungen der Ökodesign-Verordnung (EU) 2019/2020, diese sind gemäß dieser Verordnung austauschbar.  
The light source and control gear comply with the requirements of the Ecodesign Regulation (EU) 2019/2020 and are interchangeable in accordance with this regulation.

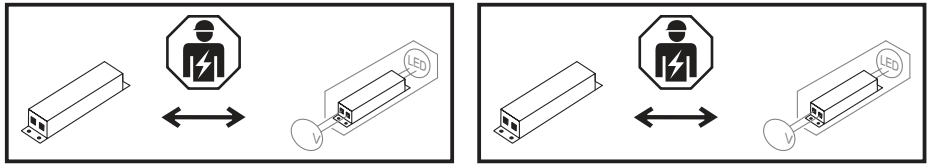

5XH7...

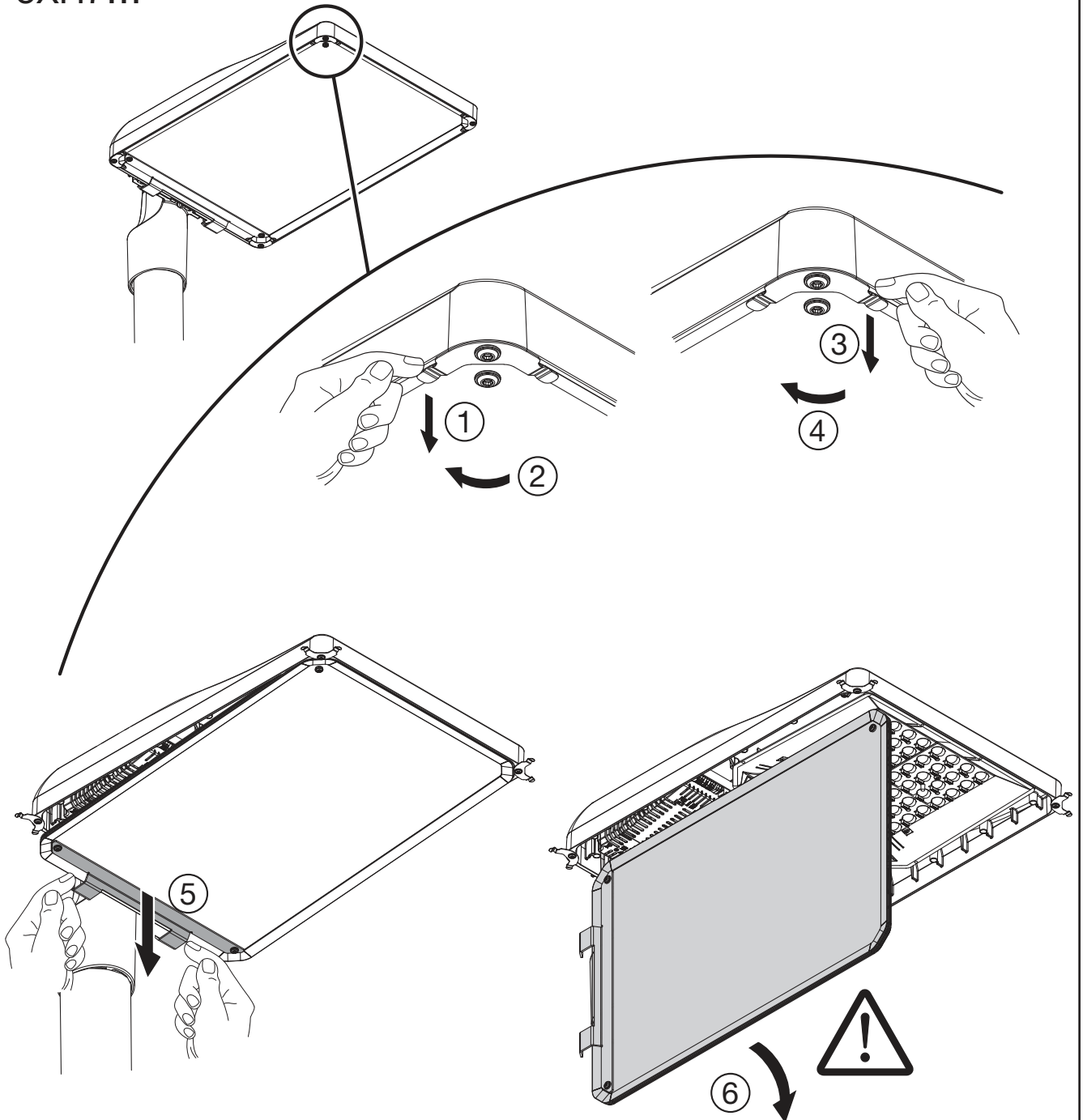

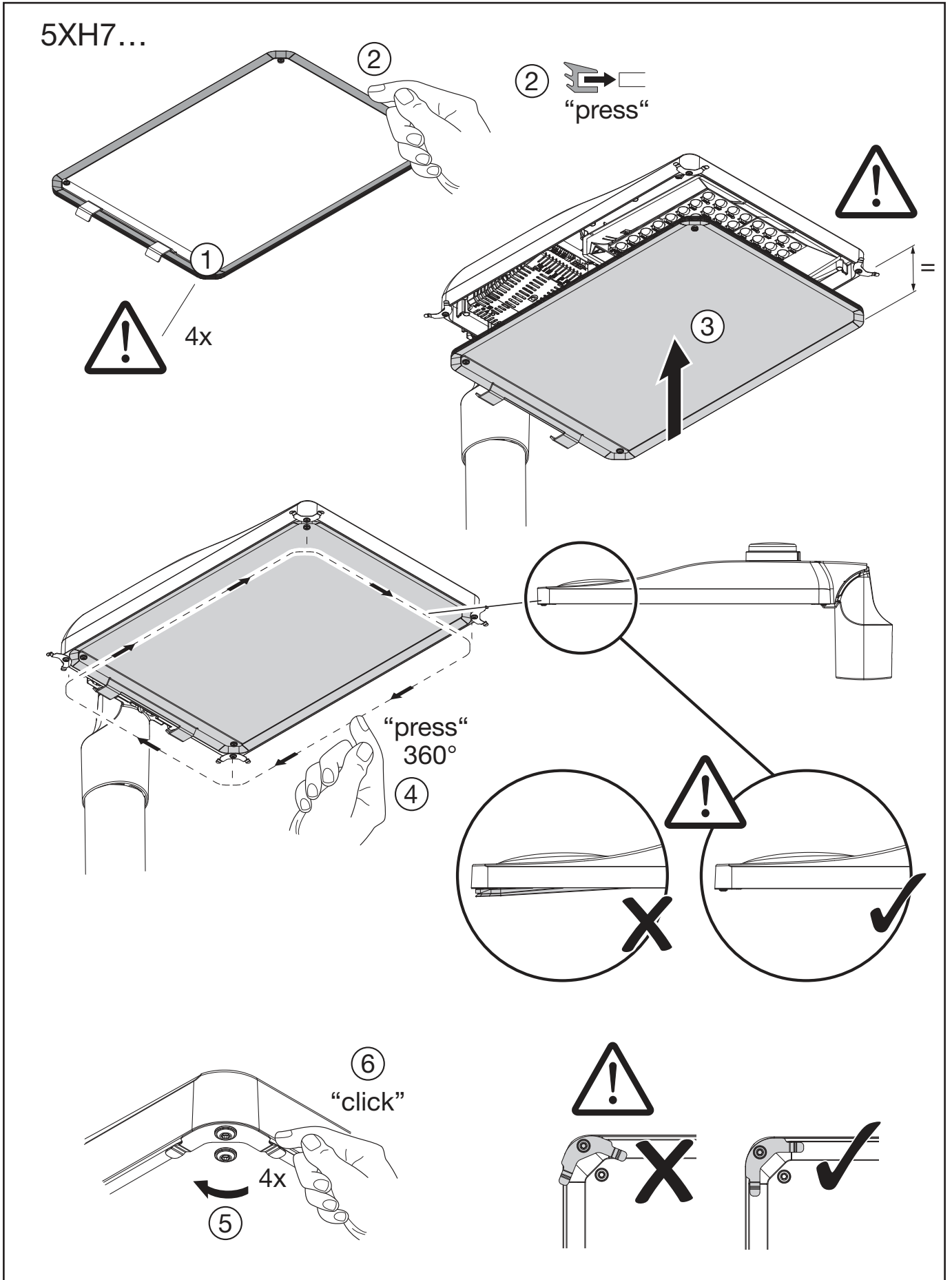

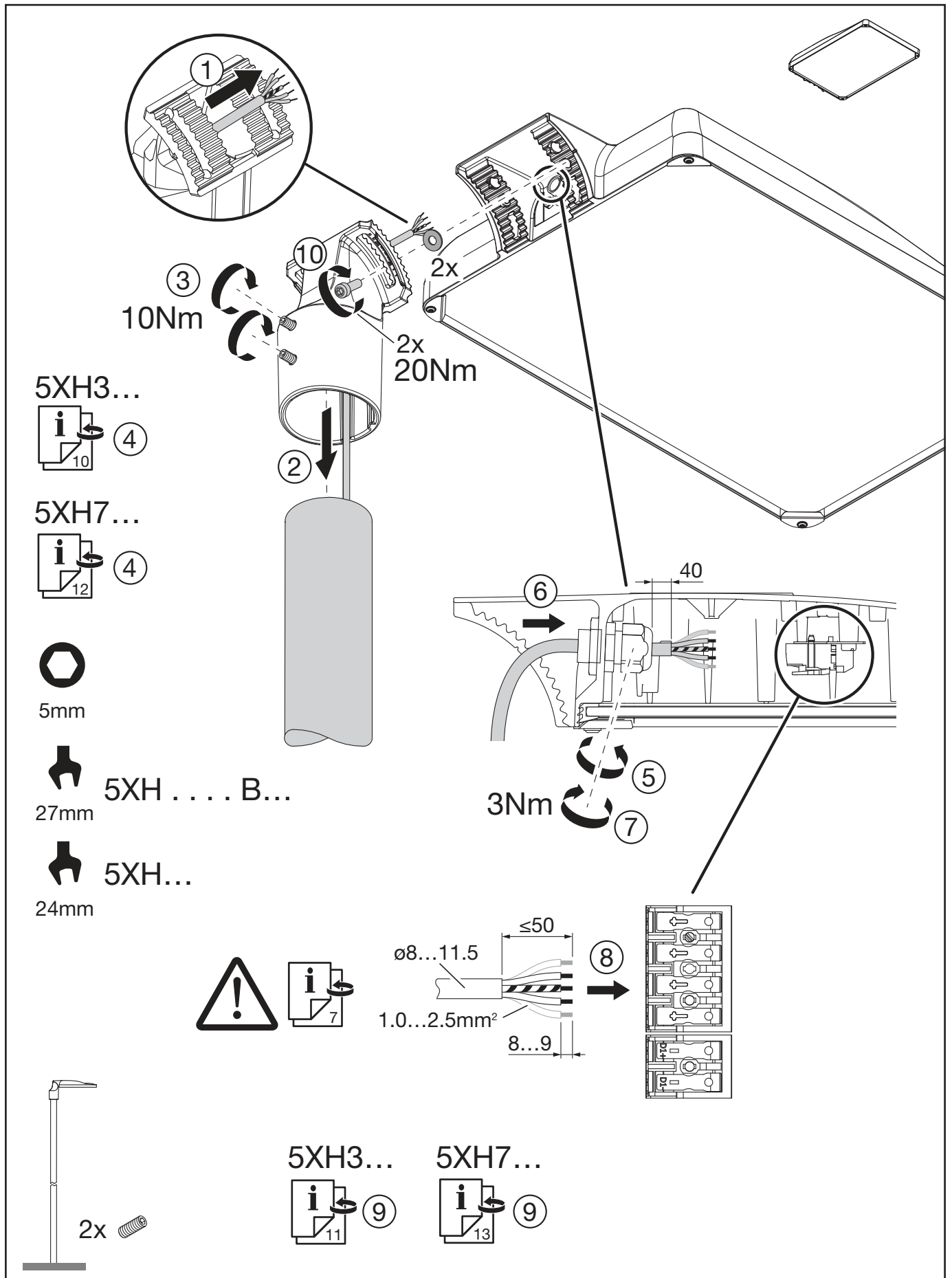

Streetlight SL 31 midi - NEMA

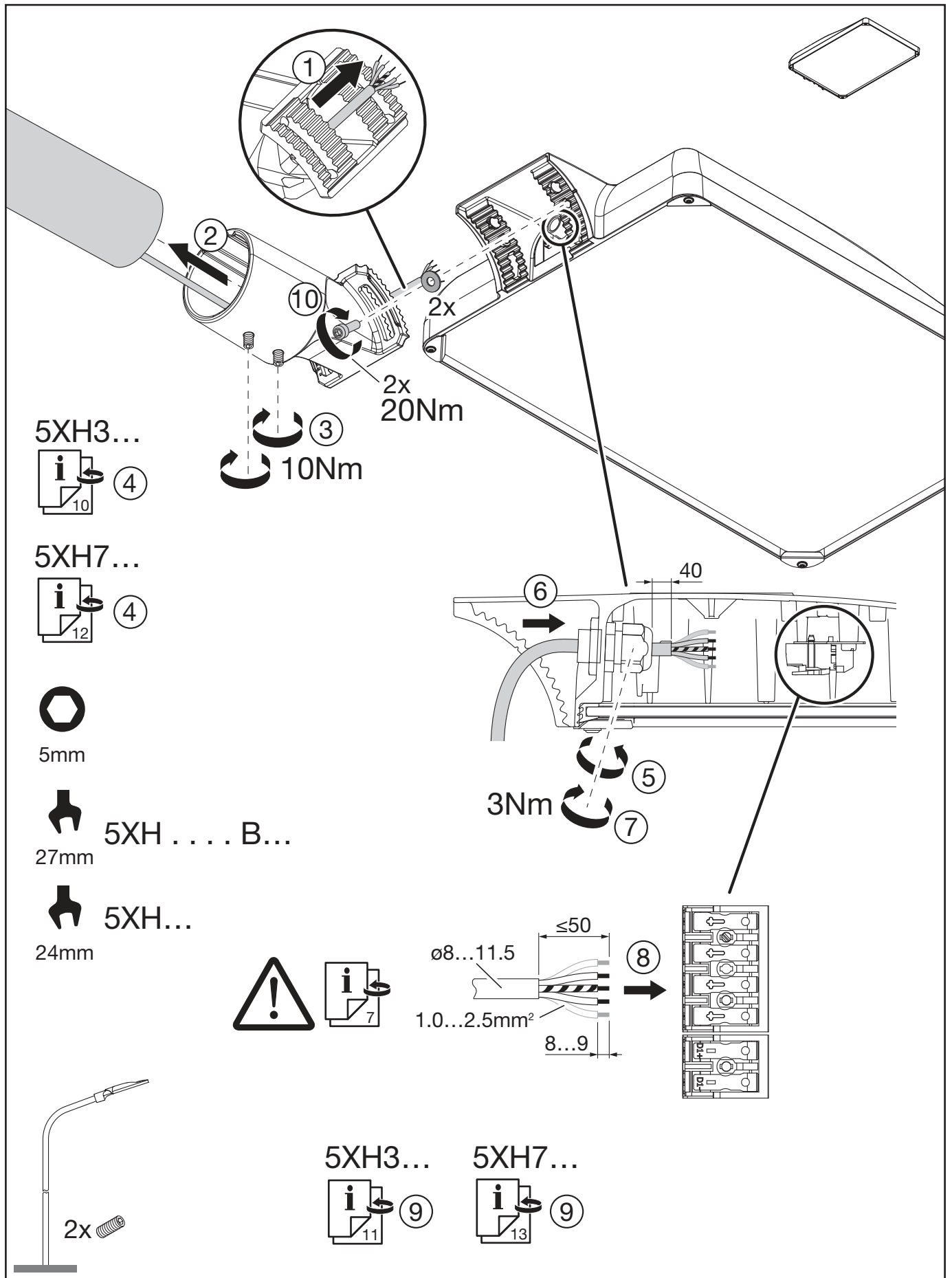

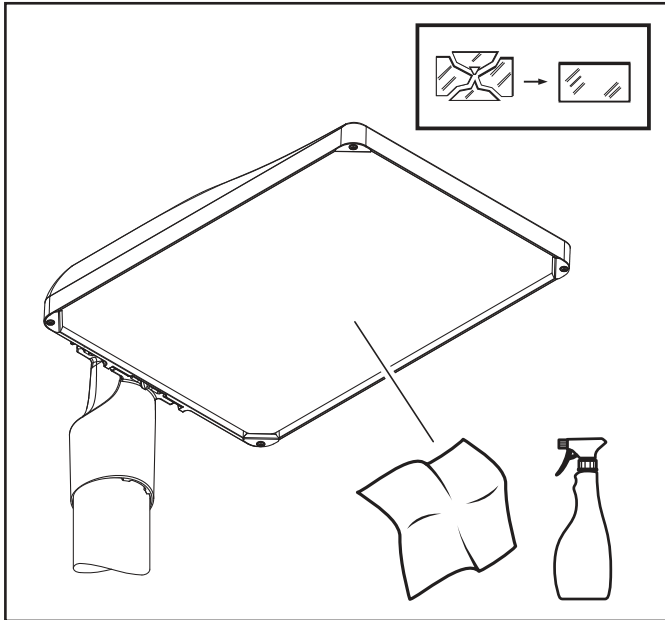

	Energy Efficiency Class
5XH3 . 3...	D
5XH3 . 4...	D
5XH3 . 5...	E
5XH3 . 6...	D
5XH3 . 7...	E
5XH7 . 3...	D
5XH7 . 4...	D
5XH7 . 5...	E
5XH7 . 6...	D
5XH7 . 7...	E

Dieses Produkt enthält eine Lichtquelle der Energieeffizienzklasse D oder E.  
This product contains a light source of energy efficiency class D or E.

Ⓣ Hiermit erklärt die Siteco GmbH, dass der Funkanlagentyp der Richtlinie 2014/53/EU entspricht. Der vollständige Text der EU-Konformitätserklärung ist unter der folgenden Internetadresse verfügbar: <https://www.siteco.de/red-konformitaetserklaerung>  
 Ⓢ Hereby, Siteco GmbH declares that the radio equipment type is in compliance with Directive 2014/53/EU. The full text of the EU declaration of conformity is available at the following internet address: <https://www.siteco.com/red-conformity>

Ⓣ Die in dieser Leuchte enthaltene Lichtquelle und das Betriebsgerät dürfen nur durch den Hersteller, seinem Kundendienst oder einer ähnlich qualifizierten Person ausgewechselt werden. Ⓢ The light source and the control gear contained in this luminaire shall only be replaced by the manufacturer or their service agent or a skilled qualified person.

Ⓣ La source lumineuse et l'appareil de commande contenus dans ce luminaire ne peuvent être remplacés que par le fabricant, son service après-vente ou une personne qualifiée. Ⓡ La sorgente luminosa e l'alimentatore contenuti in questo apparecchio possono essere sostituiti solo dal costruttore, dal suo centro di assistenza o da personale qualificato. Ⓝ La fuente de luz y el equipo de control contenidos en esta luminaria solo deben ser reemplazados por el fabricante, su servicio técnico o una persona cualificada. Ⓢ A fonte de luz e o equipamento de controlo contidos nesta luminária só podem ser substituídos pelo fabricante, pelo seu serviço autorizado ou por pessoa qualificada. Ⓢ Η πηγή φωτός και το σύστημα ελέγχου που περιέχονται σε αυτό το φωτιστικό μπορούν να αντικατασταθούν μόνο από τον κατασκευαστή, τον εξουσιοδοτημένο τεχνικό του ή από κατάλληλα εκπαιδευμένο άτομο. Ⓢ De lichtbron en het voorschakelapparaat in dit armatuur mogen uitsluitend worden vervangen door de fabrikant, diens servicepartner of een vakbekwaam persoon. Ⓢ Ljuskällan och driftdonet i denna armatur får endast bytas av tillverkaren, dess servicepartner eller en fackkunnig person. Ⓢ Tämän valaisimen valonlähteen ja liitäntälaitteen saa vaihtaa vain valmistaja, sen huolto tai pätevä henkilö. Ⓢ Lyskilden og forkoblingen i denne armaturen skal kun skiftes av produsenten, hans servicepartner eller en kvalifisert person. Ⓢ Lyskilden og forkoblingen i dette armatur må kun udskiftes af producenten, dennes servicepartner eller en kvalificeret person. Ⓢ Světelný zdroj a předřadník v tomto svítidle smí vyměnit pouze výrobce, jeho servis nebo kvalifikovaná osoba. Ⓢ Источник света и пускорегулирующую аппаратуру в данном светильнике могут заменять только производитель, его сервисная служба или квалифицированное лицо. Ⓢ A világítóttestben lévő fényforrás és előtétet csak a gyártó, annak szervize vagy képzett személy cserélheti. Ⓢ Źródło światła i zasilacz znajdujące się w tej oprawie mogą być wymieniane wyłącznie przez producenta, jego serwis lub osobę wykwalifikowaną. Ⓢ Svetelný zdroj a predradník v tomto svetidle smie vymieňať len výrobca, jeho servis alebo kvalifikovaná osoba. Ⓢ Svetlobni vir in napajalnik v tej svetilki lahko zamenja le proizvajalec, njegov servis ali usposobljena oseba. Ⓢ Bu armatürdeki ışık kaynağı ve kontrol donanımı yalnızca üretici, yetkili servisi veya yetkin bir kişi tarafından değiştirilebilir. Ⓢ Izvor svetla i upravljački uređaj u ovoj svetiljci smiju zamjenjivati samo proizvođač, njegov servis ili kvalificirana osoba. Ⓢ Sursa de lumină și balastul conținute în acest corp de iluminat pot fi înlocuite doar de producător, de serviciul său autorizat sau de o persoană calificată. Ⓢ Светлинният източник и апаратът в това осветително тяло могат да се подменят само от производителя, неговия сервис или квалифицирано лице. Ⓢ Selles valgustis olevat valgusallikat ja toiteplokki võib vahetada ainult tootja, tema hoolduspartner või kvalifitseeritud isik. Ⓢ Šiame šviestu ve esantį šviesos šaltinį ir maitinimo įrenginį gali keisti tik gamintojas, jo servisas arba kvalifikuotas asmuo. Ⓢ Šā gaismekļa gaismas avotu ir vadības ierīci drīkst nomainīt tikai ražotājs, viņa serviss vai kvalificēta persona. Ⓢ Izvor svetlosti i upravljački uređaj u ovoj svetiljci smeju da zamene samo proizvođač, njegov servis ili kvalifikovano lice. Ⓢ Джерело світла та пускорегулювальний апарат у цьому світильнику можуть замінювати лише виробник, його сервіс або кваліфікована особа. Ⓢ Осы шамдағы жарық көзін және басқару құрылғысын тек өндіруші, оның сервистік өкілі немесе білікті адам ғана ауыстыра алады.

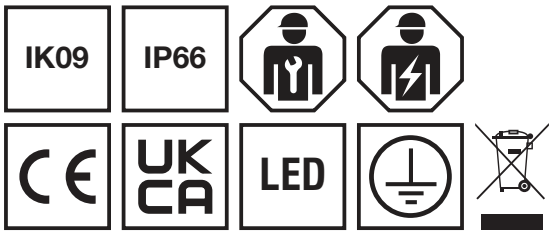

5MA80-267753\_ak  
22.04.2026 / KIN

Siteco GmbH  
Georg-Simon-Ohm-Straße 50  
83301 Traunreut, Germany  
mail: [technicalsupport@siteco.de](mailto:technicalsupport@siteco.de)  
Phone: +49 8669 / 33-844  
[www.siteco.com](http://www.siteco.com)