

Montageanleitung

Ⓒ mounting instruction Ⓕ Notice de montage Ⓒ Instrukcja montażu
Ⓔ Instrucciones de montaje ⓘ Istruzioni di montaggio

LENSES-AD...

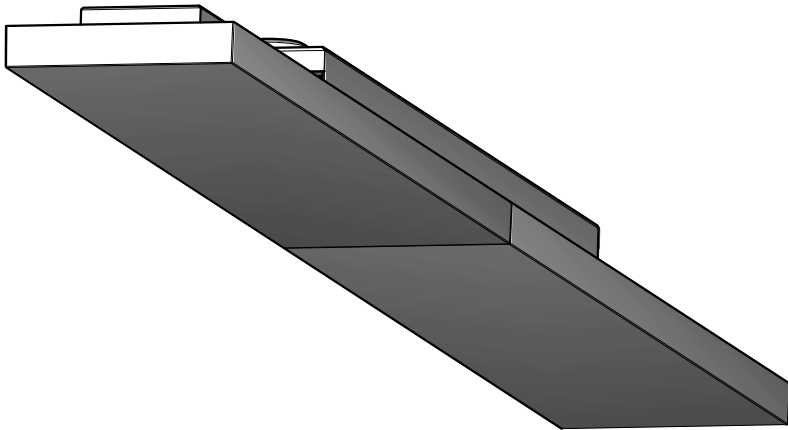

RIDI Leuchten GmbH
Hauptstrasse 31 - 33 · D-72417Jungingen
Tel. 07477/872-0 · Fax 07477/872-48
kontakt@ridi.de · www.ridi.de



- Ⓓ Für die Installation und für den Betrieb der Leuchten sind die nationalen Sicherheitsvorschriften zu beachten.
- ⒼⒹ Please note national safety instructions for installation and operation of this luminaire.
- Ⓕ Pour l'installation et le fonctionnement des luminaires il est impératif de respecter les normes nationales de sécurité en vigueur.
- Ⓗ W celu prawidłowej instalacji i poprawnego działania oprawy należy przestrzegać krajowych przepisów bezpieczeństwa.
- Ⓔ Para la instalación y la puesta en funcionamiento de las luminarias deben observarse las normas nacionales de seguridad.
- Ⓘ Per l'installazione e il funzionamento delle lampade si fa riferimento alle normative di sicurezza nazionali.

- Ⓓ Die Lichtquelle dieser Leuchte darf nur vom Hersteller oder einem von ihm beauftragten Servicetechniker oder einer vergleichbar qualifizierten Person ersetzt werden.
- ⒼⒹ Only the manufacturer, a trained service technician or another equally qualified person is permitted to replace the light source of this luminaire.
- Ⓕ La source lumineuse de ce luminaire ne peut être remplacée que par le fabricant, un technicien de service mandaté par celui-ci ou une personne présentant une qualification analogue.
- Ⓗ Wymiana źródła światła w tej oprawie oświetleniowej może dokonać wyłącznie producent bądź uprawniony pracownik serwisu albo osoba o podobnych kwalifikacjach.
- Ⓔ La fuente de luz de esta luminaria solamente podrá ser sustituida por el fabricante o una persona designada por este, ya sea un técnico de servicio u otra persona debidamente cualificada.
- Ⓘ La sorgente luminosa di tale lampada può essere sostituita solo dal produttore o da un tecnico di assistenza da questi designato oppure da personale dotato di qualifica equivalente.

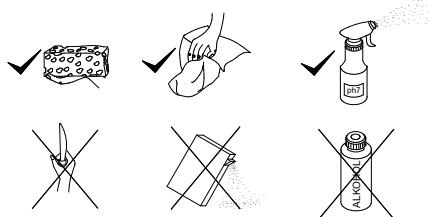
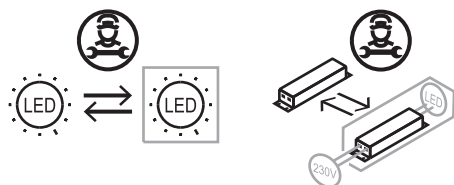

Druckfehler und Irrtum vorbehalten.
Formelle und technische Änderungen behalten wir uns vor.

Misprints and errors excepted.
We reserve the right of formal and technical modifications.

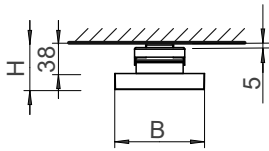
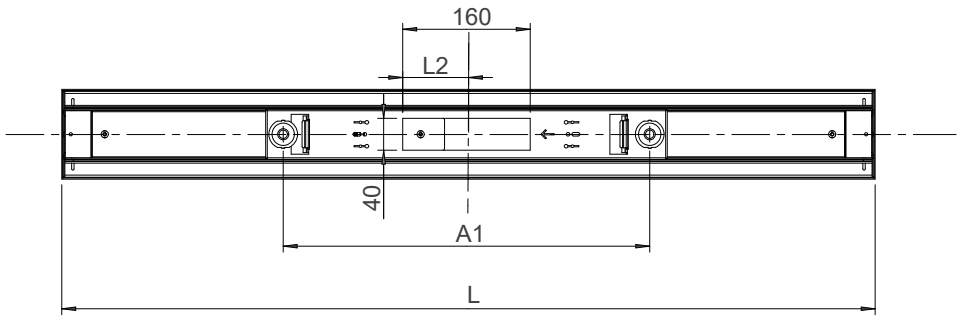

Typ	A1	L	B	L2	H	
LENSES-AD...1000	460	1021	113	83	58	170
LENSES-AD...1500	460	1526	113	53	58	220

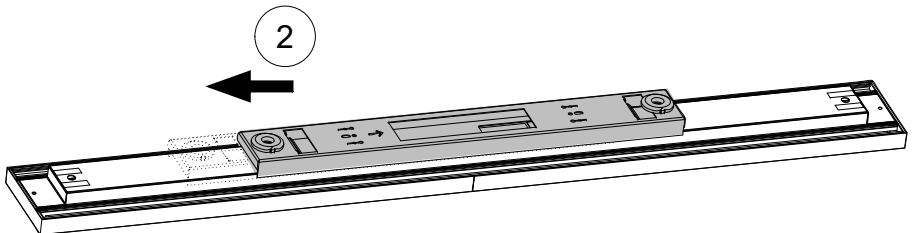
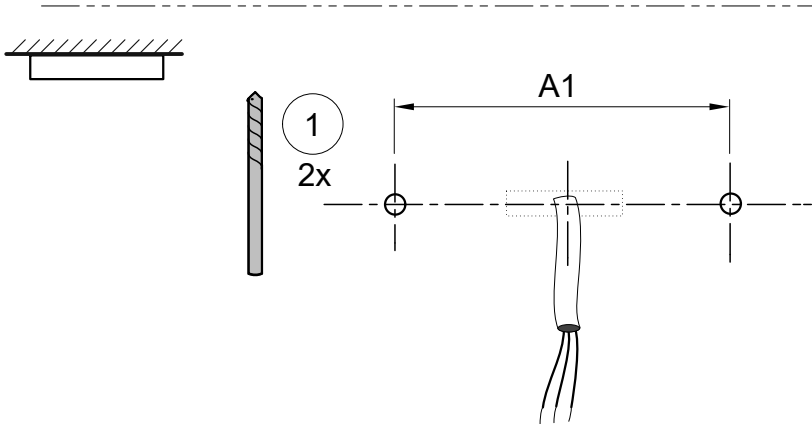

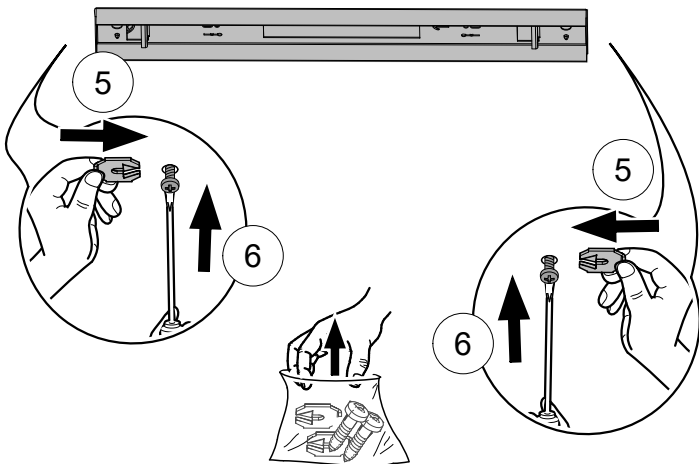
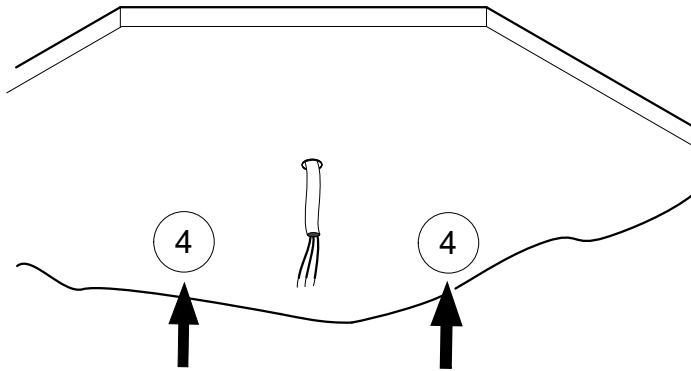
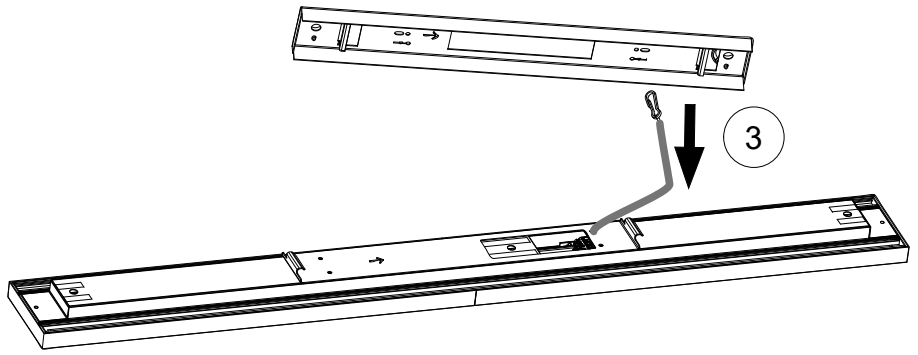

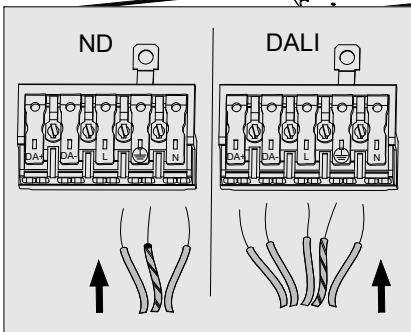
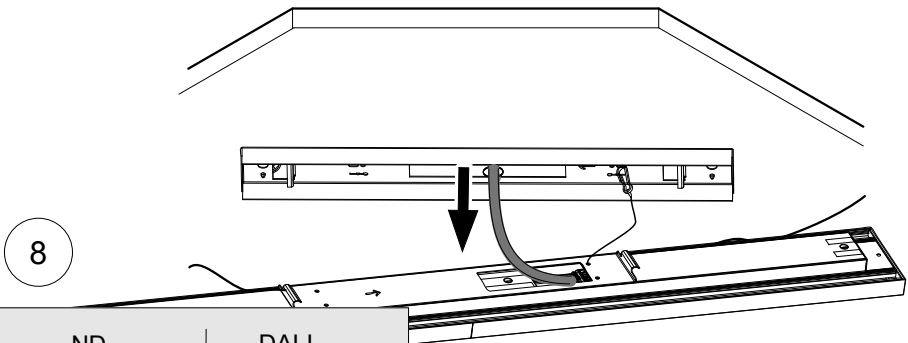
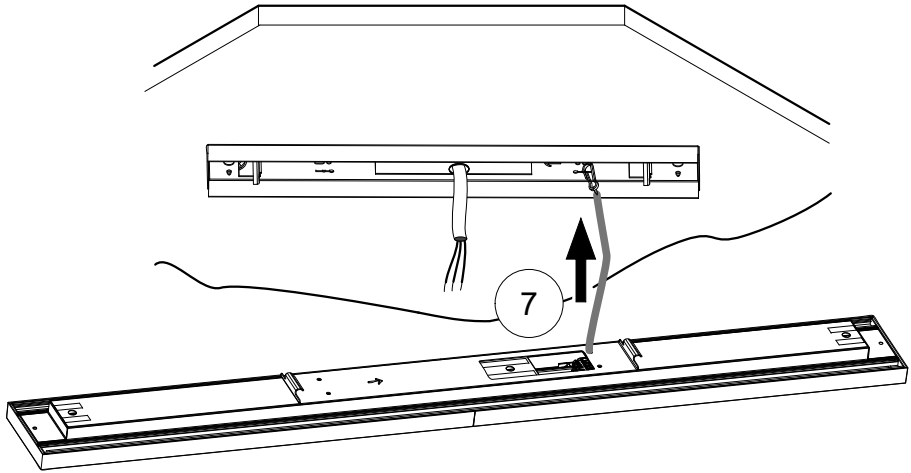

	Ø	A
	0,8-1,2	9
	max. Ø1,8mm	1,3-1,8

	mm ²	A
	sol. 0,5-1,0	9
	0,5-2,5mm ²	1,5-2,5

	mm ²	A
	0,8-1,2	9
	max. Ø1,8mm	1,3-1,8

RIDI
AC 220-240V/50-60Hz

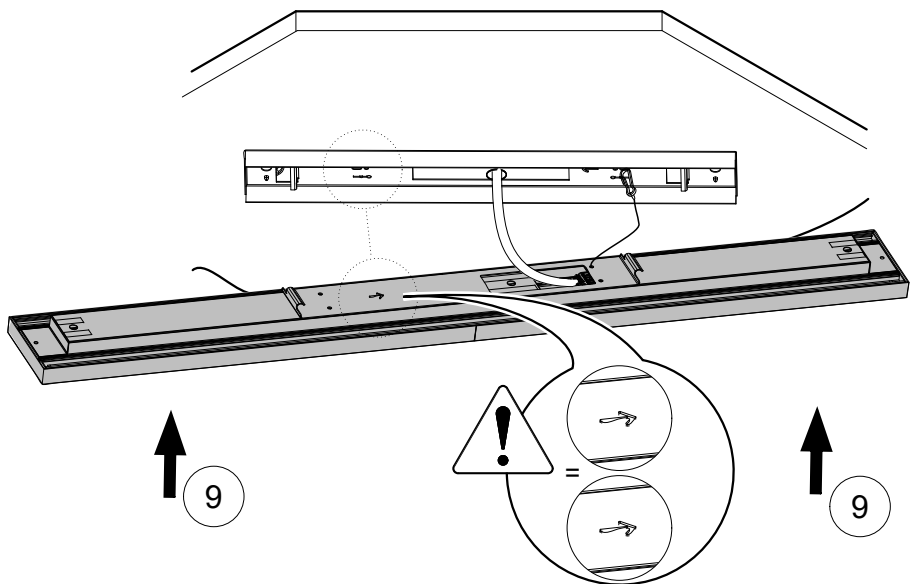

- Ⓓ Steckverbindung oder Leitung beim Verschließen der Leuchte nicht einklemmen.
- ⒼⒸ Do not pinch the plug connection or cable when closing the luminaire
- Ⓕ Ne pas coincer les connecteurs ou le câble lors de la fermeture du luminaire.
- Ⓗ Przy zamykaniu lampy nie należy ścisnąć złącza wtykowego ani przewodu
- Ⓔ No apriete la conexión del enchufe ni el cable al cerrar la luminaria
- Ⓘ Quando si chiude la lampada, non schiacciare il cavo o il connettore

