

Abisoliermaße *stripping instruction*

①

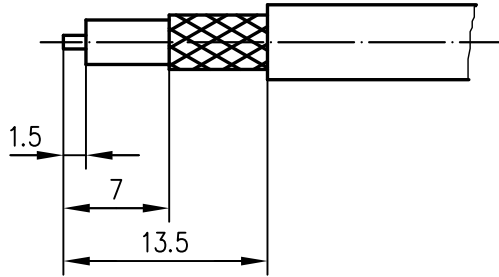

②

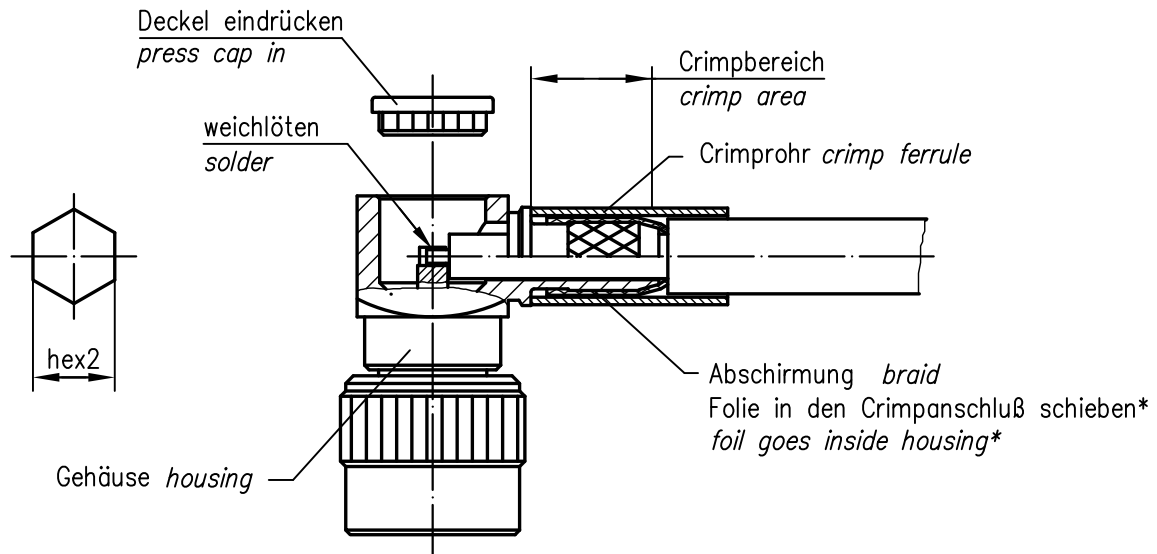
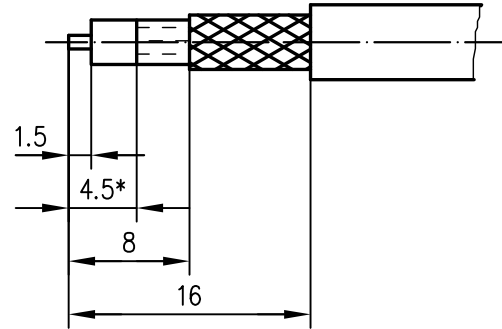

\* nur für Kabel mit Folie / *only for cables with foil*

XX	Crimpeinsatz <i>crimp insert</i>	6kt.1 x Länge <i>hex1 x length</i>	6kt.2 x Länge <i>hex2 x length</i>	Abisoliermaße <i>stripping instruction</i>	
03	N01003A0009		3.25x8	①	
05	N01003A0005		5.41x8	②	

f	23387	24.11.11	MA
e	12656	06.07.01	MA
d	10789	01.09.99	KL
c	10182	12.03.99	BJ
Index <i>index</i>	Änderung <i>modification</i>	Datum <i>date</i>	Name <i>name</i>

	Datum <i>date</i>	Name <i>name</i>
Gez. <i>drawn</i>	19.03.93	Beyer
Gepr. <i>app'd</i>	22.03.93	Poe

**Series Mini UHF crimp  
Serie Mini UHF crimp**

Untert. <i>Art</i>	TG-Nr. <b>T00100B1700</b>
-----------------------	------------------------------



Original <i>original</i>	A4	Blatt <i>sheet</i>	1/1
-----------------------------	----	-----------------------	-----

Maßstab <i>scale</i>	2:1
-------------------------	-----

Ersatz für/*replacement for*