

empfohlenes Anzugsmoment: 50 Ncm
recommended torque figure: 50 Ncm

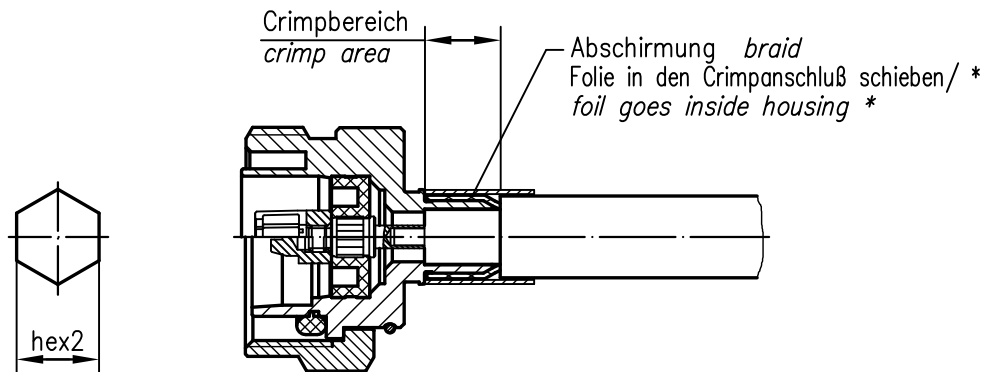

* nur für Kabel mit Folie / foil goes inside housing

XX	Crimpeinsatz crimp insert	6kt.1 x Länge hex1 x length	6kt.2 x Länge hex2 x length	
12	N01003D1274	2.54x2.3	10.9x10	①
26	N01003A0030	3.25x3.5	10.9x10	②

b	23387	13.12.11	MA
a	14550	23.05.03	HM
Index index	Änderung modification	Datum date	Name name

	Datum date	Name name
Gez. drawn	04.02.03	HM
Gepr. app'd	06.02.03	BJ

Series 7-16
Serie 7-16

Untert.- Art	TG-Nr.
R	T00100B3500



Original original	A4	Blatt sheet	1/1
----------------------	----	----------------	-----

Maßstab scale	1:1
------------------	-----

Ersatz für/replacement for