

# GoldenPower®

## PX27G

### TECHNICAL SPECIFICATION

### 技術規格書

### ECOTOTAL ALKALINE HIGH VOLTAGE BATTERY

### 源·自然系列 - 層疊式鹼性電池

<b>Approved</b>		
General Manager:		Date: 13/4/2017

Date            日期: 2017/04/10  
SPEC. No.      編號: GP001-PX27G  
REVISION      版次: 01

---

**GOLDEN POWER CORPORATION (HK) LTD.**

金力企業（香港）有限公司

Flat C, 20/F, Block 1, Tai Ping Industrial Centre, 57 Ting Kok Road, Tai Po, N.T. Hong Kong.

香港新界大埔汀角路 57 號太平工業中心第一座 20 樓 C 室

Tel 電話 : (852) 3125 2288      Fax 傳真: (852) 3125 2000 / (852) 3125 2001

E-mail 電郵 : battery@goldenpower.com      Web Page 網址 : <http://www.goldenpower.com>

---

**The Manufacturer reserves the right to modify product specification and data stated herein without prior notice**  
生產商對本產品技術規格如有更改，不另行通知。

## 1. Scope 概要

This specification is applicable to Golden Power's Ecototal Alkaline High Voltage Battery  
這技術規格是應用於金力: 源•自然系列-層疊式鹼性電池.

Model No. / 型號 :PX27G

### 1.1 Designations 型號

Golden Power:	PX27G	IEC:	---	Others:	4AG12
JIS:	---	ANSI:	---		

### 1.2 Reference Document 參考標準

- IEC 60086-1 (2015-07) - Primary Batteries - Part 1: General
- IEC 60086-2 (2015-10) - Primary Batteries - Part 2: Physical and Electrical Specification
- IEC 60086-3 (2016-05) - Primary Batteries - Part 3: Watch Batteries
- IEC 60086-5 (2016-07) - Primary Batteries - Part 5: Safety of batteries with aqueous electrolyte

## 2. Chemical System Zinc-Manganese Dioxide (Potassium Hydroxide Electrolyte)

化學構成 鋅 - 二氧化錳 (鹼性電解液)

## 3. Nominal Voltage 6V

標稱電壓

## 4. Weight approx. 7.9g

大約重量

## 5. Nominal Capacity 70mAh

標稱容量

Condition : continuous discharge at  $20 \pm 2^\circ\text{C}$  under  $20\text{k}\Omega$  load for 24 hrs/day to EPV 3.6V

條件 : 利用  $20\text{k}\Omega$  電阻, 在  $20 \pm 2^\circ\text{C}$  每日放電 24 小時, 終止電壓為 3.6V

## 6. Electrical Characteristics 電性能

Test Conditions tested within 30 days after delivery  
條件 收貨後 30 天內測試

load resistance temperature Measuring time  
負載電阻 100Ω ± 0.5% 測量溫度 20 ± 2°C 測量時間 0.3 sec

	Off-load voltage 空載電壓 (V)	On-load voltage 負載電壓 (V)	Test Specification 驗收規則
New Battery 新電	6.16	5.0	MIL-STD-105E, Class II, Double Sampling, AQL=0.4

## 7. Service Output 放電性能

Test Conditions tested within 30 days after delivery  
條件 收貨後 30 天內測試  
Temperature 20 ± 2°C  
測量溫度

Standard 標準	Discharge Condition 放電條件			Average Minimum Discharge Time 平均最少放電時間	
	Discharge load 放電負載	Daily discharge time 每天放電時間	End Point Voltage 終止電壓 (V)	New Battery 新電池	After 12 mth. at room temp. 在室溫下存放 12 個月
REF	20kΩ	24 hrs	3.6	200 hrs	180 hrs

Acceptance Criteria / 驗收標準 :

- (1) 9 pieces of battery will be tested for each discharging standard.  
每一種放電條件取 9 只電池進行放電。
- (2) The result of the average discharging time from each discharging standard shall be equal to or more than the average minimum time requirement; and no more than one battery has a service output less than 80% of the specified requirement.  
平均放電時間等於或大於平均最少放電時間的規定值，而放電時間少於規定值 80% 的電池數量不大於 1，則認為電池的放電時間符合要求。
- (3) One re-test is allowed to confirm the previous result.  
若以上結果不合格，可作一次重驗。

## 8. Safety Characteristics 安全性能

Item 項目	Condition 條件	Period 時間	Requirements 要求	Acceptance Standard 驗收標準
High Temp. storage 高溫儲存性能	Temp.: 57 - 60°C 溫度 57-60°C	10 days 10 天	There shall be no explosion of battery 電池沒有爆炸	/

## 9. Marking 標記

The following markings will be printed, stamped or impressed on the body of the battery:  
在電池外標明以下內容：



## 10. Caution for Use 注意事項

1. Since the battery is not manufactured for recharging, there are risks of electrolyte leakage or causing damage to the device if the battery is charged.  
請勿對電池進行充電，這樣可能會導致電池漏液，發生危險及對相關的充電設備造成破壞。
2. The battery shall be installed with its "+" and "-" polarity in correct position, otherwise may cause short-circuit.  
在安裝電池時，請把電池安裝在正確的方向，若安裝不正確或會造成短路。
3. Short-circuiting, heating, disposing of into fire and disassembling the battery are prohibited.  
請勿將電池短路、加熱、投入火中或試圖拆開。
4. Battery cannot be forced discharge, which lead to excess internal gas generation and, may result in bulging, leakage and de-crimping of cap.  
不可強行對電池進行放電，這樣可能會導致電池漏液或發生危險。
5. New and used batteries cannot be used at the same time, when replaced batteries recommend to replace all and with the same brand type.  
請盡量避免把新電池及已用過的電池同時使用。
6. Exhausted batteries should be removed from compartment to prevent over-discharge, which cause leakage & damage to the device.  
請把已耗盡的電池從用電的產品上移走，避免對電池進行過放，而引起電池漏液。
7. Direct soldering is not allowed, which will damage the battery.  
請勿焊接電池，這樣會對電池造成損害。
8. Battery should be kept out of the reach of children to prevent swallow, in case of accident should contact physician at once.  
電池應放在小童不可接觸的地方，以免小童誤吞電池。
9. The battery should not be dismantled and deformed.  
切勿把電池拆開。

**11. Shelf Life** 1 year after delivery, 90% of the capacity will be maintained after 1 year under proper storage conditions

**電池存放期** 於常溫及合適環境可儲存 1 年，1 年後電池可保留 90%容量。

Storage Conditions 存放條件

Temperature 20 ± 2°C

溫度

Relative humidity 55 ± 20% RH

相對濕度

**12. Discharge Curves 放電圖：**

Test temperature / 測試溫度	20 ± 2°C
Discharge Method(EPV) / 放電方法(終止電壓)：	20kΩ, 24 hrs/day (3.6V) Fig 1

**13. Battery Dimension and Structure**

電池尺寸 及 結構

Refer to Drawing DWG-S-002

參考圖紙 DWG-S-002

**14. Packaging Requirements 包裝要求**

14.1 For standard bulk package specification, please refer to ANNEX 1.

工業包裝標準，可參考附件 1

14.2 Packaging labels should be legible and permanent, label defects and special packaging identifications shall conform to mutually agreed specification and / or approved samples

包裝用標籤須符合易於辨認，清楚顯示及恆久性要求，標籤質量問題和其他特別包裝要求須另訂協議或按雙方樣板確認。

14.3 Other packaging for shipment and sales shall conform to mutual agreed packaging specification

客方特定包裝標準須另訂協議確認

**15. Compliance & Environmental Information 法規及環保信息**

This product complies with EU RoHS Directive 2002/95/EC, Battery Directive 2006/66/EC and 2013/56/EU and REACH Directive and REACH regulation EC No. 1907/2006.

此產品符合 歐盟 RoHS 指令 2002/95/EC, 電池指令 2006/66/EC、2013/56/EU 及 REACH 法規 EC. No. 1907/2006

Figure 1 / 圖 1: DISCHARGE CURVE 放電圖

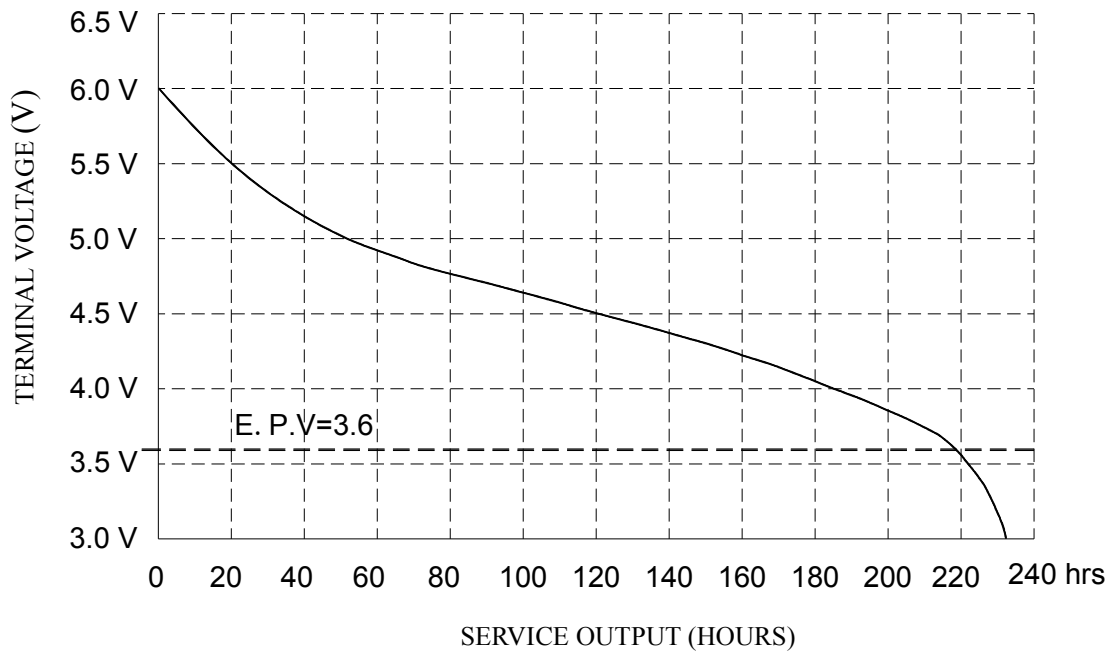

Test temperature / 測試溫度	20 ± 2°C
Discharge Method(EPV) / 放電方法(終止電壓):	20kΩ, 24 hrs/day (3.6V)

# PX27G DIMENSIONS & STRUCTURE

Dimensions (in mm):

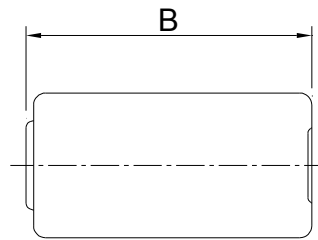
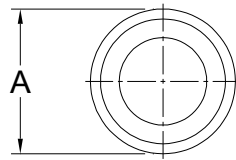

Dimensions	Specification
A	φ12.0 ~ 13.0
B	19.5 ~ 20.5

Structure:

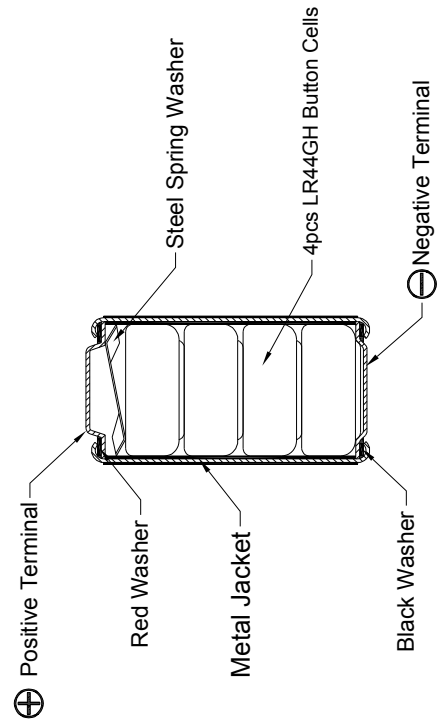

DWG-S-002

ANNEX 1 : Standard Bulk Package specification

