

# Rittal – The System.

Faster – better – everywhere.

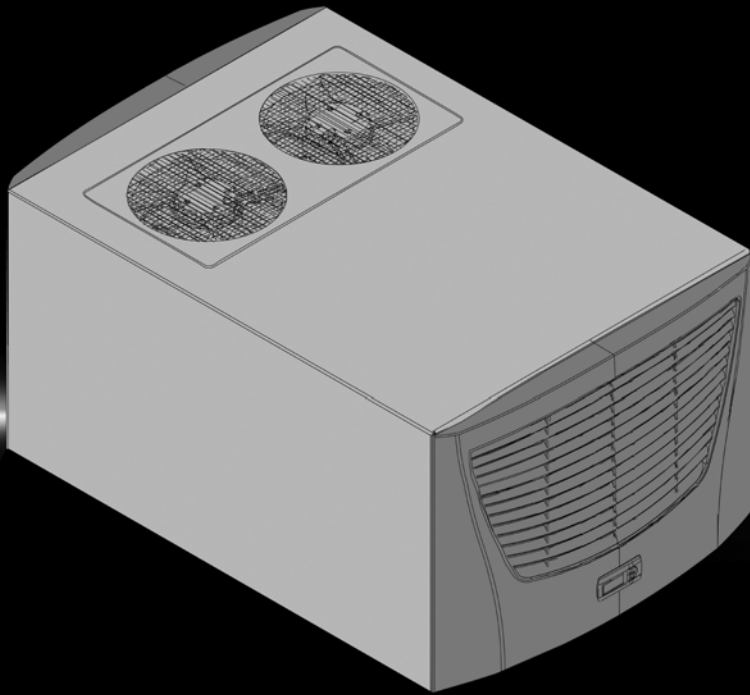

**IT-Dachaufbau-Kühlgerät**  
**IT roof-mounted cooling unit**

3301.800

**Montage-, Installations- und Bedienungsanleitung**  
**Assembly and operating instructions**

ENCLOSURES

POWER DISTRIBUTION

CLIMATE CONTROL

IT INFRASTRUCTURE

SOFTWARE & SERVICES

FRIEDHELM LOH GROUP



## Contents

<b>1</b>	<b>Notes on documentation</b> . . . . .	<b>3</b>	<b>5</b>	<b>Start-up</b> . . . . .	<b>13</b>
1.1	Associated documents . . . . .	3	<b>6</b>	<b>Operation</b> . . . . .	<b>14</b>
1.2	CE labelling . . . . .	3	6.1	Control using the controller . . . . .	14
1.3	Retention of documents . . . . .	3	6.1.1	Properties . . . . .	14
1.4	Symbols used . . . . .	3	6.1.2	Launching test mode . . . . .	14
<b>2</b>	<b>Safety notes</b> . . . . .	<b>3</b>	6.1.3	General programming information . . . . .	14
<b>3</b>	<b>Device description</b> . . . . .	<b>4</b>	6.1.4	Editable parameters . . . . .	15
3.1	Functional description . . . . .	4	6.1.5	Programming overview . . . . .	16
3.1.1	How it works . . . . .	4	6.1.6	Defining system messages for evaluation . . . . .	17
3.1.2	Control . . . . .	4	6.1.7	Setting the master-slave identifier . . . . .	18
3.1.3	Cooling output . . . . .	5	6.1.8	Evaluating system messages . . . . .	18
3.1.4	Bus mode . . . . .	5	6.1.9	Resetting the controller . . . . .	20
3.1.5	Safety devices . . . . .	5	<b>7</b>	<b>Inspection and maintenance</b> . . . . .	<b>20</b>
3.1.6	Condensation . . . . .	5	7.1	General . . . . .	20
3.1.7	Filter mats . . . . .	6	7.1.1	Compressed air cleaning . . . . .	20
3.1.8	Door limit switch . . . . .	6	<b>8</b>	<b>Storage and disposal</b> . . . . .	<b>22</b>
3.1.9	USB interface . . . . .	6	<b>9</b>	<b>Technical specifications</b> . . . . .	<b>23</b>
3.2	Proper use . . . . .	6	<b>10</b>	<b>List of spare parts</b> . . . . .	<b>24</b>
3.3	Scope of supply . . . . .	7	<b>11</b>	<b>Appendix:</b>	
3.4	Accessories required for the “front-to-back” air routing . . . . .	7		<b>Cut-out and hole sizes</b> . . . . .	<b>25</b>
<b>4</b>	<b>Assembly and connection</b> . . . . .	<b>7</b>	11.1	Dimensions for assembly . . . . .	25
4.1	Choosing the installation site . . . . .	7			
4.2	Notes on assembly . . . . .	7			
4.2.1	Order of assembly . . . . .	7			
4.2.2	General . . . . .	7			
4.2.3	Layout of the components in the enclosure . . . . .	8			
4.3	Fitting the cooling unit . . . . .	8			
4.3.1	Making the cut-outs . . . . .	8			
4.3.2	Top mounting of the cooling unit . . . . .	8			
4.4	Connecting the condensate discharge . . . . .	9			
4.5	Notes on electrical installation . . . . .	9			
4.5.1	Connection data . . . . .	9			
4.5.2	Overvoltage protection and supply line load . . . . .	9			
4.5.3	Door limit switch . . . . .	10			
4.5.4	Notes on the flicker standard . . . . .	10			
4.5.5	Potential equalisation . . . . .	10			
4.6	Making the electrical connection . . . . .	10			
4.6.1	Bus connection . . . . .	10			
4.6.2	Installing the power supply . . . . .	12			
4.7	Finalising assembly . . . . .	13			
4.7.1	Installing the filter media . . . . .	13			
4.7.2	Fitting the cooling unit . . . . .	13			
4.7.3	Setting the filter mat monitor . . . . .	13			

## 1 Notes on documentation

These assembly instructions are aimed at

- tradespersons who are familiar with assembly and installation of the cooling unit
- trained specialists who are familiar with operation of the cooling unit

### 1.1 Associated documents

Assembly and operating instructions exist as paper documents and/or on CD-ROM for the unit types described here and are enclosed with the equipment. We cannot accept any liability for damage associated with failure to observe these instructions. Where applicable, the instructions for any accessories used also apply.

### 1.2 CE labelling

The declaration of conformity is supplied with the unit as a separate document.

### 1.3 Retention of documents

These instructions and all associated documents constitute an integral part of the product. They must be given to the plant operator. The operator is responsible for storage of the documents so they are readily available when needed.

### 1.4 Symbols used

- 
- **The bullet point indicates an action to be performed.**
- 



**Danger!**  
Immediate danger to life and limb!

---



**Caution!**  
Potential threat to the product and the environment.

---



**Note:**  
Useful information and special features.

---

## 2 Safety notes

Please observe the following general safety notes when assembling and operating the unit:

- Assembly, installation and servicing may only be performed by properly trained specialists.
- Do not obstruct the air inlet and air outlet of the cooling unit inside and outside the enclosure (see also section “4.2.3 Layout of the components in the enclosure”, page 8).
- The heat loss of the components installed in the enclosure must not exceed the specific useful cooling power of the cooling unit.
- The cooling unit must always be transported in a horizontal position.
- Use only original spare parts and accessories.
- Do not make any changes to the cooling unit other than those described in these instructions or associated instructions.
- Risk of burns! On cooling units with automatic condensate evaporation, the surface of the thermal element will get very hot during operation, and will remain so for some time afterwards.
- The mains connector of the cooling unit must only be connected and disconnected with the system de-energised. Connect the pre-fuse specified on the rating plate.

# 3 Device description

## 3 Device description

Depending on the model chosen, your cooling unit may vary in appearance from the illustrations contained in these instructions. However, the functions are identical in principle.

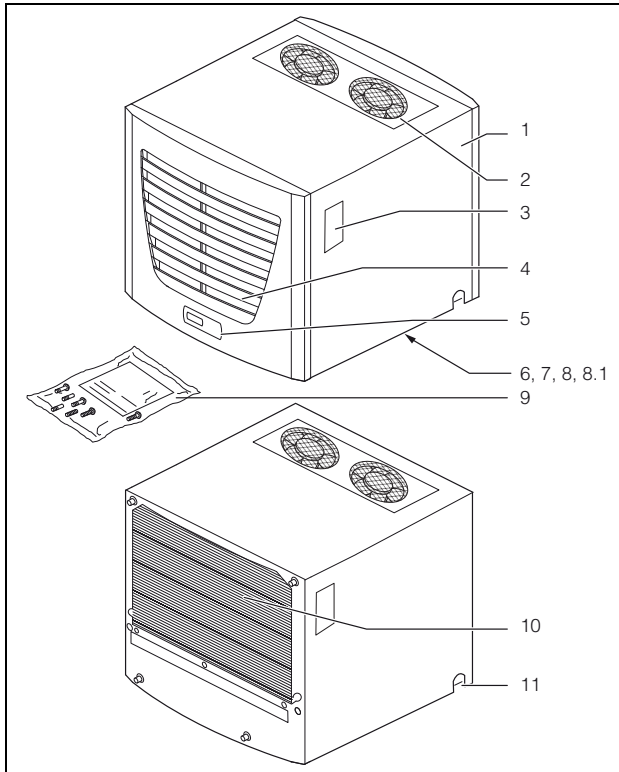

Fig. 1: Device description

### Key

- 1 Enclosure
- 2 Air outlet holes
- 3 Rating plate
- 4 Louvred grille for air inlet
- 5 Display
- 6 X2 master-slave connection (underside of the unit)
- 7 X1 terminal strip (underside of the unit)
- 8 X3 optional serial interface (underside of the unit)
- 8.1 X10 USB interface
- 9 Dispatch bag
- 10 Condenser
- 11 Condensate discharge

### 3.1 Functional description

The IT roof-mounted cooling unit has been designed for the direct cooling of server equipment in the enclosure. The hot air from the servers (rear area) is drawn in through the unit's central extractor opening, and forced in front of the 482.6 mm (19") level again after being cooled down. The side partitions and the air baffle plate in the 482.6 mm (19") level produce a cold air veil in front of the 482.6 mm (19") level, from which the 482.6 mm (19") equipment draws air for cooling.

### 3.1.1 How it works

The cooling unit (compression refrigeration system) comprises four main components (see fig. 2): the evaporator (1), the refrigerant compressor (2), the condenser (3), and the control or expansion valve (4), which are connected by suitable pipework. This circuit is filled with a readily boiling substance, the refrigerant. The refrigerant R134a ( $\text{CH}_2\text{FCF}_3$ ) is chlorine-free. Its Ozone Depletion Potential (ODP) is 0, making it very eco-friendly. A filter dryer (5) which is integrated into the hermetically sealed cooling circuit provides effective protection against moisture, acid, dirt particles, and foreign bodies within the cooling circuit.

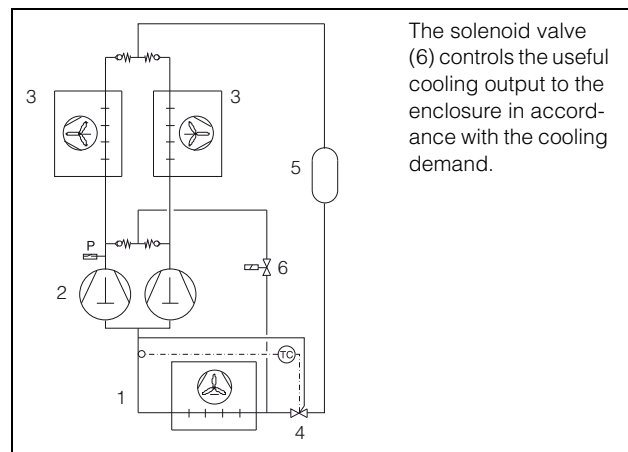

Fig. 2: Cooling circuit

In the evaporator coil (1), the liquid refrigerant is converted to a gaseous state. The energy needed for this purpose is taken from the enclosure air in the form of heat, which has the effect of cooling the enclosure air. In the compressor (2), the refrigerant is heavily compressed, so that it achieves a higher temperature inside the condenser (3) than the ambient air. This means that excess heat may be emitted to the ambient air via the surface of the condenser, as a result of which the temperature of the refrigerant drops and it is converted back into liquid. It is re-injected into the evaporator coil via a thermostatic expansion valve (4), which causes it to cool down further, and is then once again able to absorb the energy from the enclosure air in the evaporator coil. The whole cycle begins again.

### 3.1.2 Control

To ensure optimal cooling of the server, control is based on the supply air temperature. The setpoint temperature, which is adjustable via the controller, is kept as constant as possible by the precise control of the output from the cooling circuit. During this process, the supply air temperature is maintained close to the setpoint temperature by means of a hot gas bypass, hot refrigerant being removed from the discharge side of the compressor and fed directly back into the cooling circuit, via a valve, on the suction side of the compressor.

Both compressors work in continuous operation, without any switching cycles.

Continuous operation also prevents voltage fluctuations and EMC irradiation from high start-up currents, which, in the worst case, can cause disturbing interference in the power line. When the cooling unit is utilised optimally, a maximum deviation of  $\pm 2$  K is achieved; larger fluctuations are only possible with very low heat losses.

### 3.1.3 Cooling outputs

The maximum cooling output, which depends on the ambient air temperature and the heat dissipated by the servers installed in the enclosure, can be estimated using the diagram below.

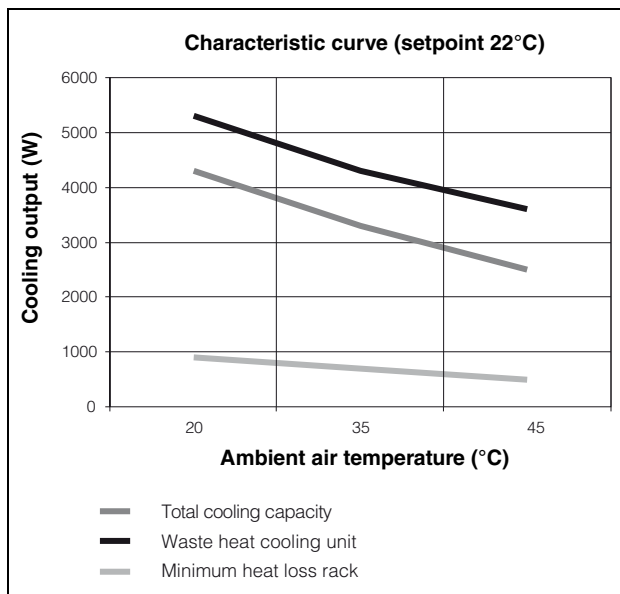

Fig. 3: Cooling output plotted against ambient air temperature for a setpoint temperature of 22°C



**Note:**

Always ensure adequate ventilation at the place of installation so as to avoid excessive local warming. If necessary, excessive warming of the server room can be prevented by installing an exhaust air duct.

**The heat losses in the rack should be at least 1000 W. Should the heat losses be less than 1000 W then it is not possible to control the supply air temperature to the specified accuracy of  $\pm 2$  K.**

Threaded inserts are provided in the upper section of the housing for attaching an exhaust air duct. Please note that the installed fans have been selected to operate against no external resistance and therefore an additional fan may be required to move the air through the duct due to the increased system pressure.

In case of doubt, please consult a local ventilation installation company.

### 3.1.4 Bus mode

The serial unit interface X2 allows you to create a bus connection with up to ten cooling units using the master-slave cable (shielded, four-wire cable, Model No. 3124.100).

This allows you to implement the following functions:

- Parallel unit control (the cooling units in the network can be switched on and off simultaneously)
- Parallel door status message (“door open”)
- Parallel collective fault message

Data is exchanged via the master-slave connection. During commissioning, assign an address to each unit that also includes the identifier “master” or “slave”.

### 3.1.5 Safety devices

- In the cooling cycle, the cooling unit has a tested pressure-operated switch to EN 12 263 which is set to maximum PS (permissible pressure); this operates via an automatic reset device whenever the pressure drops again.
- Temperature monitoring prevents the evaporator coil from icing over. If there is a risk of icing, the compressor switches itself off and automatically switches itself back on again at higher temperatures.
- The coolant compressor and the fans are equipped with thermal winding shields to protect against excess current and excess temperatures.
- In order to allow a reduction of pressure inside the compressor and hence a safe restart, once it has been switched off (e.g. upon reaching the set temperature via the door limit switch function or via de-energising), the device will switch back on with a delay of 180 seconds.
- The device has two integral floating contacts on the terminal block (system message relay with changeover contact, terminals 3 – 5), which may be used to alert the user in the event of a fault, e.g. via PLC.

### 3.1.6 Condensation

At high levels of humidity and low temperatures inside the enclosure, condensation may form on the evaporator coil.

The cooling units have an automatic electrical condensate evaporator. The thermal component used for this purpose is based on self-regulating PTC technology. Condensate arising on the evaporator coil is collected in a tank in the internal circuit of the cooling unit. When the water level rises, the water enters the PTC thermal component and is evaporated (through-flow heater principle). The water vapour streams out of the cooling unit with the airflow from the external fan.

## 3 Device description

EN

The PTC thermal component is permanently connected and has no switchpoint. It is protected against short-circuits with miniature fuses. If the fuse has tripped, any condensation is drained off via the safety overflow.

In the case of a malfunction or a failure in the thermal component, the condensation water is routed out of the unit via a drain pipe at the side or rear for safety reasons. For this purpose, a hose must be connected to the condensate nozzle (see "4.4 Connecting the condensate discharge", page 9). Condensate hoses are available as accessories (refer also to the accessories section in the Rittal Catalogue).

### 3.1.7 Filter mats

The entire cooling unit condenser is covered with a dirt-repelling, easy-to-clean RiNano coating. In many applications, therefore, the use of filter media is unnecessary, particularly with dry dusts. For dry, coarse dust and lint in the ambient air, we recommend installing an additional PU foam filter mat (3286.500) in the cooling unit. Depending on the incidence of dust, you will need to check the filter mat regularly and, if necessary, replace it. For air containing oil condensate, we recommend the use of metal filters (3286.510). These may be cleaned with suitable detergents and reused. When used in textile plants with heavy lint contamination, lint screens should be used (available as an optional extra).

Function of the filter mat monitor:

Dirt on the filter mat is automatically determined by measuring the temperature difference in the external circuit of the cooling unit. As the level of filter mat soiling rises, the temperature difference will increase. The setpoint value of the temperature difference in the external circuit adapts automatically to the relevant operating points in the performance diagrams. Hence there is no need to readjust the setpoint value for different operating points of the cooling unit.

### 3.1.8 Door limit switch

The cooling unit may be operated with a floating door limit switch connected. The door limit switch is not included with the supply (available as an accessory, Model No. 4127.010).

The door limit switch function causes the fans and the compressor in the cooling unit to be switched off after approximately 15 seconds when the enclosure door is opened (contacts 1 and 2 closed). This prevents the formation of condensation inside the enclosure while the enclosure door is open. In order to prevent damage to the unit, it is equipped with an ON delay: The evaporator fan cuts back in with a delay of approximately 15 seconds after the door has been closed, while the condenser fan and compressor switch on after approximately 3 minutes.

### 3.1.9 USB interface

The internal temperature can be monitored additionally through the USB interface X10 (see software data sheet USB-TEMP).

If the CD does not run automatically when inserted into the CD/DVD drive, switch to the CD-ROM directory of the drive concerned and start the application directly with a double-click on the file "CDfirst.exe". Then follow the installation instructions displayed on the screen.

The software installs online manuals explaining use of the temperature measuring facility.

The USB port is used for monitoring of the inside temperature and exerts no active influence on the control.

## 3.2 Proper use

Rittal IT roof-mounted cooling units were developed and designed in accordance with the state of the art and the recognised rules governing technical safety. Nevertheless, if used improperly, they may pose a threat to life and limb or cause damage to property. The unit is intended exclusively for the cooling of network and server enclosures with a "front-to-back" air routing. Any other use is deemed improper. The manufacturer will not be liable for any damages caused as a result of improper use, or for incorrect assembly, installation or use. All risk is borne solely by the user.

Proper usage also includes the observation of all valid documents and compliance with the inspection and servicing conditions.

### 3.3 Scope of supply

The unit is supplied in a packaging unit in a fully assembled state.

Please check the delivery for completeness:

Qty.	Description
1	IT roof-mounted cooling unit
1	Dispatch bag:
1	– Sealing material
1	– Plug-in terminal strip
1	– Assembly, installation and operating instructions
1	– Declaration of conformity
1	– CD-ROM for the visualisation of temperatures on a network computer, including instructions on use
1	Air baffle plate
1	Drilling template

Tab. 1: Scope of supply

### 3.4 Accessories required for the “front-to-back” air routing

- Front air baffle plates for 600 mm or 800 mm wide enclosures
- Side partition/air baffle plates (not included in scope of supply) side air baffle plates for TS IT
  - 600 x 2000 mm, **Model No. 5501.805**
  - 800 x 2000 mm, **Model No. 5501.815**
  - 600 x 2200 mm, **Model No. 5501.825**
  - 800 x 2200 mm, **Model No. 5501.835**
- Blanking panels (optional) **Model No. 715X.XXX**, to seal **unassigned U**.

## 4 Assembly and connection

### 4.1 Choosing the installation site

When choosing the installation site for the enclosure, please observe the following:

- The site for the enclosure, and hence the arrangement of the cooling unit, must be carefully selected so as to ensure good ventilation. Depending on the siting of the unit, if several units are installed directly adjacent to one another, the distance from the wall or ceiling must be at least 200 mm.
- The cooling unit must be installed and operated in a horizontal position (maximum deviation: 2°).
- The site must be free from excessive dirt and moisture.
- The ambient temperature must not exceed 45°C.
- It must be possible to fit a condensate discharge (see “4.4 Connecting the condensate discharge”, page 9).
- The mains connection data as stated on the rating plate of the unit must be guaranteed.

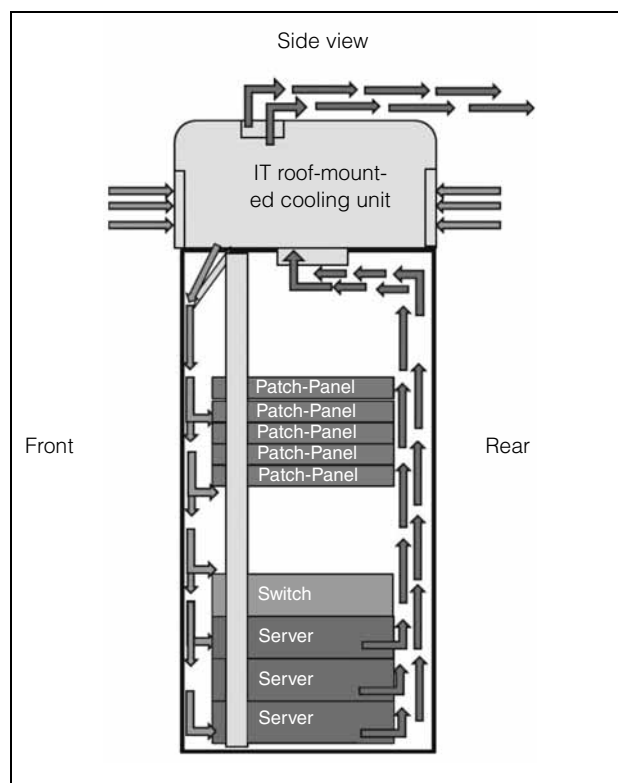

Fig. 4: Schematic of “front-to-back” air routing

### 4.2 Notes on assembly

#### 4.2.1 Order of assembly

Roof cut-out according to drawing (template).

- Mount the front 482.6 mm (19”) level at a depth of 150 mm.
- Fit the air baffle plates.
- Mount the cooling unit on the frame.

#### 4.2.2 General

- Check the packaging carefully for signs of damage. Traces of oil on damaged packaging are an indication of refrigerant loss and leakages. Packaging damage may be the cause of a subsequent functional failure.
- In case of excessive condensate formation, check the sealing of the IT rack. The enclosure must be sealed on all sides.
- In order to avoid excessive condensation inside the enclosure, we recommend installing a door limit switch (e.g. 4127.010) which deactivates the cooling unit when the enclosure door is opened (see “3.1.8 Door limit switch”, page 6).
- To achieve an optimum cooling performance, the 482.6 mm (19”) level in the front section of the rack should be set back as far as possible, but by at least 150 mm. Avoid hindrances or obstacles for the cold air blown down in front of the 482.6 mm (19”) level from the cooling unit.

# 4 Assembly and connection

## 4.2.3 Layout of the components in the enclosure



**Caution!**  
**Risk of condensation!**  
 When arranging the components inside the IT enclosure, please ensure that the cold airflow from the cooling unit is not directed at active components.



**Note:**  
 Exercise particular caution with the airflow from the blowers of built-in electronic components. Components for targeted air routing are available as accessories – please refer to Rittal Catalogue.  
 Ensure adequate separation of the cold and warm air sides. The side partitions and the air baffle plate in the roof area of the 482.6 mm (19") level must be in place. Any unused rack modules **must** be closed with blanking panels (air short-circuit).

## 4.3 Fitting the cooling unit

The IT roof-mounted cooling unit is mounted on top of the IT rack roof: To this end, the roof plate must be cut out as per the drilling template included with the supply.

### 4.3.1 Making the cut-outs

■ Affix the supplied drilling template to the roof of the IT enclosure using adhesive tape.  
 There are dimensioning lines on the drilling template to suit the installation type for your cooling unit.



**Risk of injury!**  
**Carefully deburr all cut-outs to prevent injuries caused by sharp edges.**

- Make the cut-outs including the line width as per the drilling template.
- Deburr the cut-outs.

### 4.3.2 Top mounting of the cooling unit

- Affix the supplied sealing frame onto the cut out roof plate.

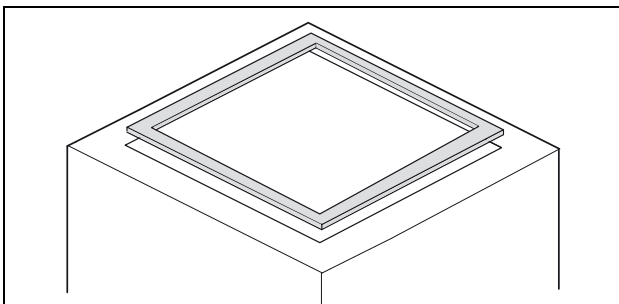

Fig. 5: Sealing frame on roof plate

- Screw the supplied twin-threaded bolts into the core holes in the plastic base on the underside of the cooling unit with a maximum of 5 Nm.
- Secure the unit using the supplied washers and nuts.



**Note:**  
 In order to achieve a permanent seal between the cooling unit and the enclosure, the mounting surface should be reinforced or supported if necessary. This is particularly applicable with large roof areas.

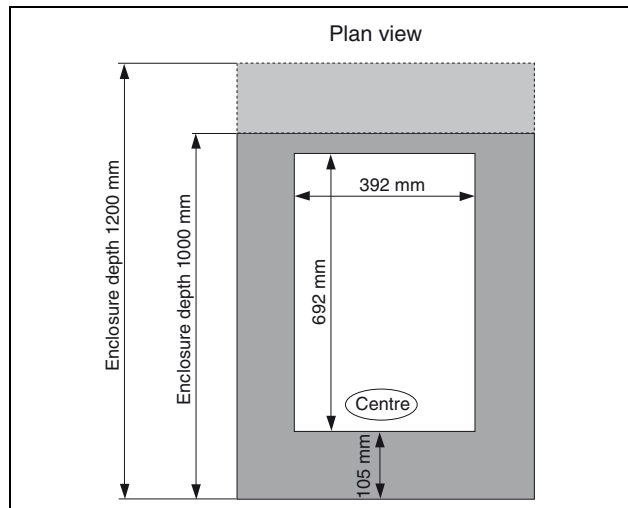

Fig. 6: Dimensions of the roof cut-out

### Accessories for roof plate reinforcement with TS:

- Punched rail
- U nut
- Fastening bracket
- Threaded block
- (refer also to Accessories in the Rittal Catalogue)

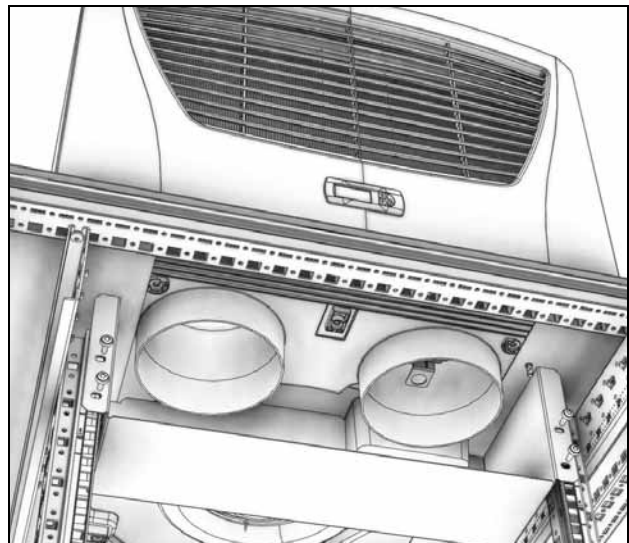

Fig. 7: Installation of air baffle plate

- Mount the supplied air baffle plate in the top U of the 482.6 mm (19") level.  
 For optimum operation and to avoid an air short circuit, the air baffle plate must be mounted in the top U.



## 4.4 Connecting the condensate discharge

A condensate discharge hose ( $\varnothing 1/2''$ ) may be fitted to the cooling unit.

The condensate discharge

- must be laid with a suitable and constant gradient (no siphoning)
- must be laid without kinks
- must not have a reduced cross-section if extended

The condensate hose is available as an accessory (3301.612).

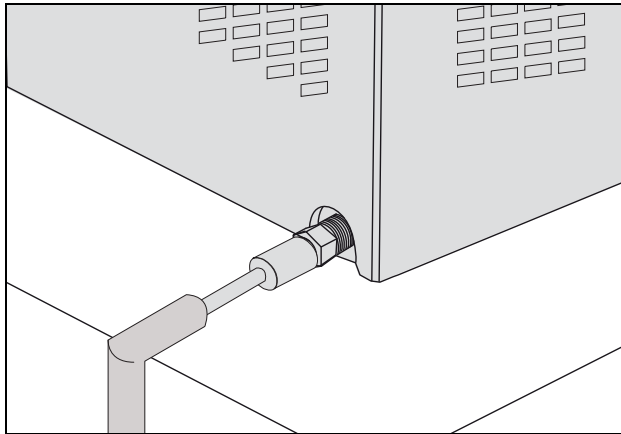

Fig. 8: Connecting the condensate discharge

- Connect the hose to the condensate nozzle and secure using a hose clip.
- Lay the condensate hose, e.g. into a drain.

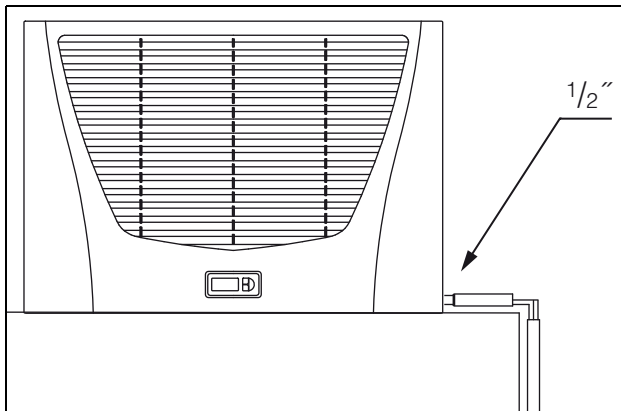

Fig. 9: Lay the condensate discharge

## 4.5 Notes on electrical installation

When performing the electrical installation, it is important to observe all valid national and regional regulations as well as the provisions of the responsible power supply company. Electrical installation must only be carried out by a qualified electrician who is responsible for compliance with the applicable standards and regulations.

### 4.5.1 Connection data

- The connected voltage and frequency must correspond to the values stated on the rating plate.
- The cooling unit must be connected to the mains via an all-pin isolating device, which ensures at least 3 mm contact opening when switched off.
- No additional temperature control may be connected upstream of the unit at the supply end.
- Install the pre-fuse specified on the rating plate to protect the cable and equipment from short-circuits.
- The mains connection must ensure low-noise potential equalisation.

### 4.5.2 Overvoltage protection and supply line load

- The unit does not have its own overvoltage protection. Measures must be taken by the operator at the supply end to ensure effective lightning and overvoltage protection. The mains voltage must not exceed a tolerance of  $\pm 10\%$ .
- In accordance with IEC 61 000-3-11, the unit is intended solely for use at sites with a continuous current-carrying capacity (incoming mains power supply) of more than 100 A per phase and with a supply voltage of 400/230 V. If necessary, the power supply company must be consulted to ensure that the continuous current-carrying capacity at the point of connection to the public grid is sufficient for connection of such a unit.
- The fans and compressors in single- and three-phase units are intrinsically safe (thermal winding protection). The same also applies to all transformer versions and to special-voltage units which are likewise equipped with a transformer.
- Install the slow pre-fuse specified on the rating plate (miniature circuit-breaker with “K” characteristic, motor circuit-breaker or transformer circuit-breaker) to protect the cable and equipment from short-circuits. Select a suitable motor circuit-breaker/transformer circuit-breaker in accordance with the information specified on the rating plate: Set it to the minimum specified value. This will achieve the best short-circuit protection for cables and equipment.

Example:

Specified setting range MS/TS 6.3 – 10 A; set to 6.3 A.

## 4 Assembly and connection

EN

### 4.5.3 Door limit switch

- Each door limit switch must only be assigned to one cooling unit.
- Several door limit switches may be connected in parallel to one cooling unit.
- The minimum cross-section of the connection cable is 0.3 mm<sup>2</sup> for a cable length of 2 m. We recommend the use of a shielded cable.
- The line resistance to the door limit switch must not exceed a maximum of 50 Ω.
- The door limit switch only supports a floating connection; no external voltages.
- The contact of the door limit switch must be closed when the door is open.

The safety extra-low voltage for the door limit switch is provided by the internal power pack: Current approx. 30 mA DC.

- Connect the door limit switch to terminals 1 and 2 of the connector.

### 4.5.4 Notes on the flicker standard

The flicker limits specified in standard EN 61 000-3 -3 or -3-11 are adhered to, provided the supply impedance is less than approx. 1.5 Ω.

Where necessary, the unit operator should measure the connected impedance or consult the responsible power supply company. If there is no way of influencing the supply impedance and sensitive installed components (e.g. BUS) are subjected to interference, a line reactor or starting-current limiting device should be connected upstream of the cooling unit to restrict the startup current of the cooling unit.

### 4.5.5 Potential equalisation

If, for EMC reasons, the unit is to be integrated into the existing potential equalisation system at the customer, a conductor with a larger nominal cross-section can be connected to the potential equalisation connection point (attachment points) on the roof-mounted cooling units.

According to the standard, the PE conductor in the mains connection cable is not classified as an equipotential bonding conductor.

## 4.6 Making the electrical connection

### 4.6.1 Bus connection

When using several cooling units, the serial device interface X2 can be used to connect up to ten cooling units with the bus cable (Model No. 3124.100).



#### Note:

The electrical signals at the X2 interface are of an extra-low voltage (not extra-low safety voltages to EN 60 335-1).

When interconnecting, please note the following:

- De-energise the cooling units to be connected.
- Ensure proper electrical insulation.
- Make sure the cables are not laid in parallel to power lines.
- Make sure that the lines are short.

# 4 Assembly and connection

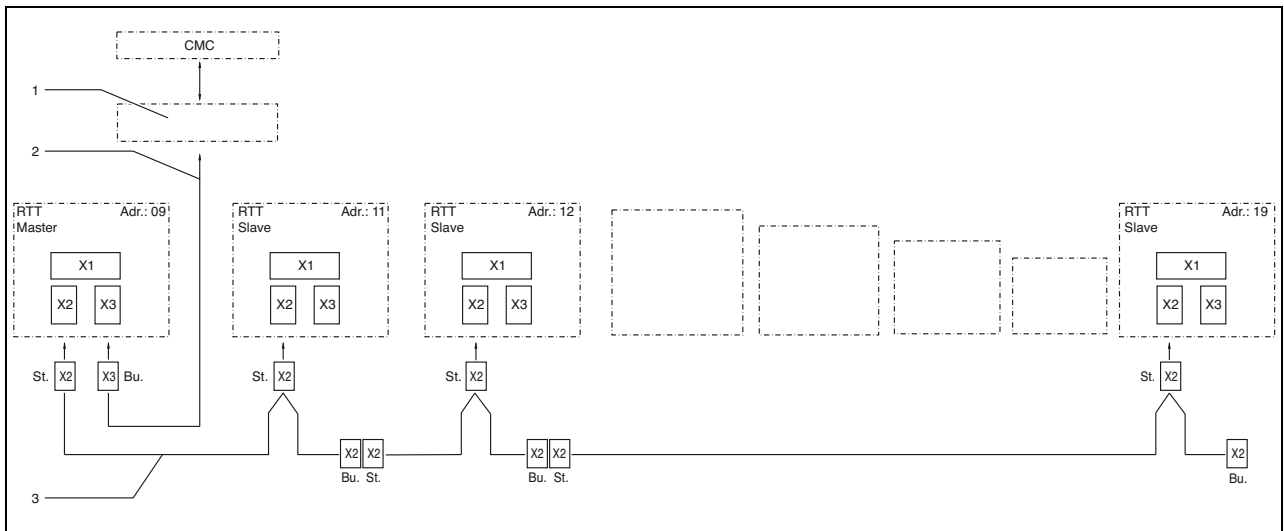

Fig. 10: Connection example: Master-slave operation

**Key**

- |     |   |      |                                       |
|-----|---|------|---------------------------------------|
| 1   | Serial interface                            | X2   | Master-slave connection Sub-D, 9-pole |
| 2   | Serial interface cable                      | X3   | Serial interface Sub-D, 9-pole        |
| 3   | Master-slave bus cable (Model No. 3124.100) | St.  | Sub-D connector, 9-pole               |
| RTT | Rittal TopTherm cooling units               | Bu.  | Sub-D jack, 9-pole                    |
| X1  | Supply connection/door limit switch/alarms  | Adr. | Address                               |

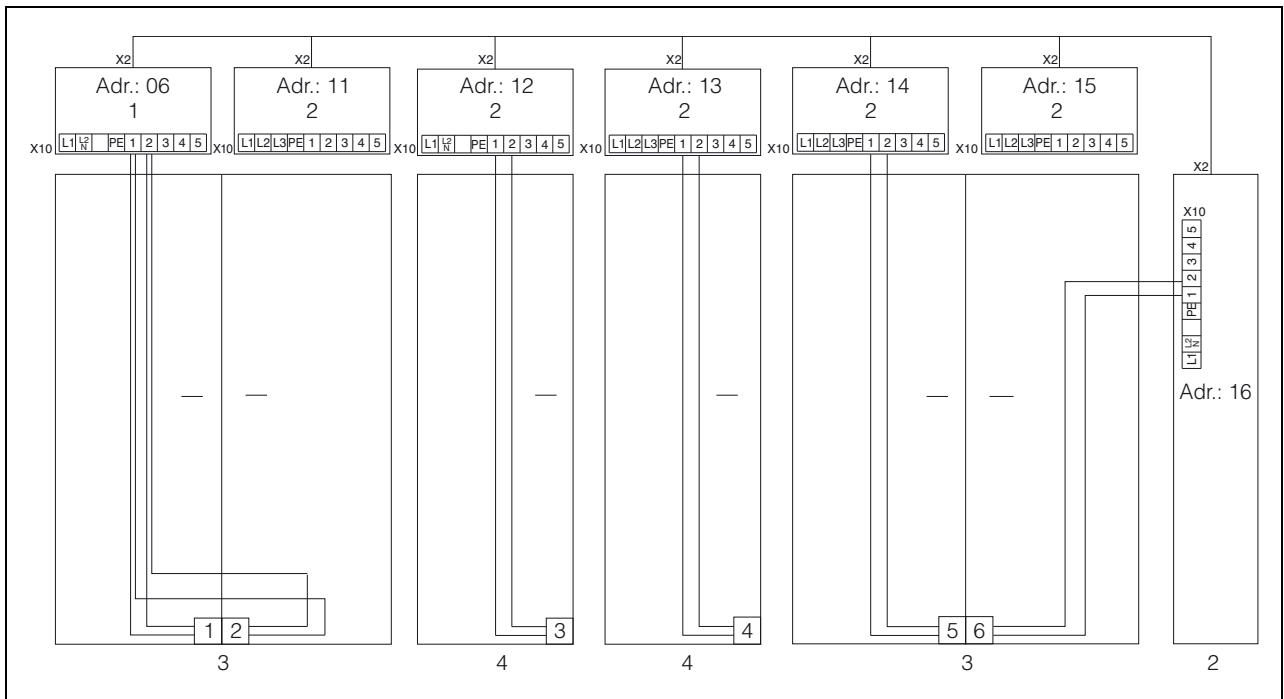

Fig. 11: Connection example: Door limit switch and master-slave operation

**Key**

- |   |   |
|---|---|
| 1 | Master cooling unit                           |
| 2 | Slave cooling units                           |
| 3 | 2-door enclosure with two door limit switches |
| 4 | Enclosure with door limit switch              |

# 4 Assembly and connection

## 4.6.2 Installing the power supply

■ Complete the electrical installation as per the wiring plan inside the cooling unit underneath the cable shaft cover (see fig. 26 on page 21, marked with an arrow).

■ If you would like the system messages from the cooling unit to be evaluated via the system message relay, you should also connect a suitable low-voltage cable to connection clamps 3 – 5.

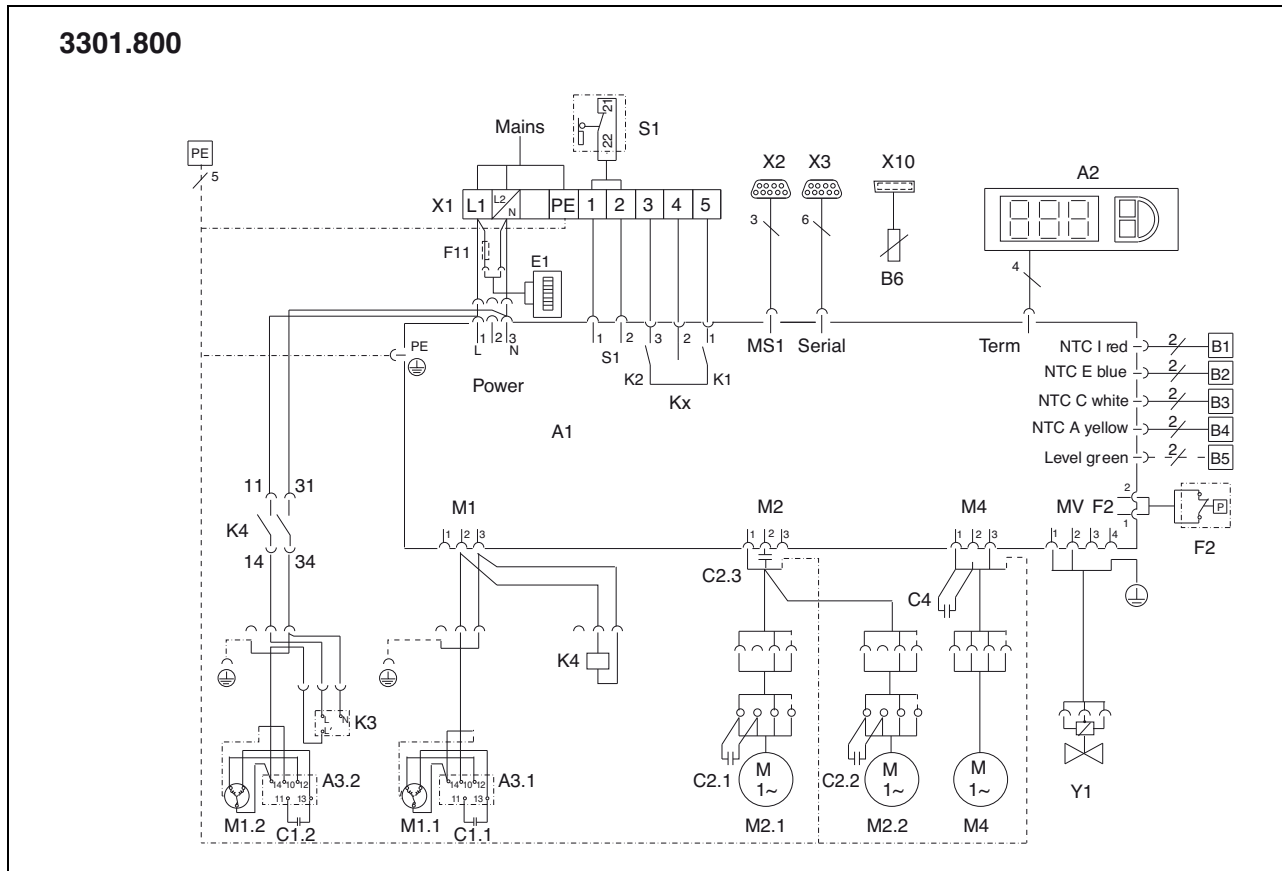

Fig. 12: Electrical wiring plan no. 1

### Key

A1	Power PCB
A2	Display terminal
A3.1	Starter relay 1
A3.2	Starter relay 2
B1	Temperature sensor, internal temperature
B2	Icing hazard temperature sensor
B3	Condenser temperature sensor
B4	Ambient temperature sensor
B5	Condensate warning sensor
B6	Sensor (optional)
C1.1/C1.2	Start-up capacitor
C2.3	Series capacitor
C2.X – C4	Running capacitors
E1	Condensate evaporator
F2	'PSA' pressure-operated switch
F11	Miniature fuse
K1	Relay collective fault 1
K2	Relay collective fault 2
K3	Time relay
K4	Contacteur compressor 2
Kx	Time relay
L1	LED operational green
L2	LED alarm red
M1.1	Compressor 1
M1.2	Compressor 2

M2.1	Condenser fan 1
M2.2	Condenser fan 2
M4	Evaporator fan
S1	Door limit switch (without, 1 – 2 open)
X1	Terminal strip
X2	Master-slave connection
X3	Optional interface
X10	USB port sensor
Y1	Hot gas bypass valve



### Note:

For technical data, refer to the rating plate.

AC cos f = 1	DC L/R = 20 ms
I max. = 2 A U max. = 250 V	I min. = 100 mA U max. = 200 V U min. = 18 V I max. = 2 A

Tab. 2: Contact data

## 4.7 Finalising assembly

### 4.7.1 Installing the filter media

The entire cooling unit condenser is covered with a dirt-repelling, easy-to-clean RiNano coating. In many applications, therefore, the use of filter media is unnecessary, particularly with dry dusts.

For dry, coarse dust and lint in the ambient air, we recommend installing an additional PU foam filter mat (3286.500) in the cooling unit. For air containing oil condensation, we recommend the use of metal filters (3286.510). When used in textile plants with heavy lint contamination, lint screens should be used (available as an optional extra).

- Pull the louvred air inlet grille off the enclosure.
- Insert the filter mat into the louvred grille as shown in fig. 13 and push it back onto the housing.

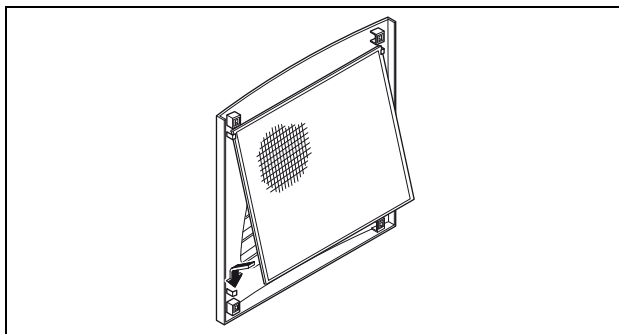

Fig. 13: Install the filter mat

### 4.7.2 Fitting the cooling unit

- Connect the connector to the rear of the display.
- Place the louvred grille onto the unit at the front, and press it down until you hear it snap into place.

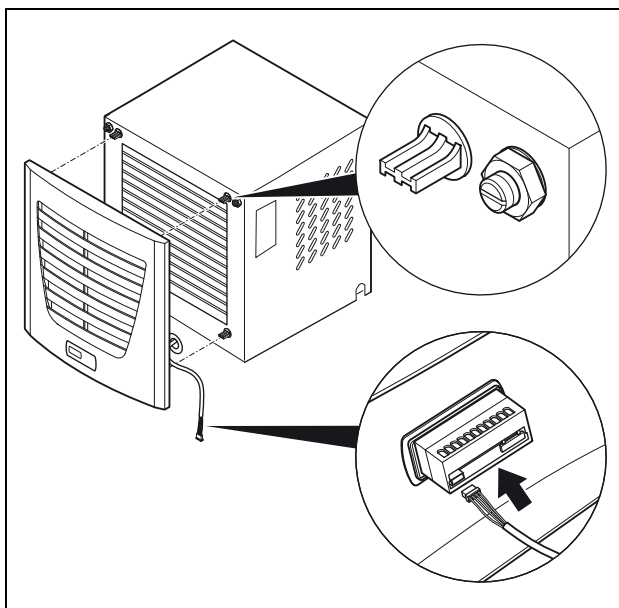

Fig. 14: Connect the display and attach the louvred grille

### 4.7.3 Setting the filter mat monitor

Function of the filter mat monitor:

Dirt on the filter mat is automatically detected by measuring the temperature difference in the external circuit of the cooling unit (see “6.1.5 Programming overview”, page 16). As the level of filter mat soiling rises, the temperature difference will increase. The setpoint value of the temperature difference in the external circuit adapts automatically to the relevant operating points in the performance diagrams. Hence there is no need to readjust the setpoint value for different unit operating points.

## 5 Start-up



### Caution! Risk of damage!

**The oil must be collected in the compressor in order to ensure effective lubrication and cooling.**

**Do not operate the cooling unit for at least 30 minutes after assembling the equipment.**

- Once all the assembly and installation work is complete, switch on the power supply to the cooling unit.

The cooling unit starts running:

The software version of the controller first appears for approx. 2 sec., then the enclosure internal temperature appears in the 7-segment display.

You can now make your individual settings on the unit, e.g. set the temperature or assign the network identifier, etc. (refer to chapter “6 Operation”, page 14).

# 6 Operation

## 6 Operation

You can operate the cooling unit using the controller on the front of the device (fig. 1, no. 5, page 4).

### 6.1 Control using the controller

For unit types xxxx.800.

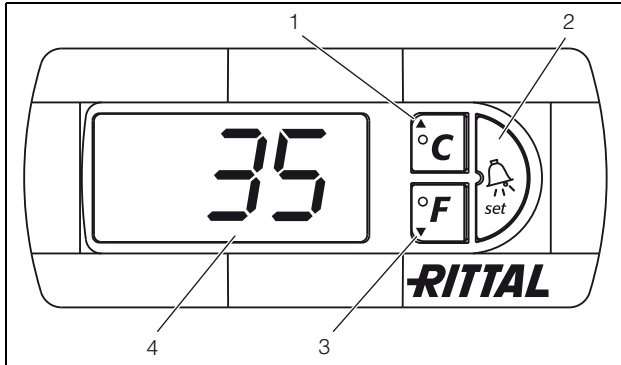

Fig. 15: Controller

#### Key

- 1 Programming button, also display of the set temperature unit (degrees Celsius)
- 2 Set button
- 3 Programming button, also display of the set temperature unit (degrees Fahrenheit)
- 4 7-segment display

#### 6.1.1 Properties

- Voltage: 230 V
- Integral start-up delay and door limit switch function
- Protective function to prevent icing
- Monitoring of all motors (compressor, condenser fan, evaporator fan)
- Master-slave function with a maximum of ten units. One device functions as a master unit. Once the set temperature is reached by one of the connected slave devices or in the event of the door limit switch function, the affected slave unit will report to the master unit, which will switch all the other cooling units on or off as required.
- Switching hysteresis: Adjustable within the range 2 – 10 K, preset to 2 K.
- Visualisation of the current enclosure internal temperature and all error messages in the 7-segment display.

The cooling unit operates automatically i.e. 15 seconds after switching on the power supply, the evaporator fan (see fig. 2, page 4) will start running. The compressor and condenser fan are regulated by the controller.

The controller has a 7-segment display (fig. 15, no. 4, page 14 ). After switching on the power supply, the current software version initially appears on this display for approx. 2 seconds.

In regular operation, the display shows both the temperature (in degrees Celsius or Fahrenheit – users may switch between the two) and any error messages.

The current enclosure internal temperature is usually displayed permanently. In the event of an error message, this will alternate with the temperature display. The unit is programmed using buttons 1 – 3 (fig. 15). The relevant parameters also appear in the display.

#### 6.1.2 Launching test mode

The controller is equipped with a test function whereby the cooling unit commences cooling operation independently of the set temperature or door limit switch function.

- Simultaneously press buttons 1 and 2 (fig. 15) for at least 5 seconds.

The cooling unit will commence operation.

After approximately 5 minutes or upon reaching 21°C, test mode will end. The unit switches off and changes to normal operation.

#### 6.1.3 General programming information

Using buttons 1, 2 and 3 (fig. 15) you can change 24 parameters within the preset ranges (min. value – max. value).

Tables 3 and 4 show the parameters which can be altered. Fig. 16 on page 16 shows which buttons must be pressed.



#### Note on temperature settings:

The temperature is preset at the factory to +22°C.

In order to save energy, and due to the risk of increased condensation, do not set the temperature lower than that actually necessary.

In principle, the programming is identical for all editable parameters.

To enter programming mode:

- Press button 2 (“Set”) for approx. 5 seconds.

The controller is now in programming mode. While in programming mode, if you do not press any buttons for approx. 30 sec., the display will first flash, then the controller will switch back to normal display mode. “Esc” in the display indicates that any changes made have not been saved.

- Press the programming buttons ▲ (°C) or ▼ (°F) to switch between the editable parameters (see tables 4 and 5).

- Press button 2 (“Set”) to select the displayed parameter for editing.

The current value of this parameter is displayed.

- Press one of the programming buttons ▲ (°C) or ▼ (°F).

“Cod” will appear in the display. In order to be able to change a value, you must enter the authorisation code “22”.

- Keep the programming button ▲ (°C) held down until “22” appears.

- Press button 2 (“Set”) to confirm the code.

You can now alter the parameter within the preset limits.

- Press one of the programming buttons ▲ (°C) or ▼ (°F) until the required value appears.

- Press button 2 (“Set”) to confirm the change.

You can now alter other parameters in the same way. There is no need to re-enter the authorisation code “22”.

- To exit programming mode, press button 2 (“Set”) again for approximately 5 seconds.

“Acc” will appear in the display to indicate that the changes have been saved. The display will then switch back to regular operation (internal enclosure temperature).

You can also program the controller using a diagnosis software package (Model No. 3159.100), which is supplied with a connection cable to the PC. The cable connector on the rear of the controller display serves as an interface.

#### 6.1.4 Editable parameters

See also fig. 16 on page 16.

Progr. level	Display screen	Parameter	Min. value	Max. value	Factory setting	Description
1	St	Internal enclosure temperature set-point $T_i$	20	22	22°C	The setting of the enclosure internal temperature is preset at the factory to 22°C and may be altered within a range of 20 – 22°C.
2	Fi	Filter mat monitoring	10	60	99 (= off)	To enable filter mat monitoring, the display should be set to a minimum of 10 K above the temperature difference shown in programming mode “Fi”; filter mat monitoring is disabled at the factory (99 = off).
3	Ad	Master-slave identifier	0	19	0	See “6.1.7 Setting the master-slave identifier”, page 18.
4	CF	Temperature conversion °C/°F	0	1	0	The temperature display can be switched between °C (0) and °F (1). The corresponding LED displays the current unit of temperature.
5	H1	Setting for switching difference (hysteresis)	1	10	1	The cooling unit is preset in the factory to a switching hysteresis of 1 K. This parameter should only be changed in consultation with us. Please contact us for advice.
6	H2	Differential for error message A2	3	15	5	If the internal enclosure temperature exceeds the set value by more than 5 K, then error message A2 (enclosure internal temperature too high) appears on the display terminal. If necessary, the differential may be altered here within the range of 3 – 15 K.

Tab. 3: Editable parameters

# 6 Operation

## 6.1.5 Programming overview

EN

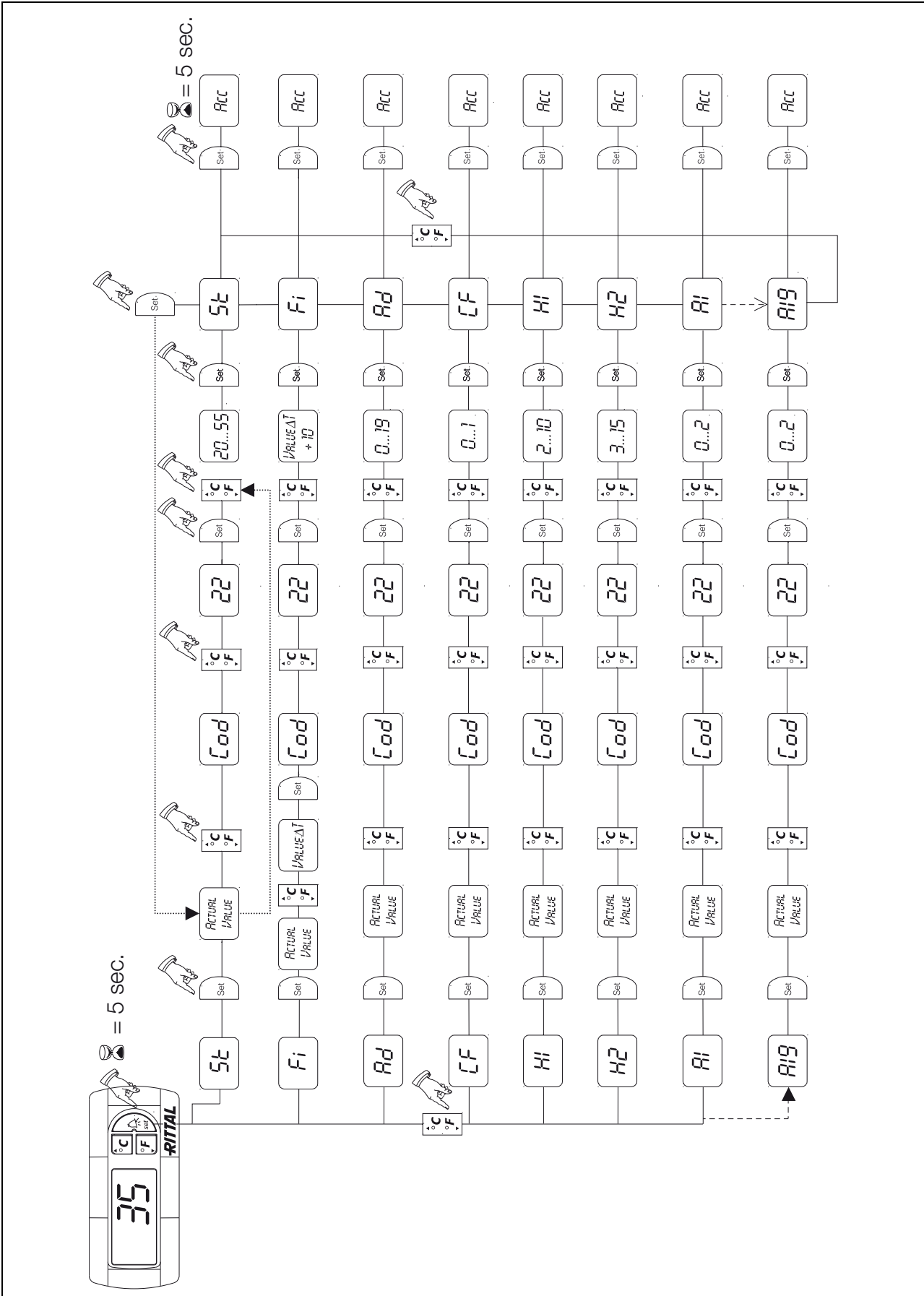

Fig. 16: Programming overview



**6.1.6 Defining system messages for evaluation**

System messages are shown on the display screen of the controller via the displays A1 to A20 and E0.

A more detailed explanation of the system messages

may be found in section “6.1.8 Evaluating system messages”, page 18.

See also fig. 16 on page 16.

Progr. level	Display screen	Min. value	Max. value	Factory setting	Type or location of fault
7	A1	0	2	0	Enclosure door open
8	A2	0	2	0	Internal temperature of enclosure too high
9	A3	0	2	0	Filter monitoring
10	A4	0	2	0	Ambient temperature too high/too low
11	A5	0	2	0	Icing hazard
12	A6	0	2	1	PSA <sup>H</sup> pressure-operated switch
13	A7	0	2	2	Evaporator coil
14	A8	0	2	1	Condensate warning
15	A9	0	2	1	Condenser fan blocked or defective
16	A10	0	2	1	Evaporator fan blocked or defective
17	A11	0	2	2	Compressor
18	A12	0	2	1	Condenser
19	A13	0	2	1	Ambient temperature sensor
20	A14	0	2	1	Icing temperature sensor
21	A15	0	2	1	Condensate warning temperature sensor
22	A16	0	2	1	Internal temperature sensor
24	A18	0	2	0	EPROM
25	A19	0	2	0	LAN/Master-slave

Tab. 4: System messages that can be evaluated via relays

The system messages A1 – A19 may also be evaluated via two floating system message relays. In this way, one of the two system message relays may be allocated to each system message.

System message relays with changeover and normally open contact: See wiring diagram fig. 12 on page 12:

- Terminal 3: NC (normally closed)
- Terminal 4: C (connection of the supply voltage to the system message relay)
- Terminal 5: NO (normally open)

The NC and NO definitions refer to the de-energised state. As soon as power is applied to the cooling unit, the system message relay picks up, so that the relay contacts change status (contact 3 – 4 open; contact 4 – 5 closed). This is the normal operating state of the cooling unit. As soon as a system message occurs or the power supply is interrupted, the relay drops out.

Program system messages with the value

- 0: System message is not sent to the system message relays, but merely appears in the display
- 1: System message is evaluated by relay 1

# 6 Operation

EN

## 6.1.7 Setting the master-slave identifier

When several cooling units are connected together (maximum ten), one of the cooling units must be defined as the “master” and the others as “slaves”. For this purpose, assign a corresponding identifier (address) to each cooling unit which will enable the cooling unit to be identified in the network.

If one of the slave units reaches the set temperature or if the door limit switch function is activated, the affected slave unit will report to the master unit, which then deactivates all the other cooling units.



### Notes:

- Only one unit may be configured as master, and its identifier must match the number of connected slave units.
- The slave units must have different identifiers.
- The identifiers must be numbered in ascending order without any gaps.

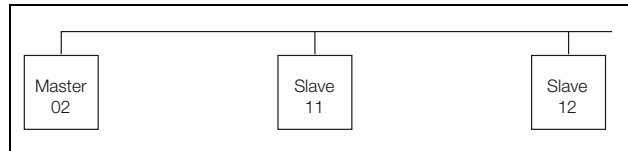

Fig. 17: Master/slave connection (example)

For further connection examples, see “4.6.1 Bus connection”, page 10.

For details of how to set the identifier, see “6.1.4 Editable parameters”, page 15 or “6.1.5 Programming overview”, page 16, parameter “Ad”.

## 6.1.8 Evaluating system messages

In the controller, system messages are indicated by a number in the display.

Following the appearance of messages A03, A06 and A07 and after rectifying their cause, you will need to reset the controller (see “6.1.9 Resetting the controller”, page 20).

On the **master cooling unit** (00 = factory setting), set the number of slave units present in the network:

- 01: Master with 1 slave cooling unit
- 02: Master with 2 slave cooling units
- 03: Master with 3 slave cooling units
- 04: Master with 4 slave cooling units
- 05: Master with 5 slave cooling units
- 06: Master with 6 slave cooling units
- 07: Master with 7 slave cooling units
- 08: Master with 8 slave cooling units
- 09: Master with 9 slave cooling units

On the **slave cooling unit** (00 = factory setting), set its own address:

- 11: Slave cooling unit no. 1
- 12: Slave cooling unit no. 2
- 13: Slave cooling unit no. 3
- 14: Slave cooling unit no. 4
- 15: Slave cooling unit no. 5
- 16: Slave cooling unit no. 6
- 17: Slave cooling unit no. 7
- 18: Slave cooling unit no. 8
- 19: Slave cooling unit no. 9

Display screen	System message	Possible cause	Measures to rectify the fault
A01	Enclosure door open	Door open or door limit switch incorrectly positioned	Close door, position door limit switch correctly, check connection if necessary
A02	Internal temperature of enclosure too high	Cooling capacity inadequate/unit undersized Error as a consequence of messages A03 to A17.	Check cooling capacity
A03	Filter monitoring	Filter mat soiled	Clean or replace; reset the controller
A04	Ambient temperature too high/too low	Ambient temperature outside of admissible operating range (+10°C to +60°C)	Raise or lower the ambient temperature (e.g. heat or ventilate the room)
A05	Icing hazard	Operational display in case of icing hazard. Evaporator coil fan may be mechanically blocked, defective, or cold air outlet obstructed.	Set the enclosure interior temperature to a higher value. Check the evaporator fan; release or exchange if necessary.
A06	PSA <sup>H</sup> pressure switch	Ambient temperature too high	Lower the ambient temperature; reset the controller
		Condenser soiled	Clean the condenser; reset the controller
		Filter mat soiled	Clean or replace; reset the controller
		Condenser fan defective	Replace; reset the controller
		E-valve defective	Repair by refrigeration engineer; reset the controller
A07	Evaporator coil	PSA <sup>H</sup> pressure switch defective	Refrigeration engineer to exchange; reset the controller
		Lack of refrigerant; sensor in front of or behind condenser defective	Repair by refrigeration engineer; reset the controller
A08	Condensate warning	Condensate discharge kinked or blocked	Check condensate drainage; correct any kinks or blockages in the hose
		Only for units with optional condensate evaporation	Check the evaporation unit, exchange if necessary
A09	Condenser fan	Blocked or defective	Clear the blockage; replace if necessary
A10	Evaporator fan	Blocked or defective	Clear the blockage; replace if necessary
A11	Compressor	Compressor overloaded (internal winding protection)	No action required; unit switches on again independently
		Defective (check by measuring the winding resistance)	Replace by refrigeration engineer
A12	Condenser temperature sensor	Open or short-circuit	Replace
A13	Ambient temperature sensor	Open or short-circuit	Replace
A14	Icing temperature sensor	Open or short-circuit	Replace
A15	Condensate warning temperature sensor	Open or short-circuit	Replace
A16	Internal temperature sensor	Open or short-circuit	Replace
A17	Phase monitoring	For three-phase devices only: Incorrect rotary field/phase absent	Swap two phases
A18	EPROM error	New board obstructed	Software update needed (only following board installation with more recent software): Enter the programming level with Code 22; press button 1 and confirm with "Set" until "Acc" appears. Next, disconnect the unit from the mains and reconnect.
A19	LAN/Master-slave	Master and slave not connected	Check setting and/or cable
A20	Voltage drop	Error display not shown	Event is stored in the log file
E0	Display message	Connection problem between the display and the controller board	Reset: Switch power supply off, then switch on again after approx. 2 sec.
		Cable defective; connection loose	Replace the boards

Tab. 5: Troubleshooting with the controller

# 7 Inspection and maintenance

EN

## 6.1.9 Resetting the controller

After the occurrence of faults A03, A06 and A07, you will need to reset the controller.

- Press buttons 1 (▲) and 3 (▼) (fig. 15) simultaneously for 5 seconds.

The system messages will disappear and the temperature display will be shown.

## 7 Inspection and maintenance



**Risk of electric shock!**

**The unit is live.**

**Switch off the power supply before opening, and take suitable precautions against it being accidentally switched back on.**

### 7.1 General

The cooling circuit is designed in the form of a maintenance-free, hermetically sealed system. The cooling unit is filled with the required quantity of refrigerant at the factory, checked for leaks, and subjected to a functional test run.

The installed maintenance-free fans are mounted on ball bearings, protected against moisture and dust, and fitted with a temperature monitor. The life expectancy is at least 30,000 operating hours. The cooling unit is thus largely maintenance-free. All that may be required from time to time is to clean the components of the external air circuit using a vacuum cleaner or compressed air if they become visibly dirty. Any stubborn, oily stains may be removed using a non-flammable detergent, such as degreaser. Maintenance interval: 2,000 operating hours.

Depending on the level of contamination in the ambient air, the maintenance interval may be reduced to suit the air pollution intensity.



**Caution!**

**Risk of fire!**

**Never use flammable liquids for cleaning.**

Sequence of maintenance measures:

- Check the level of dirt.
- Filter soiling? Replace the filter if necessary.
- Cooling membranes soiled? Clean if necessary.
- Activate test mode; cooling function OK?
- Check noise generation of compressor and fans.

### 7.1.1 Compressed air cleaning

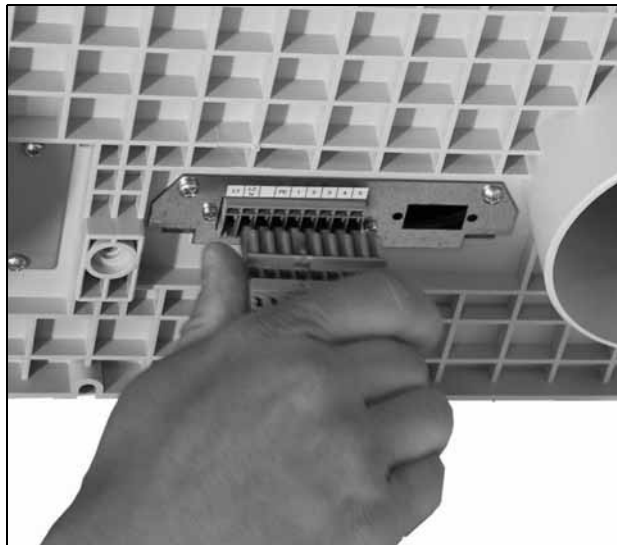

Fig. 18: Disconnect the mains plug



Fig. 19: Release the louvred grille



Fig. 20: Remove the louvred grille

## 7 Inspection and maintenance

EN



Fig. 21: Disconnect the connector from the display



Fig. 24: Remove the cover



Fig. 22: Disconnect the earthing cable



Fig. 25: Cooling unit without cover (front view)



Fig. 23: Remove the assembly screws from the cover (loosen four screws)



Fig. 26: Cooling unit without cover (rear view)

## 8 Storage and disposal

EN



Fig. 27: Clean the heat exchanger coil and compressor chamber using compressed air



Fig. 28: Fit the louvred grille

### 8 Storage and disposal



**Caution! Risk of damage!**

**The cooling unit must not be subjected to temperatures above +70°C during storage.**

During storage, the cooling unit must stand upright. The closed cooling circuit contains refrigerant and oil which must be properly disposed of for the sake of the environment. Disposal can be performed at the Rittal plant.

Please contact us for advice.

## 9 Technical specifications

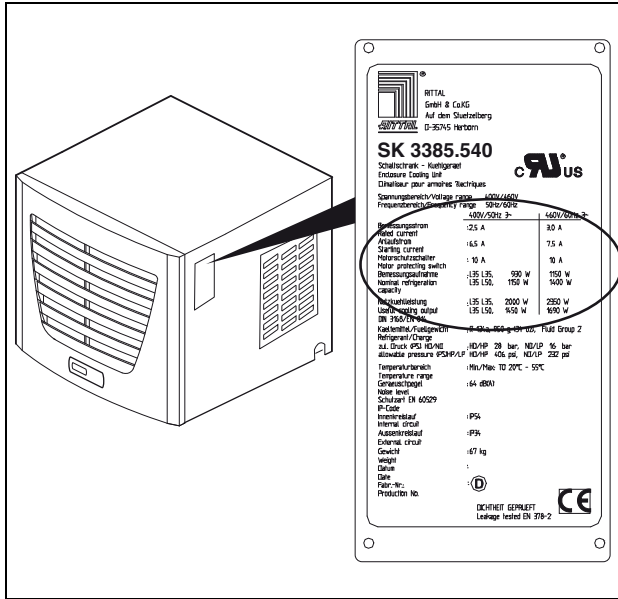

- Observe the mains connection data (voltage and frequency) as per the rating plate.
- Observe the pre-fuse as per the specifications on the rating plate.

Fig. 29: Rating plate (technical data)

	Unit	Model No.	
<b>Comfort controller, RAL 7035</b>	–	<b>3301.800</b>	
Rated voltage	V, Hz	230, 1~, 50	
Rated current	A	10.4	
Start-up current	A	36.0	
Pre-fuse T	A	16.0	
Motor circuit-breaker	–	–	
Transformer circuit-breaker	–	–	
Miniature circuit-breaker	–	■	
Useful cooling output $\dot{Q}_k$ to DIN 3168	L 25 L 35 L 35 L 45	W W	3000 3200
Power consumption $P_{el}$ to DIN 3168	L 25 L 35 L 35 L 45	W W	1820 2325
Refrigerant – Type – Filling	– g		R134a 1200
Admissible pressure	bar		25
Temperature setting range	°C		+20 to +22
Noise level	dB(A)		70
Type of connection	–		Plug-in terminal strip
Protection category to IEC 60 529 – Internal circuit – External circuit	– –		IP 54 IP 24
Dimensions (W x H x D)	mm		597 x 417 x 895
Air throughputs of the fans (unimpeded airflow) – Internal circuit – External circuit	m <sup>3</sup> /h m <sup>3</sup> /h		1450 2000
Weight	kg		96.6

Tab. 6: Technical specifications

# 10 List of spare parts

## 10 List of spare parts

EN

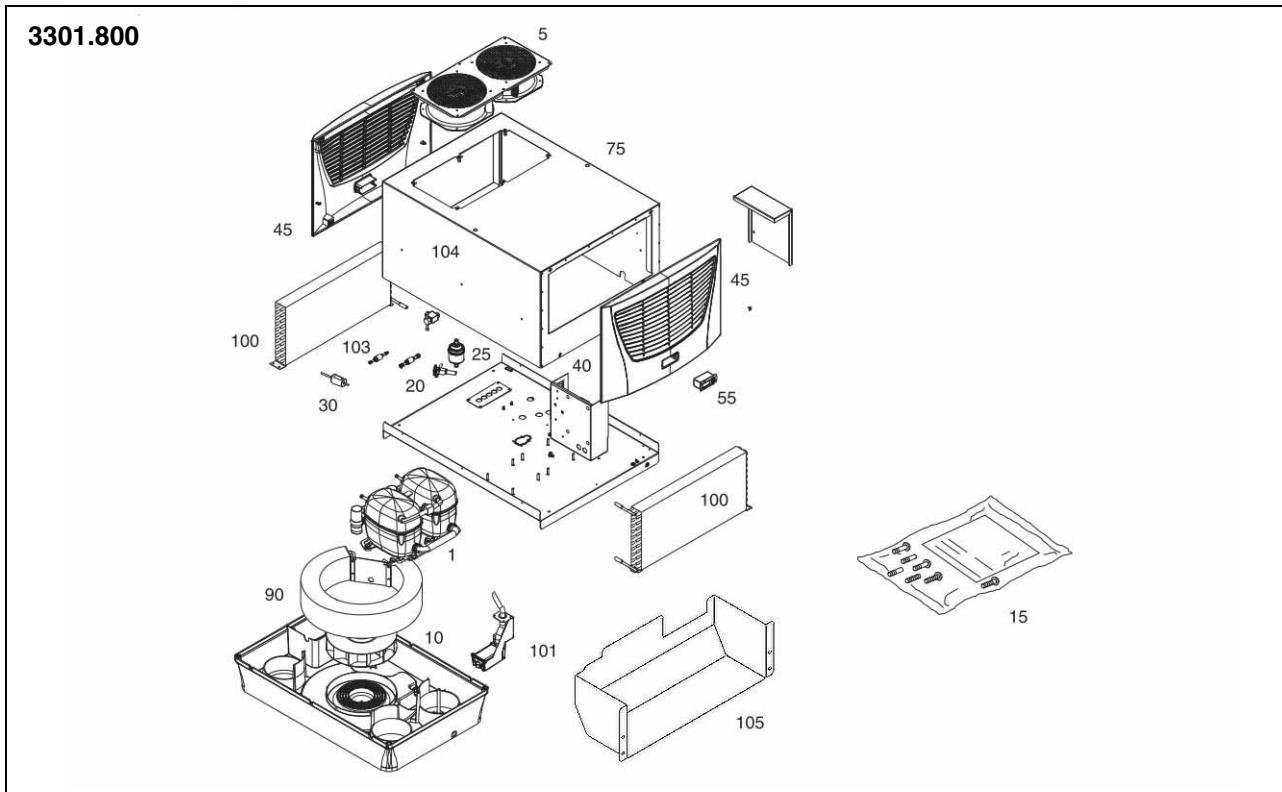

Fig. 30: Spare parts for 3301.800

### Key

- 1 Compressor
- 5 Condenser fan
- 10 Evaporator fan
- 15 Dispatch bag
- 20 Expansion valve
- 25 Filter dryer
- 30 PSA<sup>H</sup> pressure-operated switch
- 40 Controller board
- 45 Louvred grille
- 55 Controller/display
- 71 Temperature sensor
- 75 Enclosure tray
- 80 Transformer
- 90 Evaporator coil
- 100 Condenser
- 101 Condensate evaporator
- 102 Miniature fuse, condensate evaporator
- 103 Non-return valves
- 104 Magnetic valve
- 105 Air baffle plate 19"



### Note:

As well as the spare part number, when ordering spare parts the following information must be provided:

- Unit model
- Fabrication number
- Date of manufacture

This information may be found on the rating plate.

Model numbers of the spare parts may be found on the Internet at:

[www.rittal.com/de\\_de/spare\\_parts](http://www.rittal.com/de_de/spare_parts)



# 11 Appendix: Cut-out and hole sizes

## 11 Appendix: Cut-out and hole sizes

EN

### 11.1 Dimensions for assembly

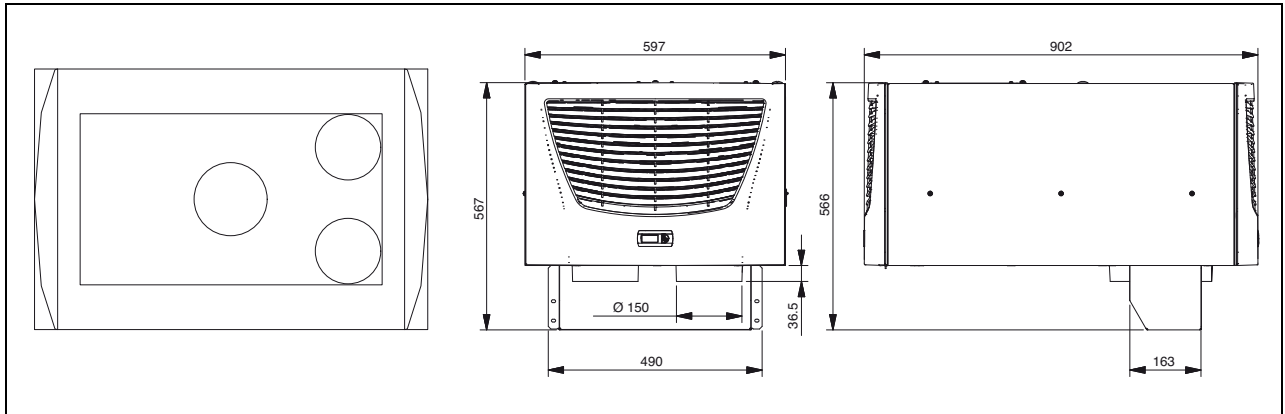

Fig. 31: 3301.800 assembly

# Rittal – The System.

---

**Faster – better – everywhere.**

- Enclosures
- Power Distribution
- Climate Control
- IT Infrastructure
- Software & Services

RITTAL GmbH & Co. KG  
Postfach 1662 · D-35726 Herborn  
Phone +49(0)2772 505-0 · Fax +49(0)2772 505-2319  
E-mail: [info@rittal.de](mailto:info@rittal.de) · [www.rittal.com](http://www.rittal.com)

ENCLOSURES

POWER DISTRIBUTION

CLIMATE CONTROL

IT INFRASTRUCTURE

SOFTWARE & SERVICES



FRIEDHELM LOH GROUP