

Rittal – The System.

Faster – better – everywhere.

Scharnierbefestigung
Hinge attachment
Fixation par charnières



VX 8617.650

Montageanleitung
Assembly instructions
Notice de montage

ENCLOSURES

POWER DISTRIBUTION

CLIMATE CONTROL

IT INFRASTRUCTURE

SOFTWARE & SERVICES

FRIEDHELM LOH GROUP



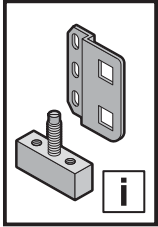

Inhaltsverzeichnis
Contents
Sommaire

DE	Seite	EN	Page	FR	Page
1. Sicherheitshinweise	3 – 6	1. Safety instructions	3 – 6	1. Consignes de sécurité	3 – 6
2. Gerätebeschreibung	7	2. Device description	7	2. Description de l'accessoire	7
2.1 Lieferumfang	7	2.1 Scope of delivery	7	2.1 Composition de la livraison	7
3. Montage	8 – 11	3. Assembly	8 – 11	3. Montage	8 – 11
3.1 Einbausatz für Schwenkrahmen, klein	8	3.1 Installation kit for swing frame, small	8	3.1 Kit de montage pour cadre pivotant petit format	8
3.2 Befestigung Einbausatz, am Profil	9	3.2 Installation kit attachment, to the extrusion	9	3.2 Fixation du kit de montage sur le montant	9
3.3 Befestigung Einbausatz, an System-Chassis	10	3.3 Installation kit attachment, to the punched section with mounting flange	10	3.3 Fixation du kit de montage sur les rails de montage	10
3.4 Einbau Scharnierbefestigung	11	3.4 Installation of hinge attachment	11	3.4 Montage de la fixation par charnières	11

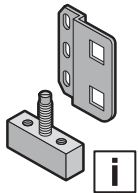

3 – 7

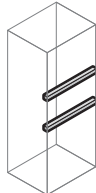

8 – 9

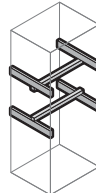

10

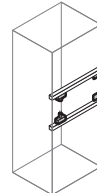

11

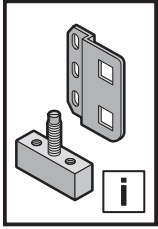

1. Sicherheitshinweise
1. Safety instructions
1. Consignes de sécurité

1. Veiligheidsvoorschriften
1. Säkerhetsinstruktioner
1. Avvertenze di sicurezza

1. Advertencias de seguridad

	DE	EN	FR	NL	SE	IT	ES
	Warnung vor der Schließbewegung von mechanischen Teilen einer Maschine/Einrichtung	Warning against closing movements for mechanical parts of a machine/device	Danger dû à la fermeture de pièces mécaniques d'une machine / installation	Waarschuwing voor de sluitbeweging van mechanische onderdelen van een machine/voorziening	Varning för stängningsrörelse på mekaniska delar i en maskin/enhet	Prestare attenzione alla chiusura delle parti meccaniche di una macchina o di un dispositivo	Atención, movimiento de cierre de componentes mecánicos en una máquina/instalación
	Warnung vor sich bewegenden mechanischen Teilen	Warning against independently moving parts	Danger dû à des pièces mécaniques mobiles	Waarschuwing voor bewegende mechanische onderdelen	Varning för röriga mekaniska delar	Prestare attenzione alle parti meccaniche in movimento	Atención, componentes mecánicos en movimiento
	Warnung vor spitzem Gegenstand	Caution: Sharp object	Attention aux objets pointus	Waarschuwing voor scherp gepunte voorwerpen	Varning för vassa föremål	Pericolo oggetto affilato	Advertencia de objetos puntiagudos
	Warnung vor schweren Lasten	Caution: Heavy loads	Attention aux charges lourdes	Waarschuwing voor zware belastingen	Varning för tung last	Pericolo carichi pesanti	Advertencia de cargas pesadas
	Warnung vor Hindernissen im Kopfbereich	Caution: Obstructions in head area	Attention aux obstacles au niveau de la tête	Waarschuwing voor obstakels op hoofdhoogte	Varning för hinder i huvudhöjd	Pericolo ostacolo in alto	Advertencia de obstáculos en la zona de la cabeza
	Installation durch Mechanik-Fachkraft	Installation by specialist mechanics	Installation par un mécanicien confirmé	Installatie door monteur	Ska installeras av behörig montör	L'installazione deve essere eseguita da un meccanico qualificato	Instalación a realizar por un técnico mecánico cualificado

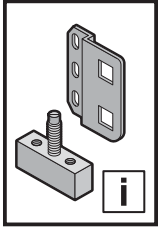

1. Turvallisuusohjeet
1. Sikkerhedsanvisninger
1. Faisnéis sábháilteachta

1. Wskazówki dotyczące bezpieczeństwa
1. Bezpečnostní pokyny

1. Инструкции за безопасност
1. Меры безопасности

	FI	DK	IE	PL	CZ	BG	RU
	Varoitus koneen/ laitteen mekaanisten osien sulkuliikkeestä	Advarsel mod lukkebevægelse af mekaniske dele i en maskine/ indretning	Rabhadh: Gluaiseacht dúnta comhpháirteanna meicniúla meaisín/gléis	Uwaga na zamykające się części mechaniczne maszyny lub urządzenia	Výstraha před rizikem úrazu ruky	Предупреждение за движение от затварящи се механични части на машина/ оборудване	Предупреждение об опасности при закрывании механических частей машины/ установки
	Varoitus liikkuvista mekaanisista osista	Advarsel mod uafhængigt bevægelige dele	Rabhadh: Comhpháirteanna meicniúla gluaisteachta	Uwaga na ruchome części mechaniczne	Výstraha; Rozmačkání	Предупреждение за опасност от движещи се механични части	Предупреждение об опасности движущихся механических частей
	Varo teräviä esineitä	Advarsel: Spidse genstande	Aire: Rud géar	Ostrzeżenie przed ostrym przedmiotem	Varování před ostrým předmětem	Предупреждение за опасност от остър предмет	Предупреждение об остром предмете
	Varo raskasta kuormaa	Advarsel: Tunge belastninger	Aire: Ualalaí tromha	Ostrzeżenie przed dużymi ciężarami	Varování před těžkými břemeny	Предупреждение за опасност от тежки товари	Предупреждение о тяжелых нагрузках
	Varo putoavia esineitä	Advarsel: Forhindringer i hovedhøjde	Aire: Baic i limistéar an chinn	Ostrzeżenie przed przeszkodami w pobliżu głowy	Varování před překážkami v oblasti hlavy	Предупреждение за опасност от препятствия в областта около главата	Предупреждение о препятствиях в верхней области
	Asennuksen saa suorittaa vain mekaniikka-alan ammattilainen	Skal installeres af uddannet mekaniker	Ní cheadaítear ach amháin do meicneoir cáilithe é a shuiteáil	Instalacja przez mechanika	Instalace odborným mechanikem	Монтажът се извършва от механик	Установка силами специалистов по механике

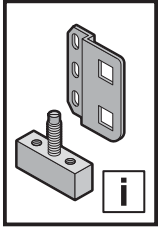

1. Υποδείξεις ασφαλείας
1. Instrucțiuni de siguranță
1. Sigurnosne upute

1. Biztonsági tudnivalók
1. Saugos nurodymai
1. Ohutusteatis

1. Drošības prasības

	GR	RO	HR	HU	LT	EE	LV
	Προειδοποίηση πριν από την κίνηση κλειδώματος μηχανικών μερών μίας εγκατάστασης/μηχανήματος	Avertizare cu privire la mișcarea de închidere a pieselor mecanice ale unei mașini/ale unui dispozitiv	Upozorenje na uklopno kretanje mehaničkih dijelova stroja/uređaja	Gép/berendezés mechanikai részeknek zárómozgására történő figyelmeztetés	Įspėjimas dėl mašinos / įrenginio mechaninių dalių judėjimo, užsidarymo metu	Hoiatus masina/ seadme mehhaaniliste osade sulgemisliikumise eest	Uzmanieties iekārtas/mašīnas mehānisko daļu aizvēršanās laikā
	Προειδοποίηση από κινούμενα μηχανικά μέρη	Avertisment cu privire la piesele mecanice aflate în mișcare	Upozorenje na mehaničke dijelove koji su u pokretu	Mozgó mechanikai részekre történő figyelmeztetés	Įspėjimas dėl judančių mechaninių dalių	Hoiatus liikuvate mehhaaniliste osade eest	Uzmanieties no kustīgām mehāniskām daļām
	Προειδοποίηση αιχμηρού αντικειμένου	Avertizare privind obiecte ascuțite	Upozorenje na šiljati predmet	Figyelmeztetés hegyes tárgyak veszélyére	Įspėjimas apie aštrų daiktą	Hoiatus terava eseme eest	Brīdinājums par asiem priekšmetiem
	Προειδοποίηση για βαριά φορτία	Avertizare privind sarcini grele	Upozorenje na teške terete	Figyelmeztetés nehéz teherre	Įspėjimas apie sunkius krovinius	Hoiatus raskete koormate eest	Brīdinājums par lielu slodzi
	Προειδοποίηση για εμπόδια στην περιοχή της κεφαλής	Avertizare privind obstacole în zona capului	Upozorenje na zapreke u području glave	Figyelmeztetés fejmagasságban található akadályokra	Įspėjimas apie kliūtis galvos aukštyje	Hoiatus pea piirkonnas asuvate takistuste eest	Brīdinājums par šķēršļiem galvas zonā
	Εγκατάσταση από εκπαιδευμένο μηχανικό	Instalarea se va face de un mecanic calificat	Instalaciju smije provesti samo ovlašteno stručno osoblje za mehaničarske radove	A szerelését mechanikus szakembernek kell elvégeznie	Turi įrengti mechanikas	Kvalifitseeritud mehhaaniku poolne paigaldamine	Uzstādīšanu drīkst veikt tikai kvalificēts mehāniķis

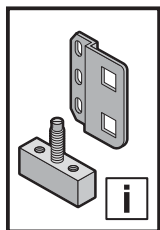

1. Varnostni napotki
1. Bezpečnostné pokyny
1. Instruções de segurança





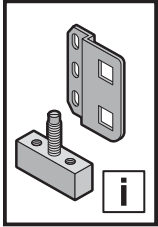

1. Struzzjonijiet ta' prekawzjoni

	SI	SK	PT	MT
	Opozorilo pred zapiranjem mehanskih delov stroja/naprave	Dávajte pozor na zatvárací pohyb mechanických částí stroja/zariadenia	Cuidado quando as partes mecánicas de uma máquina/instalação se fecham	Twissija dwar l-gheluq ta' partijiet mekkaniċi ta' magna/taghmir
	Opozorilo pred premikajočimi se mehanskimi deli	Dávajte pozor na pohyblivé mechanické části	Cuidado com as partes mecánicas móveis	Twissija dwar partijiet mekkaniċi li jiċċaqlqu
	Opozorilo pred ostrim predmetom	Varovanie pred predmetom s ostrým hrotom	Cuidado com objetos pontiagudos	Twissija kontra oġġett bil-ponta
	Opozorilo pred težkimi bremenami	Varovanie pred ťažkými bremenami	Cuidado com cargas pesadas	Twissija kontra taghbijiet tqal
	Opozorilo pred ovirami v višini glave	Varovanie pred prekážkami v priestore hlavy	Cuidado com objetos na altura da cabeça	Twissija kontra ostakoli fiż-żona prinċipali
	Namestitev lahko izvajajo samo usposobljeni strokovnjaki za mehanična dela	Inštaláciu smie vykonávať len špecializovaný mechanik	A instalação deve ser feita por um técnico mecânico especializado	Installazzjoni minn mekkaniku kwalifikat/a



2. Gerätebeschreibung
2. Device description
2. Description de l'accessoire

2.1 Lieferumfang / 2.1 Scope of delivery / 2.1 Composition de la livraison

Best.-Nr. VX Model No. VX Référence VX	8617.650	
		2 x
		2 x
	M5 x 12	4 x
	ST5,5 x 13	4 x
	M8	2 x
	M8	1 x
	M8	2 x

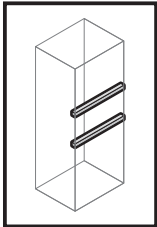

TX25/30



SW7/13



DE EN FR

3. Montage
3. Assembly
3. Montage



3.1 Einbausatz für Schwenkrahmen, klein
3.1 Installation kit for swing frame, small
3.1 Kit de montage pour cadre pivotant petit format

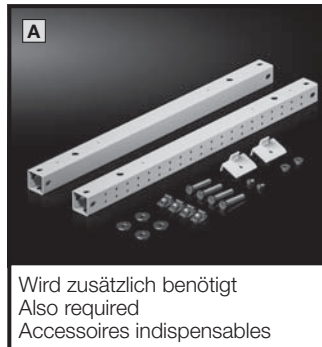
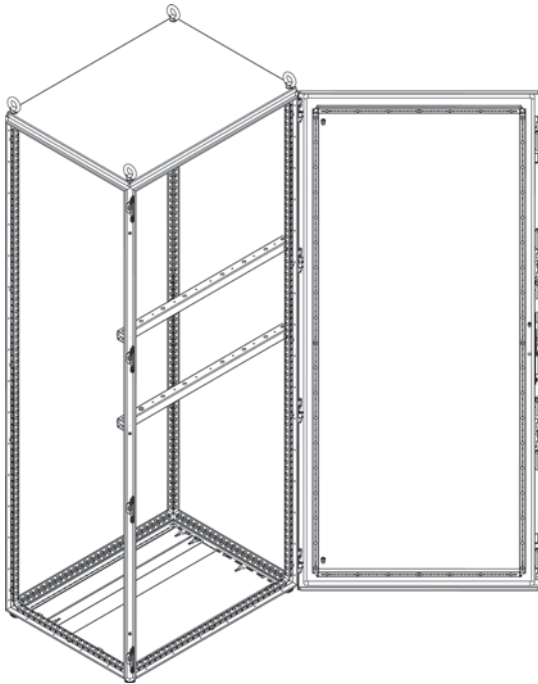

Wird zusätzlich benötigt
 Also required
 Accessoires indispensables

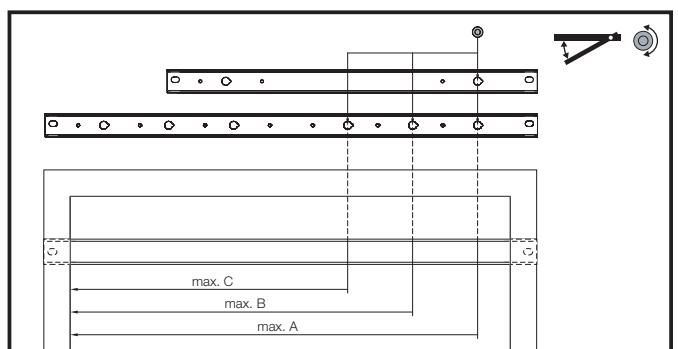
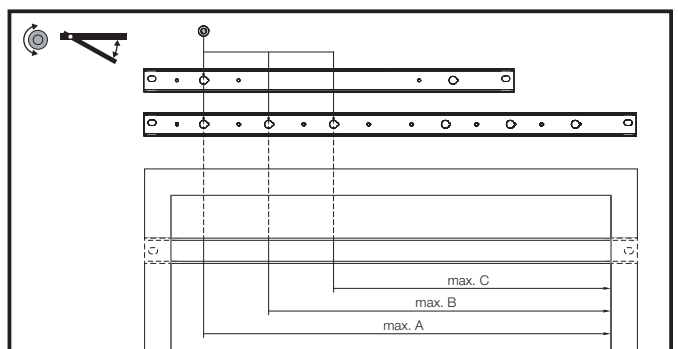
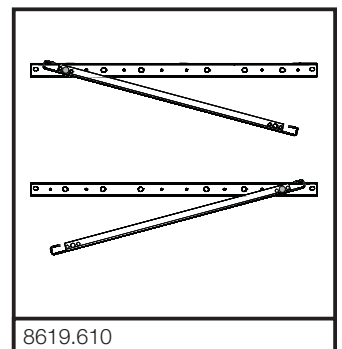
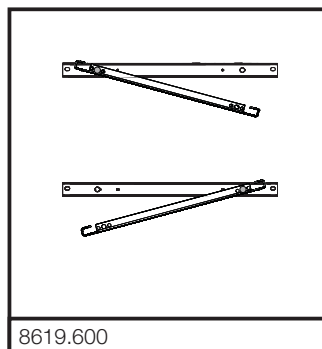
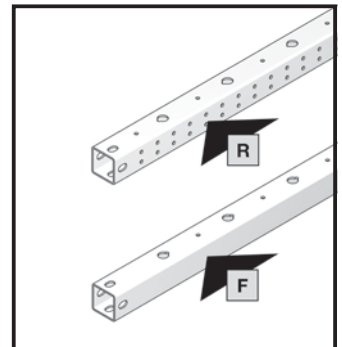

A Einbausatz für Schwenkrahmen, klein
 Installation kit for swing frame, small
 Kit de montage pour cadre pivotant petit format

Für Schrankbreite mm For enclosure width mm Pour largeur d'armoire mm	A	B	C	Best.-Nr. VX Model No. VX Référence VX
600	500	-	-	8619.600
800	700	500	500	8619.610

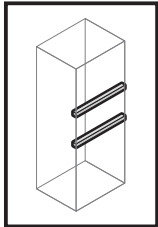

TX30

SW13

DE EN FR

3. Montage
3. Assembly
3. Montage



3.2 Befestigung Einbausatz, am Profil
3.2 Installation kit attachment, to the extrusion
3.2 Fixation du kit de montage sur le montant

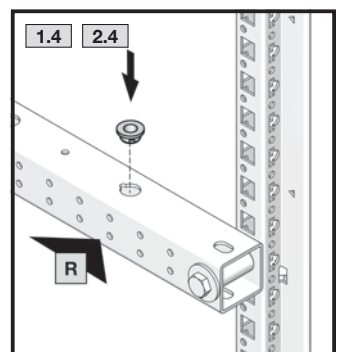
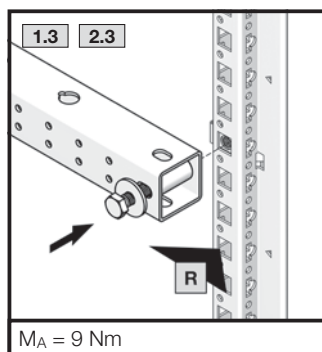
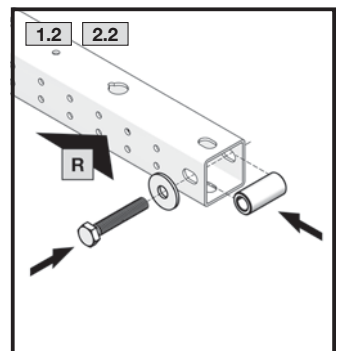
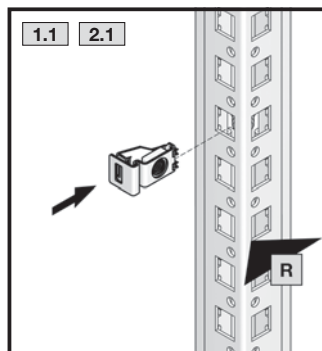
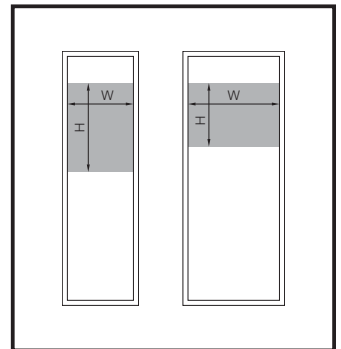
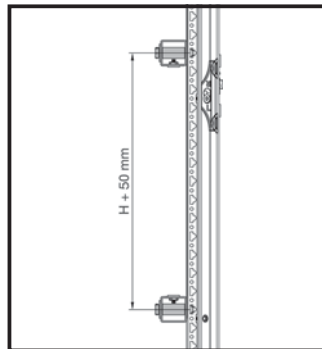
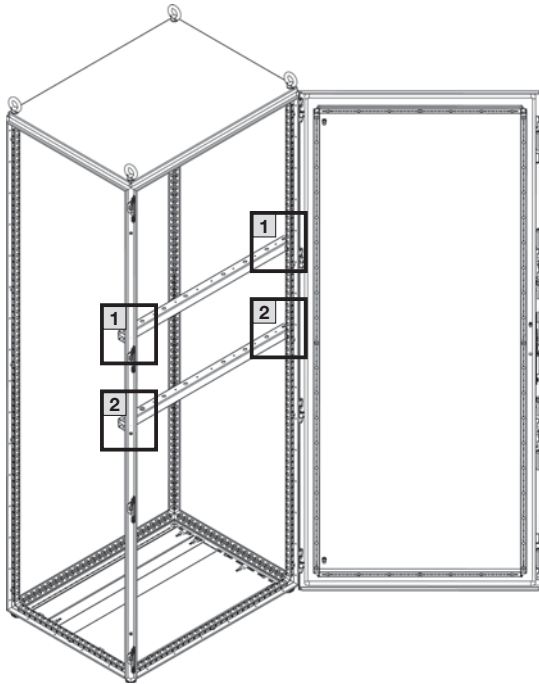

$M_A = 9 \text{ Nm}$

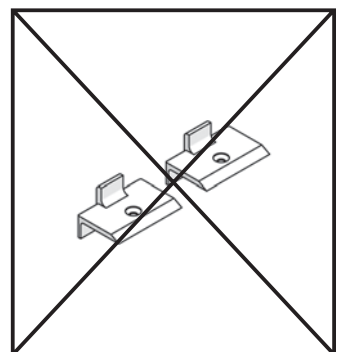
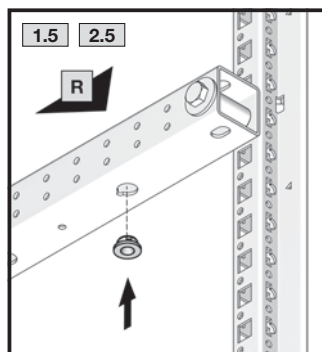

W x H mm	Best.-Nr. Model No. Référence
500 x 300	VX 8617.510
500 x 400	VX 8617.520
500 x 500	VX 8617.530
500 x 700	VX 8617.540
500 x 775	VX 8617.550
700 x 300	VX 8617.560
700 x 400	VX 8617.570
700 x 700	VX 8617.580
900 x 300	VX 8617.590
900 x 400	VX 8617.600
900 x 500	VX 8617.610
1100 x 300	VX 8617.620
1100 x 400	VX 8617.630
1100 x 500	VX 8617.640

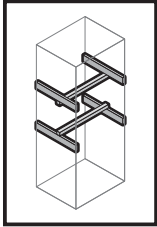

TX30

SW13

DE EN FR

3. Montage
3. Assembly
3. Montage



3.3 Befestigung Einbausatz, an System-Chassis
3.3 Installation kit attachment, to the punched section with mounting flange
3.3 Fixation du kit de montage sur les rails de montage

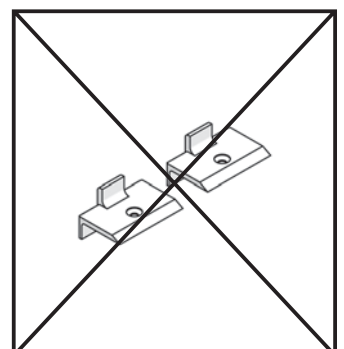
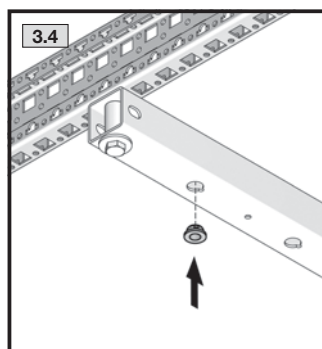
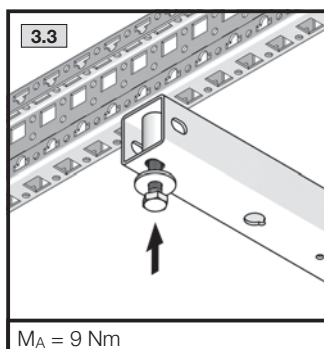
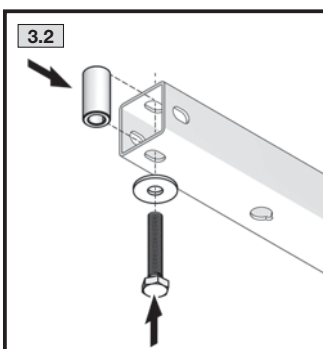
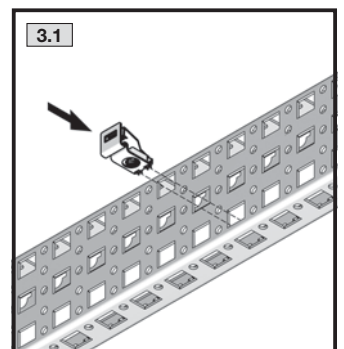
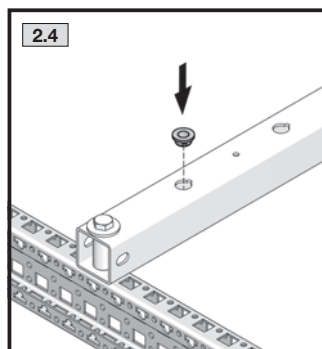
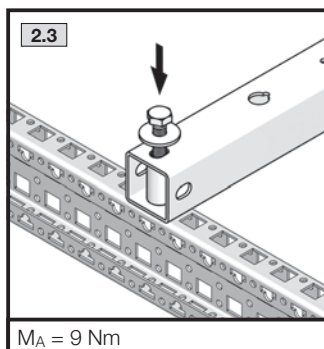
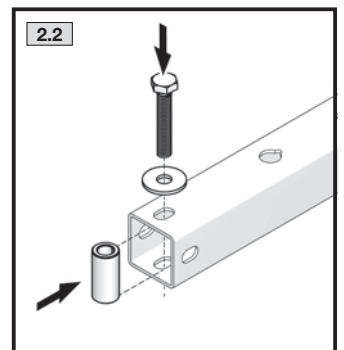
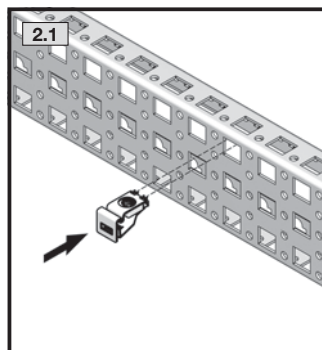
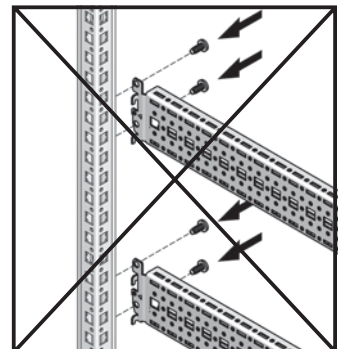
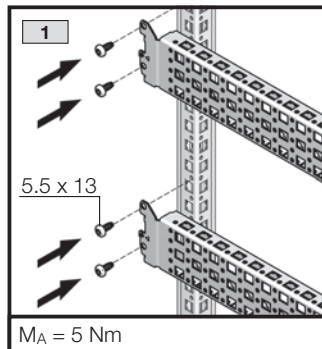
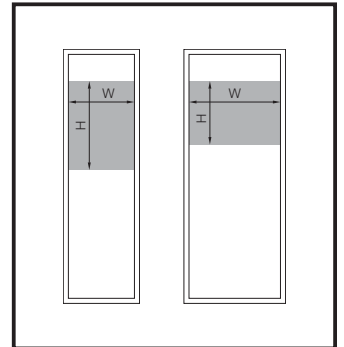
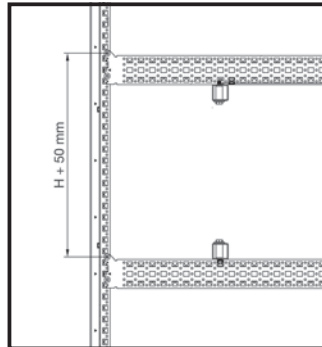
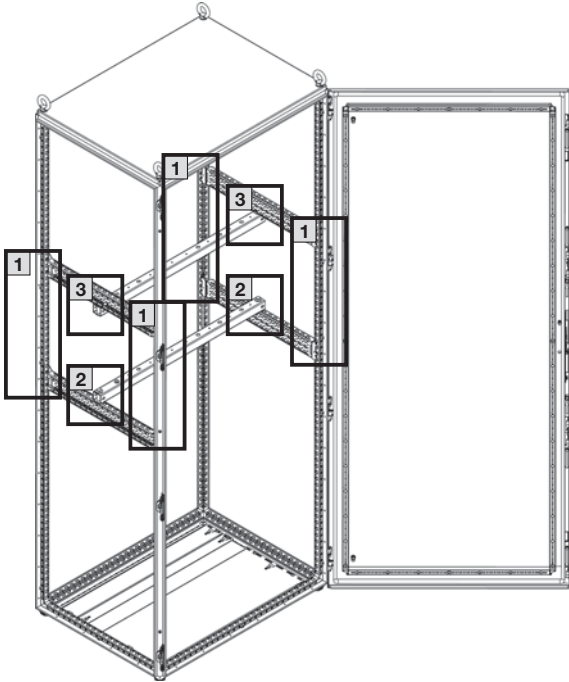

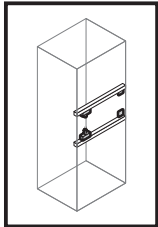

TX30



SW13



DE EN FR

3. Montage
3. Assembly
3. Montage



3.4 Einbau Scharnierbefestigung
3.4 Installation of hinge attachment
3.4 Montage de la fixation par charnières

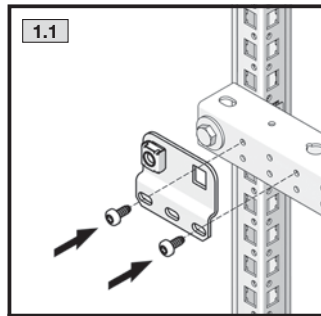
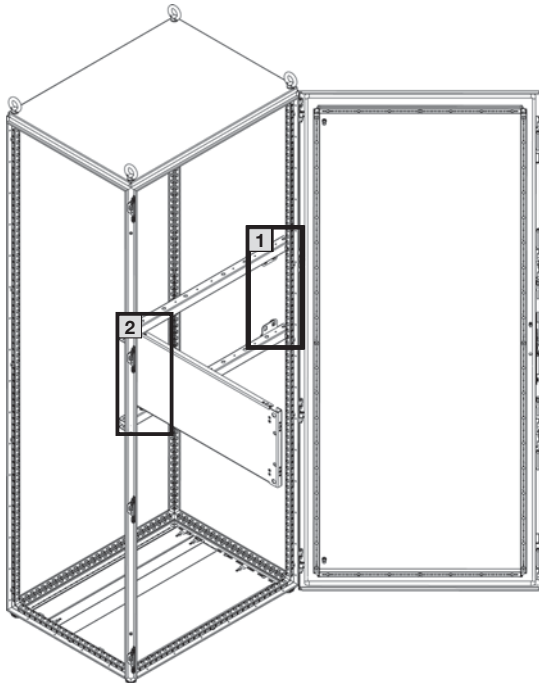

1.1

$M_A = 5 \text{ Nm}$

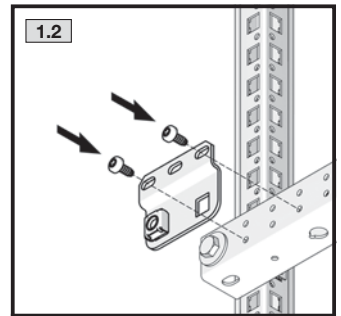

1.2

$M_A = 5 \text{ Nm}$

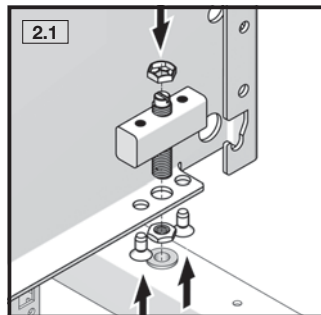

2.1

$M_A = 5 \text{ Nm}$

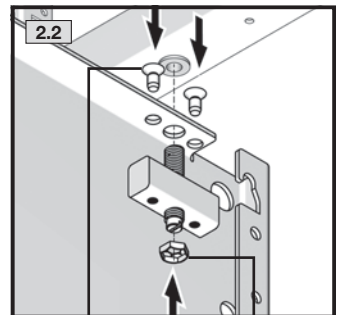

2.2

$M_A = 5 \text{ Nm}$

$M_A = 9 \text{ Nm}$

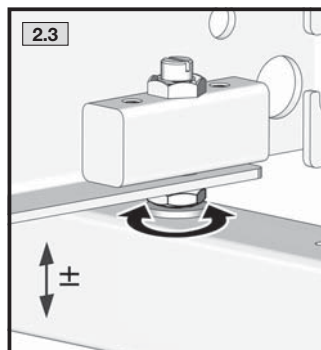

2.3

±

Rittal – The System.

Faster – better – everywhere.

- Enclosures
- Power Distribution
- Climate Control
- IT Infrastructure
- Software & Services

You can find the contact details of all Rittal companies throughout the world here.



www.rittal.com/contact

RITTAL GmbH & Co. KG
Postfach 1662 · D-35726 Herborn
Phone +49(0)2772 505-0 · Fax +49(0)2772 505-2319
E-mail: info@rittal.de · www.rittal.com

06.2018/000000/D-0000-00001549REV00

ENCLOSURES

POWER DISTRIBUTION

CLIMATE CONTROL

IT INFRASTRUCTURE

SOFTWARE & SERVICES



FRIEDHELM LOH GROUP