

Rittal – The System.

Faster – better – everywhere.

Busbar machining, mobile CW 120-M



4055.800

Operating instructions

ENCLOSURES

POWER DISTRIBUTION

CLIMATE CONTROL

IT INFRASTRUCTURE

SOFTWARE & SERVICES

FRIEDHELM LOH GROUP



Foreword

Dear Customer,

We thank you for choosing our Rittal product. Read these operating instructions carefully before using your new unit for the first time and retain them together with the supplied Product Control Card so they can be consulted when required.

We wish you every success.

Kind regards
Rittal GmbH & Co. KG

Rittal GmbH & Co. KG
Auf dem Stützelberg

35745 Herborn
Germany

Tel.: +49(0)2772 505-0
Fax: +49(0)2772 505-239

E-mail: info@rittal.com
www.rittal.com

We are always happy to answer any technical questions regarding our entire range of products.

Contents

1	CE labelling	4
2	Safety instructions	4
2.1	Symbols in these operating instructions	4
2.2	Symbols on the unit	4
2.3	General safety instructions	5
2.4	Personal protective equipment.....	6
2.5	Residual risks when using the unit	6
3	Proper usage	6
4	Scope of supply	7
5	Technical specifications	7
6	Available accessories	8
7	Unit description	8
8	Commissioning	11
9	Bending busbars	13
10	Punching holes in the busbars	15
11	Cutting busbars	18
12	Replacing the cutting blade	19
13	Maintenance and inspection	21
14	Dismantling and disposal	23
15	Contacts	23

1 CE labelling

Rittal GmbH & Co. KG hereby confirms that the "Busbar machining, mobile" is compliant with the Machinery Directive 2006/42/EC and the EMC Directive 2014/30/EU. An appropriate declaration of conformity has been issued. It can be found at the end of this document, on the Rittal Homepage or accompanies the unit as separate document.

2 Safety instructions

2.1 Symbols in these operating instructions

The following symbols are used in this documentation:



Warning!

A hazardous situation which may lead to death or serious injury if the instructions are not followed.



Caution!

Hazardous situation which may lead to (minor) injuries if the instructions are not followed.



Note:

Important notices and indication of situations which may result in material damage.

- This symbol indicates an "action point" and shows that you should perform an operation or work step.

2.2 Symbols on the unit

The following symbols are attached to the unit.



Warning of laser radiation.



Risk of small particles being ejected.



Risk of being crushed or cut by swinging workpieces.



Risk of being crushed or cut by moving unit components.



Observe the operating instructions.



Wear safety goggles.



Maximum dimensions of workpieces.

2.3 General safety instructions

When working with high-pressure hydraulic units, improper handling and/or poor maintenance can damage the unit and cause severe injuries. Consequently, observe all the following safety instructions and contact our service team should you have any questions.

Caution...

- ... when handling hydraulic oil. The oil can become very hot after longer operation. There is a risk of injury!
- Long busbars can swing backwards quickly and unexpectedly when being bent. Ensure that nobody is present in the work area. Risk of injury!
- To extend the service life of the unit, the hydraulic cylinder should not travel to the limit stop under full pressure.
- Risk of environmental contamination! Collect any escaped hydraulic oil and prevent it from entering the sewer system or the surface and ground water.

Always...

- ... machine busbars made of copper or aluminium.
- ... position busbars centred and perpendicular in the unit.
- ... remove objects and foreign bodies from the work area.
- ... position busbars centred to the load piston so that the bending die does not skew.
- ... observe the maximum permitted dimensions of the workpieces.
- ... support long busbars appropriately to prevent them from tilting.
- ... inspect electrical and hydraulic connection lines for damage before deploying the unit.
- ... ensure the secure footing of the unit.
- ... observe the information contained in the operating instructions.
- ... instruct new users in the safe use of the unit.
- ... wear safety goggles when working with the unit.
- ... observe the local, country-specific regulations.
- ... store and deploy the unit in dry and well ventilated spaces.

Never...

- ... deploy the unit when parts are damaged or missing.
- ... make any changes to the unit or remove the warning signs.
- ... intervene in the work area of the tools or the swivel area of the workpieces.
- ... look intentionally and directly at the laser light.
- ... open couplings under pressure.
- ... apply pressure to unconnected hose couplings.
- ... exceed the maximum operating pressure.
- ... operate the unit unattended.
- ... subject the unit to corrosive materials.
- ... deploy the unit unless the operating instructions have been read and understood completely.
- ... store or operate the unit at temperatures above 45 °C (113 °F).

- ... deploy the unit in an explosion risk area.

2.4 Personal protective equipment

The operating and maintenance personnel must always wear personal protective equipment when working on the unit. The personal protective equipment comprises at least the following components:

- Safety work shoes: for all work on the unit
- Safety goggles: for all work on the unit
- Gloves: for loading and unloading the unit

2.5 Residual risks when using the unit

There is the risk of oil escaping from the pump when the unit is transported horizontally or has been tilted excessively.

- When transporting the unit, ensure that it always remains upright.

During operation there is the risk that a hydraulic hose bursts or a screw fastening leaks that can result in oil escaping at high pressure.

- Wear your personal protective equipment for all work performed on the unit (see section 2.4 "Personal protective equipment").

There is the risk that small particles escape at high speed from the machining area (e.g. the shattering of the rubber wiper when punching holes, the breakage of tools or an incorrect tool combination when punching holes).

- Wear your personal protective equipment for all work performed on the unit (see section 2.4 "Personal protective equipment").

Because of its heavy weight, there is the risk of being crushed between the tools and the unit main body when mounting the bending die or the bending mandrel.

- Set up the unit with the necessary care and observe the maximum permitted lifting weights for persons.

If the unit machines busbars made of an impermissible material or from an excessively thick material, there is the risk of the tools becoming damaged and tool parts splitting off.

- Perform machining on materials only in accordance with the proper usage (see section 3 "Proper usage") and the technical specifications (see section 5 "Technical specifications").

If long busbars are machined with the unit, there is the risk that they fall off the machining carriage.

- Support long busbars with a suitable, stable support to prevent unwanted tilting and so prevent the risk of injury.

3 Proper usage

The "Busbar machining, mobile CW 120-M" (Model No. 4055.800) is a mobile work station with several single-acting high-pressure hydraulic cylinders for bending, hole punching and cutting of copper or aluminium busbars with a maximum width of 120 mm and a maximum thickness of 12 mm. The unit is not suitable for machining construction steel or tool steel. An integrated high-pressure hydraulic pump serves as drive for the individual machining stations of the "Busbar machining, mobile".

4 Scope of supply

Scope of supply

Busbar machining, mobile CW 120-M (4055.800)

Foot-operated switch

Bending tool

Operating instructions

Tab. 1: Scope of supply

5 Technical specifications

Technical specifications	
Model No. and designation	4055.800 Busbar machining, mobile CW 120-M
Max. pressure	700 bar (10150 psi)
Max. compressive force	230 kN (52200 lbs)
Max. delivery rate	1.95 l/min (0.5 gal/min). Side hydraulic outlet limited to 1.0 l/min.
Permissible materials	Copper, aluminium
Max. busbar width	120 mm (4.72")
Max. busbar height	12 mm (0.47")
Min. hole diameter (punching)	<ul style="list-style-type: none"> – Ø 6.6 mm for 0... 5 mm material thickness – Ø 9.0 mm for 0... 6 mm material thickness – Ø 11 mm for 0... 12 mm material thickness
Max. hole diameter (punching)	Ø 21.5 mm for 0... 12 mm material thickness
	Min. 50 mm (2")
	Min. 100 mm (4")
Point laser (bending) Line laser (cutting)	0.4 mW, Class 1 laser; MTBF>10,000 h 4.0 mW, Class 1 laser; MTBF>10,000 h
Weight	390 kg (858 lbs)
Min. product dimensions (W x H x D)	1380 mm x 1270 mm x 945 mm (54.3" x 50.0" x 37.2")
Mains connection	230 V, 50/60 Hz
Max. power consumption	2500 W, $I_{max} = 10.9$ A

Tab. 2: Technical specifications

6 Available accessories

Available accessories	Model No.
Hydraulic cylinder	4055.806
Hydraulic hose (3 m)	4055.807
Male die, round	4055.740 – 4055.750
Female dies, round	4055.770 – 4055.780
Male and female dies for slots and special accessories	4055.791

Tab. 3: Available accessories

7 Unit description

The "Busbar machining, mobile" CW 120-M is a multifunctional work station equipped with multiple single-acting hydraulic cylinders for the bending, hole punching and cutting of busbars. The hydraulic pressure is produced by an integrated radial piston pump. The pump produces with maximum pressure of 700 bar a work force of approximately 23 tons.

The single-pedal safety foot-operated switch is connected to the "Busbar machining, mobile" via a socket (fig. 1, 4). Four push-buttons (fig. 1, 8, 12, 13 and fig. 2, 19) serve to select the desired machining station. Machining is possible on only one station. The cutting unit (fig. 1, 15) for shortening busbars as well as the bending and hole-punching unit (fig. 1, 16) are surrounded by a stable, abrasion-resistant table top (fig. 1, 1) made of stainless steel. The table top has an integrated limit stop that can be extended to 1200 mm (fig. 2, 26) for use by all work stations.

An additional hydraulic connection (fig. 1, 5) permits the connection of external hydraulic units to augment the existing work stations. To simplify the machining of long workpieces, the "Busbar machining, mobile" is equipped with an extendible support roller (fig. 1, 7).

Two emergency stop switches (fig. 1, 14 and fig. 2, 18) can stop the hydraulic pump immediately in dangerous situations and allow the tool to be returned to its initial position. The deployment of a frequency converter allows the travel speed of the tools to be set using a potentiometer (fig. 1, 10). During hole cutting and punching, the main body is protected with a stable safety protection hood (fig. 1, 17). The height of the main body can be adjusted easily with a rotary knob (fig. 1, 9) in accordance with the display for the height setting. Four lockable, large drawers (fig. 1, 2) offer sufficient storage space for the deployed tools and work aids. A collection vessel for copper scraps is located behind the door (fig. 2, 21) next to the electric switch cabinet (fig. 2, 22). The mains cable (fig. 2, 23) is embedded in the side panel of the "Busbar machining, mobile" and, when required, can be extended to the maximum length of 4.5 m or rolled in completely.

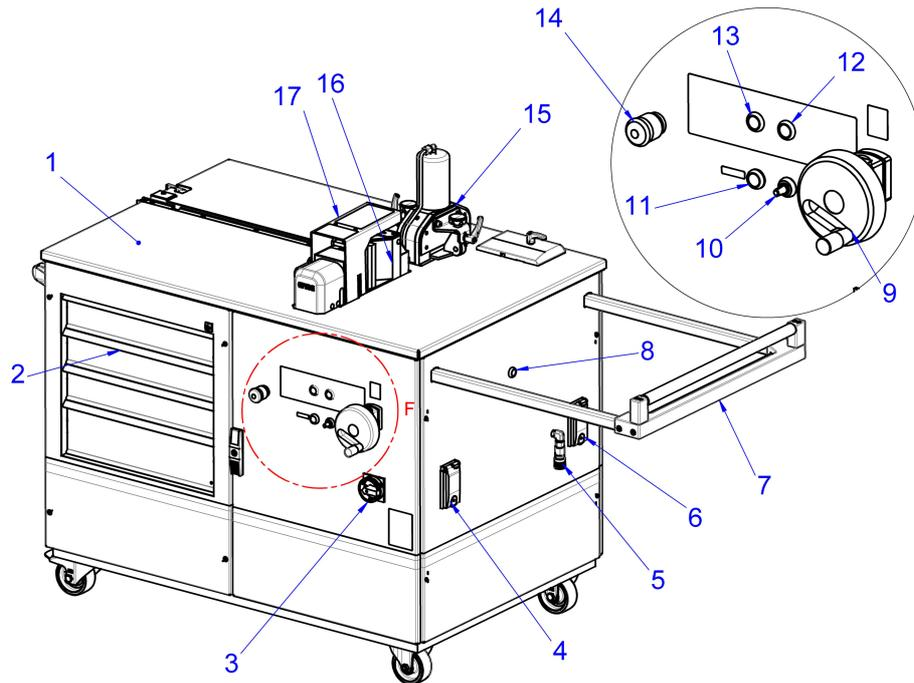

Fig. 1: Front view

Legend

- 1 Table top
- 2 Lockable drawer
- 3 Master switch
- 4 Connection for foot-operated switch (4-pole)
- 5 Hydraulic connection (700 bar) for additional units
- 6 Socket (230 V)
- 7 Extendible support roller
- 8 Selection push-button for additional hydraulic connection (external units)
- 9 Rotary knob for height adjustment
- 10 Potentiometer for speed control
- 11 ON/OFF push-button for point laser (bending)
- 12 Hole cutting selection push-button
- 13 Bending selection push-button
- 14 Emergency stop switch
- 15 Busbar cutting unit
- 16 Busbar bending and hole punching unit
- 17 Protective hood

7 Unit description

EN

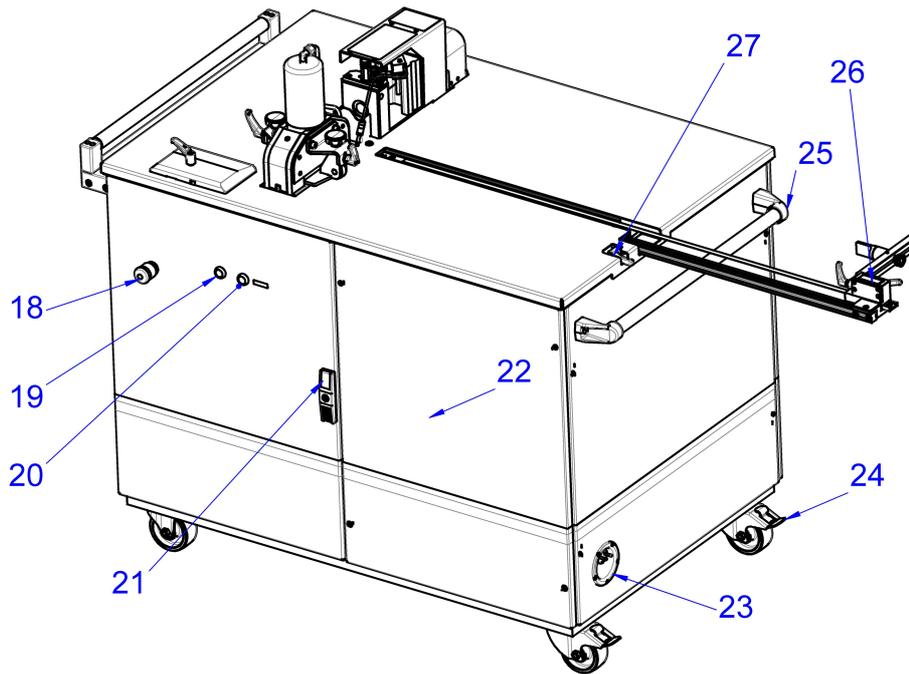

Fig. 2: Rear view

Legend

- 18 Emergency stop switch
- 19 Cutting selection push-button
- 20 ON/OFF push-button for line laser (cutting)
- 21 Door for removing the copper scraps
- 22 Electric switch cabinet
- 23 Extendible mains plug (230 V)
- 24 Rotary and lockable rollers
- 25 Handle
- 26 Extendible limit stop
- 27 Lock for limit stop

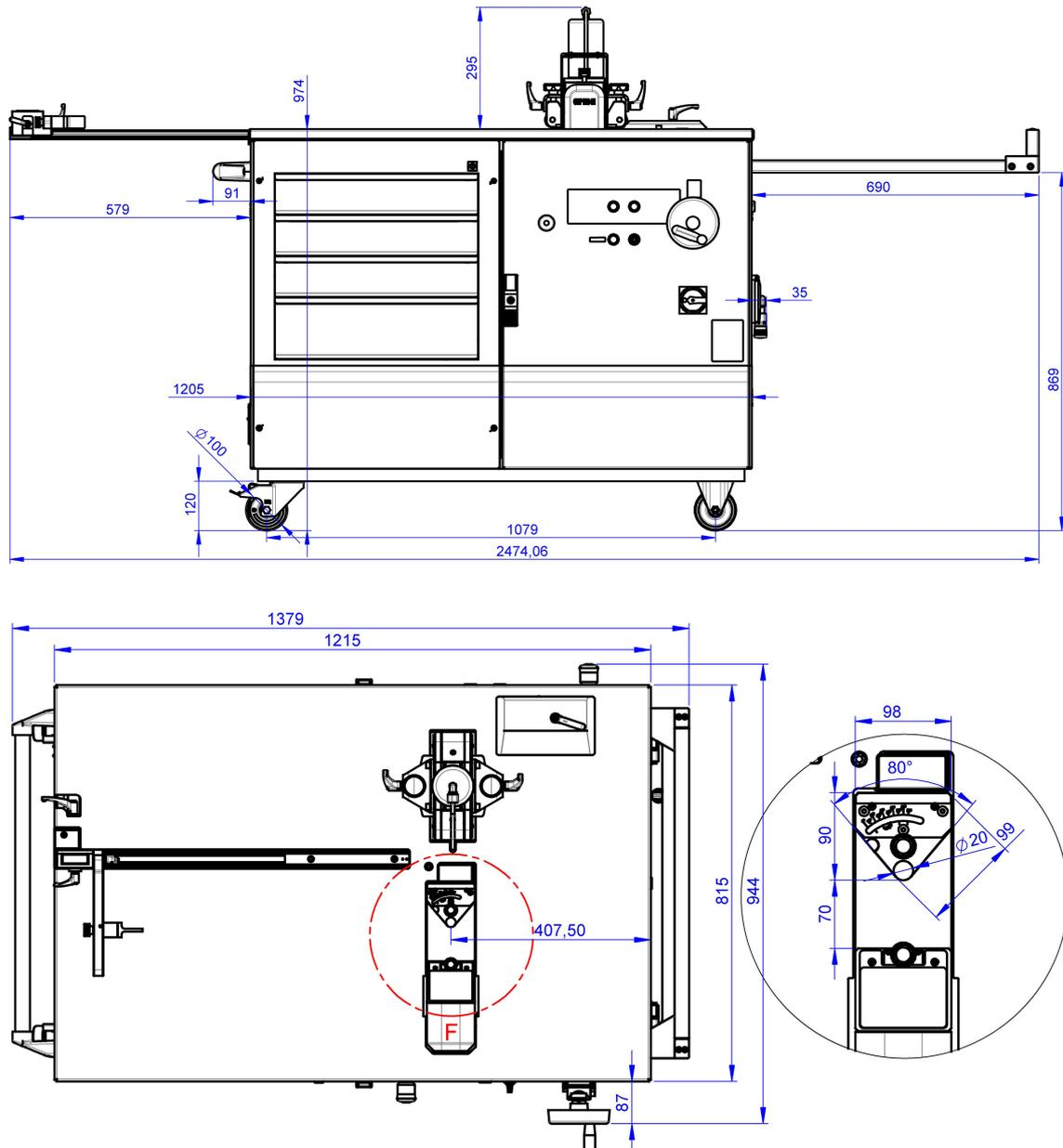

Fig. 3: Dimensions

8 Commissioning

You receive a fully mounted "Busbar machining, mobile" as well as detailed operating instructions.

- On receiving the goods, check them for possible transport damage and the delivery for completeness (see section 4 "Scope of supply").
- In the event of problems, contact the manufacturer or your vendor without delay.
- In any case, read the complete operating instructions as well as all supplied documents before commissioning.



Caution!

There is a risk of injury when lifting the unit in its packaging or if the lifted unit falls (total weight approx. 390 kg).

- Please note the maximum weights that may be lifted by persons. It may be necessary to use lifting gear.
- Do not stand below the lifted unit.



Caution!

When recommissioning the unit, there is the risk that incorrect storage or missing corrosion protection can block unit components and so cause dangers.

■ **Before recommissioning, ensure the smooth running of all components and the correct function of all safety equipment (see section 13 "Maintenance and inspection").**

- Wear your personal protective equipment, in particular gloves and safety work shoes, also for the transport and installation of the unit (see section 2.4 "Personal protective equipment").
- Ensure that the surface on which the unit is placed is flat and sufficiently stable.
- Lock the rollers of the "Busbar machining, mobile" at the installation location to ensure the safe standing of the unit and to prevent an (inadvertent) movement of the unit.
- Inspect the mains cable and plug of the unit for damage. Do not use the unit should there be any damage!
- Extend the mains cable to the required length and insert in the mains plug.
- Then insert the supply cable of the foot-operated switch in the 4-pole connector (fig. 1, 4).
- Set the mains switch of the "Busbar machining, mobile" at (I) to place the unit in ready mode.

The controller requires approx. 5 seconds until it is operational and the individual stations can be selected.



Warning!

If a dangerous situation occurs when working with the unit, stop all dangerous movements of the unit without delay.

■ **In a dangerous situation, press one of the red emergency stop switches (14, 18) on the unit to stop the work operation!**

■ **As an alternative, press the foot-operated switch beyond the first pressure point. This also causes the work operation to stop immediately.**

After triggering an emergency stop:

- Turn the emergency stop switch lightly so that it returns to its initial position. The unit is returned to ready mode. The controller requires approx. 5 seconds until it is operational and the individual stations can be selected. After activating the foot pedal, the hydraulic can be activated again.
- If the emergency stop was activated via the foot-operated switch: release the foot-operated switch by pressing the blue silicone cover at the side (see fig. 4).

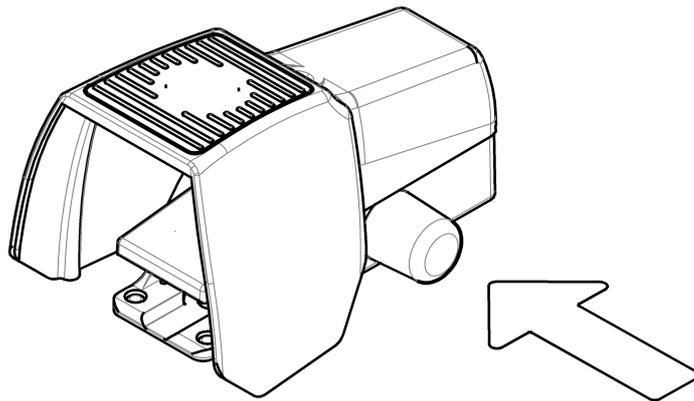

Fig. 4: Releasing the foot-operated switch



Note:

The lasers are switched on and off with the push-buttons (fig. 1, 11 and fig. 2, 20). To extend the service life of the lasers, they switch themselves off independently after 15 minutes. The lasers are switched on again by briefly pressing the foot-operated switch or by pressing the appropriate push-button.

9 Bending busbars

The copper or aluminium busbars are bent with a bending die (fig. 5, 31) that bends the workpiece with both sides over a bending mandrel.

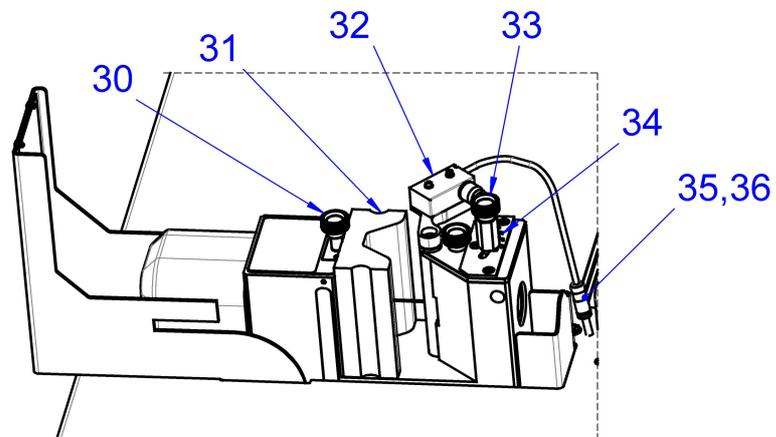

Fig. 5: Bending busbars

Legend

- 30 Locking screw for tools in the load piston
- 31 Bending die
- 32 Electronic angle shutdown switch
- 33 Setting screw for bending bracket
- 34 Angle scale
- 35 Plug
- 36 Socket



Warning!

When bending busbars, swinging parts can be a risk for cutting or crushing parts of the body.

- **Ensure that no persons or objects are present in the work area.**
- **In a dangerous situation, press one of the red emergency stop switches on the unit or alternatively the foot-operated switch beyond the first pressure point to stop the work operation!**

- Press the "Bend" selection push-button.
The machining station is selected once the push-button illuminates green.
- Insert the bending die (fig. 5, 31) in the tool holder of the load piston and tighten the locking screw (fig. 5, 30).
- Insert the electronic angle indicator (fig. 5, 32) in the half-open hole of the main body.
- Insert the plug (fig. 5, 35) of the connection cable in the socket (fig. 5, 36) behind the work block.
- Set the desired bending angle at the setting screw (fig. 5, 33) using the angle scale (fig. 5, 34).
- Hand-tighten the setting screw.



Note:

When bending busbars, a plastic (permanent) and an elastic (spring-back) deformation of the workpiece occurs. To compensate the elastic bending component and a spring-back of the material, the bending angle should always be set 1 – 3° greater than the desired angle.

- Mark the bending line on the workpiece.
Alternatively, the dimension can also be set by the length limit stop equipped with a tape measure (can be extended to 1224 mm).
- Adjust the height of the main body with a rotary knob (fig. 1, 9) and align the bending die centred with the workpiece.

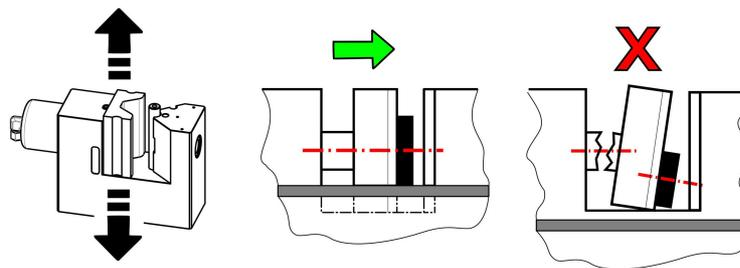

Fig. 6: Alignment of the workpiece



Note:

There is the risk with non-centred bending of the material that the bending die breaks, jams or the unit main body is damaged.

- **Ensure that the material is inserted correctly centred for the bending operation.**

- Place the workpiece between the bending die and the bending mandrel.
The material must lie flat on the table top. The busbar must be positioned so that the centre of the bending corresponds to the laser point or the side edge is aligned at the set limit stop.
- Close the protective hood.

**Note:**

The protective hood is connected with an internal safety switch. The work operation cannot be started when the protective hood is open. The operation can be stopped at any time by lifting the protective hood.

**Warning!**

When bending busbars, there is the risk that small particles are ejected with high speed from the machining area.

■ **Wear your personal protective equipment for all work performed on the unit (see section 2.4 "Personal protective equipment").**

- Start the bending operation by pressing the foot-operated switch to the first pressure point (foot pedal pressed approximately half the distance, corresponds to a force of approx. 20 kg).
The hydraulic pump is activated and feeds oil to the tool.
- Keep the foot-operated switch pressed until the electronic angle shutdown switch ends the bending operation.
The pump is deactivated and the tool travels back to its initial position.

**Note:**

Depending on the material thickness and properties, the angle setting on the unit may need to be adjusted slightly to achieve the desired bending angle of the busbar. Once the angle has been set correctly, it does not need to be readjusted provided the same material is machined.

- To switch off the unit, set the mains switch at (0).

10 Punching holes in the busbars

Holes are punched in the copper or aluminium busbars with a male die (fig. 7, 41) and the appropriate female die (fig. 7, 44). Slot male and female dies have additional pins (fig. 7, 48) or grooves (fig. 7, 49) to simplify an exact angular positioning.

The punched holes can have the following maximum dimensions:

- Round holes: Diameter from 6.6 mm to 21.5 mm
- Slots: 21 mm x 18 mm (width x length)

10 Punching holes in the busbars

EN

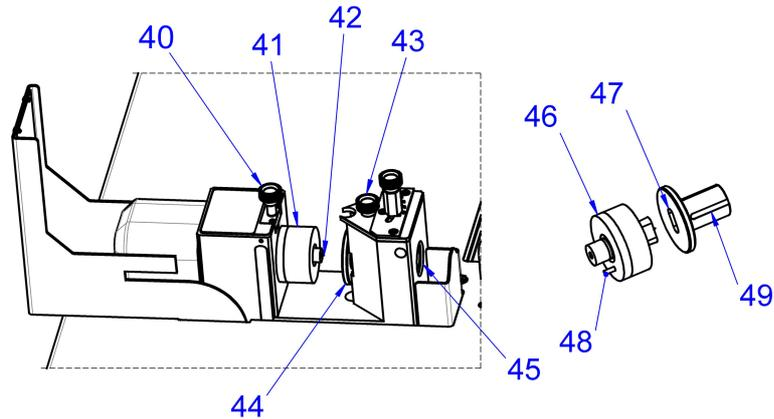

Fig. 7: Punching holes in the busbars

Legend

- 40 Locking screw for tools in the load piston
- 41 Male die with neoprene wiper
- 42 Centring tip of the hole male die
- 43 Locking screw for the hole female die
- 44 Hole female die
- 45 Opening for punch waste
- 46 Male die for slots
- 47 Female die for slots
- 48 Positioning pin
- 49 Position groove for locking screw



Note:

Use only sharp male and female dies. Oil the male die regularly to extend the service life of the tools and to simplify return travel to the initial position.

- Press the "Punch hole" selection push-button.
The machining station is selected once the push-button illuminates green.
- To punch holes, remove the bending die and the electronic angle indicator from the work block.
- Insert the hole female die (fig. 7, 44) in the main body and tighten the locking screw (fig. 7, 43). When a slot female die is used, the corresponding groove (fig. 7, 49) must point upwards.
- Insert the male die (fig. 7, 41) in the tool holder of the load piston and tighten the locking screw (fig. 7, 40). For slot male dies (fig. 7, 46), ensure that the positioning pin (fig. 7, 48) sits correctly in the appropriate hole of the load piston and the slot alignment matches the female die.

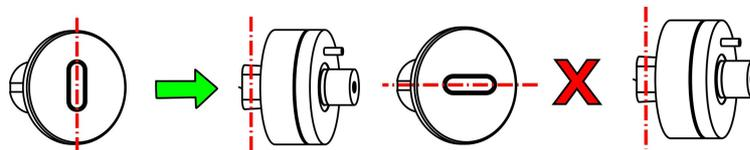

Warning!

If an incorrect tool combination is used, there is the risk that tool parts split off and are ejected from the machining area.

- Ensure that the correct tool combination is deployed.
- Wear your personal protective equipment for all work performed on the unit (see section 2.4 "Personal protective equipment").

- Now mark and scratch the desired hole positions on the busbar.
Alternatively, the dimension can also be set by the length limit stop equipped with a tape measure (can be extended to 1224 mm).
- Adjust the height of the main body with a rotary knob (fig. 1, 9) to the punch centre.

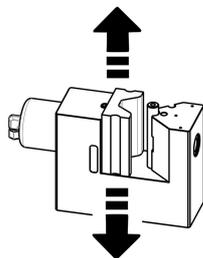

Fig. 8: Setting the punch centre

- Set the centring tip of the male die (fig. 7, 42) directly at the centre mark. This allows the hole pattern to be punched exactly.
- Close the protective hood.



Note:

The protective hood is connected with an internal safety switch. The work operation cannot be started when the protective hood is open. The operation can be stopped at any time by lifting the protective hood.



Warning!

When punching holes, there is the risk that small particles are ejected with high speed from the machining area.

- **Wear your personal protective equipment for all work performed on the unit (see section 2.4 "Personal protective equipment").**

- Start the punching operation by pressing the foot-operated switch to the first pressure point (foot pedal pressed approximately half the distance, corresponds to a force of approx. 20 kg).
The hydraulic pump is activated and feeds oil to the tool.
- Keep the foot-operated switch pressed until the electronic end position switch in the main body deactivates the hydraulic pump and the tool travels back to its initial position.



Note:

The neoprene wiper presses the busbar against the female die until the male die has travelled out of the material and the workpiece can be removed.

- To switch off the unit, set the mains switch at (0).

11 Cutting busbars



Warning!

When cutting busbars, the blade can be a risk for cutting or crushing parts of the body.

- Ensure that nobody intervenes in the cutting area, in particular, after starting a cutting operation.
- In a dangerous situation, press one of the red emergency stop switches on the unit or alternatively the foot-operated switch beyond the first pressure point to stop the work operation!

Busbars are cut with an 8 mm wide blade that presses an 8 mm wide strip out of the busbar and so divides the workpiece dimension-conform.

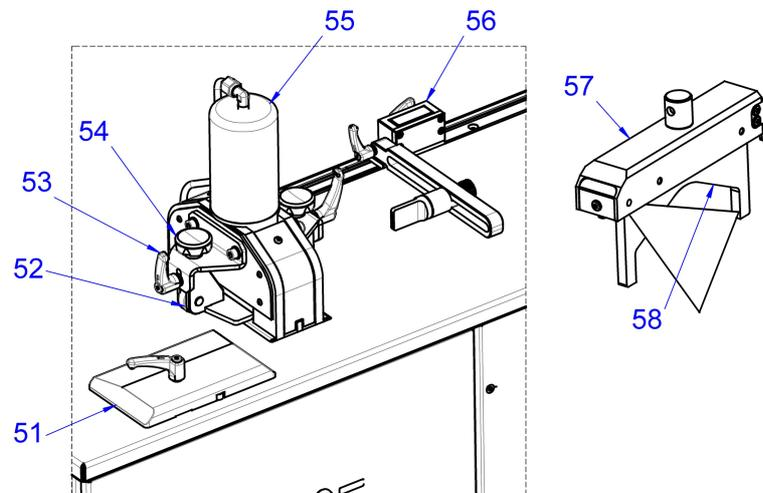

Fig. 9: Cutting busbars

Legend

- 51 Side guide plate
- 52 Retainer with ball bearing
- 53 Locking lever for retainer
- 54 Clamping screw for retainer
- 55 High-pressure hydraulic cylinder
- 56 Limit stop with tape measure
- 57 Cutter bar with integrated line laser
- 58 Blade

- Press the "Cut" selection push-button.
The machining station is selected once the push-button illuminates green.
- Release the clamping lever on the side guide plate (fig. 9, 51) and adjust the guide plate to the width of the busbar.
- Ensure that the workpiece is fed centred in the cutting unit.
- Mark the desired workpiece length centred on the busbar.
- Now introduce the busbar from the side of the support roller (fig. 1, 5) starting in the cutting unit.
- Release the clamping screws (fig. 9, 54) and locking lever (fig. 9, 53) of the two retainers, and adjust the retainer to the material thickness of the workpiece.
The correct setting of the guide plates and retainers ensures a better cutting result.
- Now push the busbar through the cutting unit until the length marking is located exactly below the red laser line.
The workpiece with the correct length results on the side of the limit stop.

- Alternatively, the dimension can also be set by the length limit stop equipped with a tape measure (can be extended to 1224 mm). Move the busbar slowly to the limit stop.
- Press the foot-operated switch to the first pressure point (foot pedal pressed approximately half the distance, corresponds to a force of approx. 20 kg) to start the cutting operation.
The hydraulic pump is activated and feeds oil to the tool.
- After completed cutting operation, release the pressure from the foot-operated switch to deactivate the pump.
The hydraulic oil now flows from the cutting unit back to the oil tank of the pump. The blade travels back to its initial position.
- To switch off the unit, set the mains switch at (0).

12 Replacing the cutting blade



Caution!

When replacing the cutting blade, there is the risk of injury caused by sharp edges.

- Ensure that the blade replacement is performed by appropriately authorised persons.
- Wear your personal protective equipment when replacing the cutting blade (see section 2.4 "Personal protective equipment").

- Open the rear enclosure door (fig.2, 21).

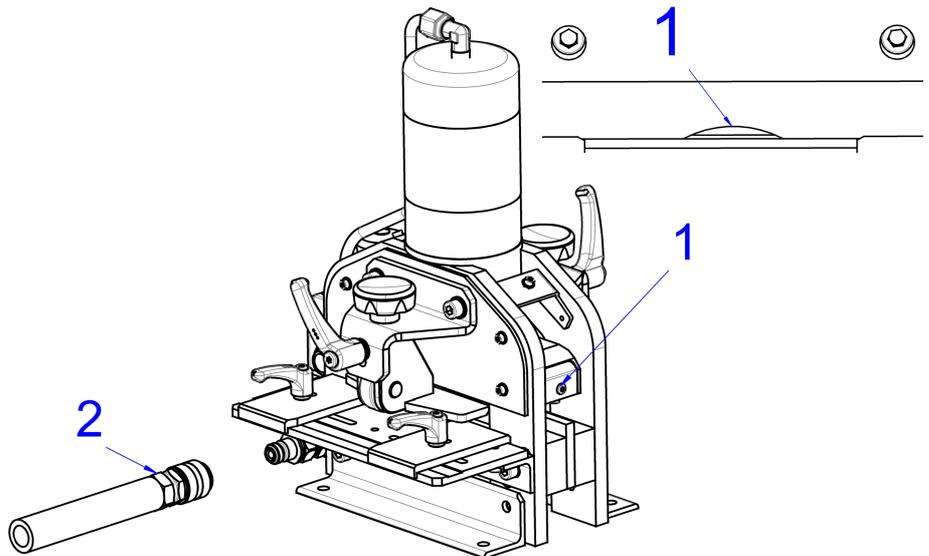

Fig. 10: Blade in the lower position

- Activate the hydraulic pump and allow the blade to travel down until only a small curvature (fig. 10, 1) can be seen between the blade and the counter cutter.
- Switch off the hydraulic pump and immediately disconnect the hydraulic coupling (fig. 10, 2) at the cutting unit so the cutter bar remains at the bottom position.

12 Replacing the cutting blade

EN

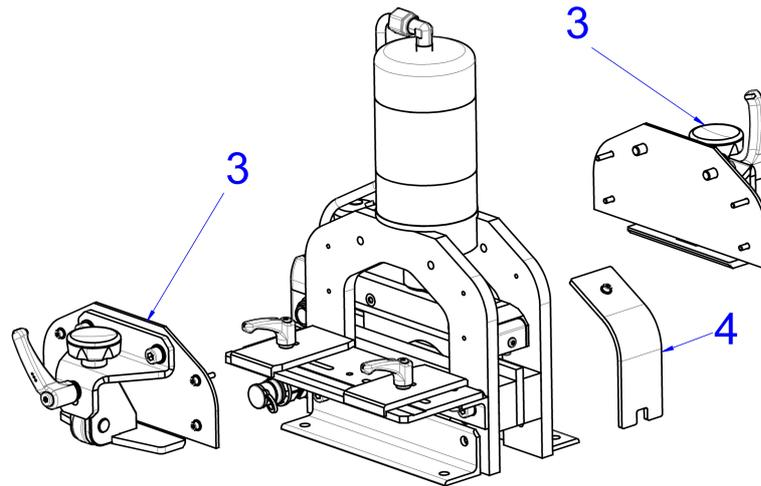

Fig. 11: Dismantling the retainers

- Dismantle the two retainers (fig. 11, 3) and the side protective inspection window (fig. 11, 4).

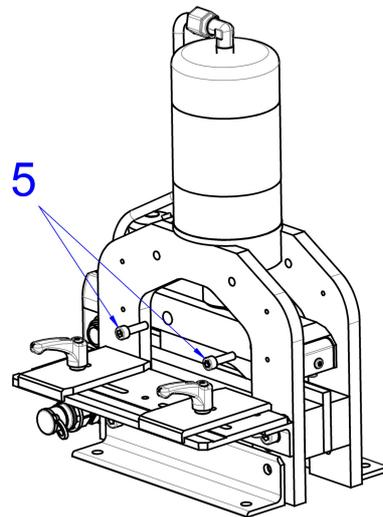

Fig. 12: Loosen the fastening screws

- Now loosen the two M8 screws (fig. 12, 5) on the side of the cutter bar.
- Before removing the screws, secure the blade so it cannot fall down.

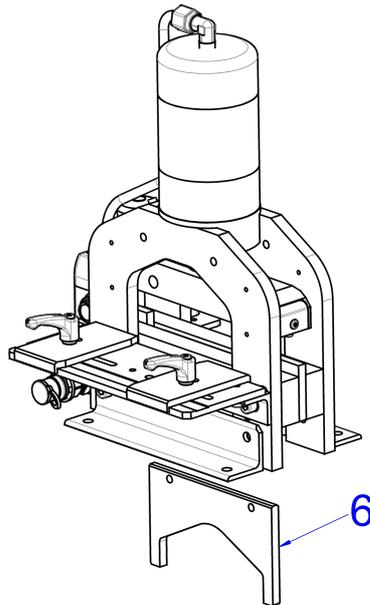

Fig. 13: Removing the blade

- Finally, remove the blade at the bottom of the cutting unit (fig. 13, 6). Take care, the blade is sharp.

Installing the new blade:

- Insert the new blade from below and push upwards to the cutter bar.
- Screw in the two M8 screws (fig. 12, 5) from the side with 15 – 20 Nm torque.
- Finally, screw on the retainers (fig. 11, 3) and the protective inspection window (fig. 11, 4), and reconnect the hydraulic hose.

13 Maintenance and inspection

The user is obliged to maintain and service the "Busbar machining, mobile" in accordance with the details in the operating instructions, and in accordance with country-specific standards and rules.

The maintenance intervals are classified in accordance with the recommended frequency.



Caution!

When a unit has been switched on, there is the risk of it starting, such as for inadvertent actuation of the foot-operated switch with the associated risk of injury in the area of unit components.

- **Before any servicing and repair work, ensure that the unit mains plug has been removed to prevent inadvertent starting.**

Before every use...

- ... Visually inspect the unit and the foot-operated switch for damage.
- ... Check all electrical and hydraulic connection lines for damage.
- ... Check the correct, secure attachment of the hydraulic couplings.
- ... Check the correct functioning of the foot-operated switch.

Once after 50 operating hours...

- ... Perform a complete oil change with 3 litres HLP 46 hydraulic oil.

Weekly...

- ... Clean the complete unit. To prevent damage to the safety instructions on the unit, do not use any aggressive cleaning agents.
- ... Clean the blade and the counter cutters by blasting with dry compressed air.
- ... Grease lightly the blade and the counter cutters externally with universal grease.
- ... Oil lightly the male and female dies.



Note:

An inadequate protective film or an excessively long downtime of the unit can lead to corrosion and so impair the function of the components.

- ... Check the correct functioning of the safety shutdown on the protective hood and the foot-operated switch.
- ... Check the correct functioning of the emergency stop switches of the unit when the pump is activated.



Warning!

There is risk of injury for defective safety equipment.

- **If the inspection of the safety shutdown equipment determined that they do not stop the unit, bring the unit to standstill immediately.**
- **Repair the safety shutdown equipment without delay.**
- **Operate the unit again only after the repair work has been completed.**

Monthly...

- ... Visually inspect tools and the main body for defects or breakouts, and replace if necessary.
- ... Visually inspect the blade and counter cutters for defects or breakouts, and replace if necessary.
- ... Check the markings and warning signs on the unit for readability and damage, and replace if necessary (see section 2.2 "Symbols on the unit").
- ... Check the oil level, and add HLP 46 hydraulic oil to the "Max" marking if necessary.

Yearly...

- ... Perform a complete oil change with 3 litres HLP 46 hydraulic oil.

Every 6 years...

- ... Replace the hydraulic hose.

Maintenance, inspections and repairs must be performed by qualified electricians in accordance with the regulations valid in the associated country.

14 Dismantling and disposal



Caution!

There is a risk of injury when lifting the unit in its packaging or if the lifted unit falls (total weight approx. 390 kg).

- **Please note the maximum weights that may be lifted by persons. It may be necessary to use lifting gear.**
- **Do not stand below the lifted unit.**

- Wear your personal protective equipment, in particular gloves and safety work shoes, also for the dismantling and disposal of the unit (see section 2.4 "Personal protective equipment").

The "Busbar machining, mobile" must be disposed of or recycled appropriately in accordance with the country-specific regulations.

15 Contacts

Your contacts for sales and service

Sales

- ras-info@rittal.com
- +49 2772 505 3223

RAS series products service

- service@rittal.com
- +49 2772 505 1855

Rittal – The System.

Faster – better – everywhere.

- Enclosures
- Power Distribution
- Climate Control
- IT Infrastructure
- Software & Services

You can find the contact details of all Rittal companies throughout the world here.



www.rittal.com/contact

RITTAL GmbH & Co. KG
Postfach 1662 · D-35726 Herborn
Phone +49(0)2772 505-0 · Fax +49(0)2772 505-2319
E-mail: info@rittal.de · www.rittal.com

08.2018 / D-0100-00000009 Rev. 00

ENCLOSURES

POWER DISTRIBUTION

CLIMATE CONTROL

IT INFRASTRUCTURE

SOFTWARE & SERVICES

FRIEDHELM LOH GROUP

