



## AMP S

- AMP S (BAS) CH TEC
- AMP S (BAS) PC TEC
- AMP S (BAS) PM TEC

## AMP L

- AMP L (BAS) CH TEC
- AMP L (BAS) PC TEC
- AMP L (BAS) PM TEC

## AMP L LT

- AMP L LT CH TEC
- AMP L LT PC TEC
- AMP L LT PM TEC

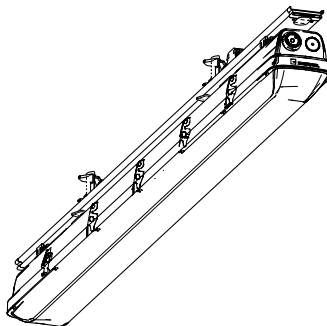

### EN Mounting instructions

Important notices. Please, read first! Keep the instructions safe! Specifications are subject to change without notice! If you have questions, please contact the manufacturer.

### DE Montageanleitung

Wichtige Hinweise. Bitte zuerst lesen! Anleitung aufbewahren! Technische Änderungen vorbehalten! Bei Fragen wenden sie sich an den Hersteller.

### FR Notice de montage

Remarques importantes. À lire en premier lieu! Conservez cette notice! Modifications techniques sans préavis! Si vous avez des questions, veuillez contacter le fabricant.

### IT Istruzioni di montaggio

Nota importanti. Si prega di leggere prima! Conservare le istruzioni! Modifiche tecniche senza preavviso! Per chiarimenti rivolgersi al produttore.

### ES Instrucciones de montaje

Notas importantes. Por favor, lea primero! ¡Guarde las instrucciones! ¡Reservado el derecho de realizar modificaciones técnicas sin preaviso! Si tiene alguna pregunta, póngase en contacto con el fabricante.

### NL Montagehandleiding

Belangrijke informatie. Gelieve eerst te lezen! Houd deze gebruiksaanwijzingen zorgvuldig bij! Technische wijzigingen blijven voorbehouden! Als u vragen hebt, kan u contact opnemen met de fabrikant.

### SV Installationsanvisning

Viktigt information. Läs först! Spara anvisningen! Med reservation för tekniska ändringar! Om du har frågor ber vi dig ta kontakt med tillverkaren.

### FI Asennusohje

Tärkeä huomautus. Lue ensin! Säilytä käyttöopas! Oikeudet teknisiin muutoksiin pidätetään! Lähetä mahdolliset kysymykset valmistajalle.

### RU Инструкция по монтажу

Важная информация. Просьба ознакомиться перед началом работ! Сохраняйте инструкцию! Компания сохраняет за собой право на внесение технических изменений! При возникновении вопросов обращайтесь к производителю.

### PL Instrukcja montażu

Ważne wskazówki/ uwagi. Proszę pierwsze przeczytać całość instrukcji. Proszę zachować instrukcję! Zastrzega się prawo do wprowadzania zmian technicznych. W razie pytań skontaktuj się z producentem.

### ZH 安装说明

重要提示。请先阅读! 保留本说明! 请勿执行技术变动! 如有问题, 请咨询制造商。

### AR

تعليمات التركيب  
ملاحظات هامة. يرجى القراءة أولاً!  
إبقاء التعليمات!  
تخضع المواصفات للتغيير دون تقديم إشعار!  
إذا كان لديك أسئلة، الرجاء الاتصال بالشركة المصنعة.

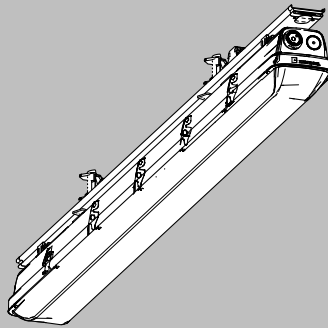

**i** **OPTIONS**



[www.zumtobel.com/amphibia](http://www.zumtobel.com/amphibia)



E3, E3D, E3D-UK: Emergency options (pages 3-5)

**i**

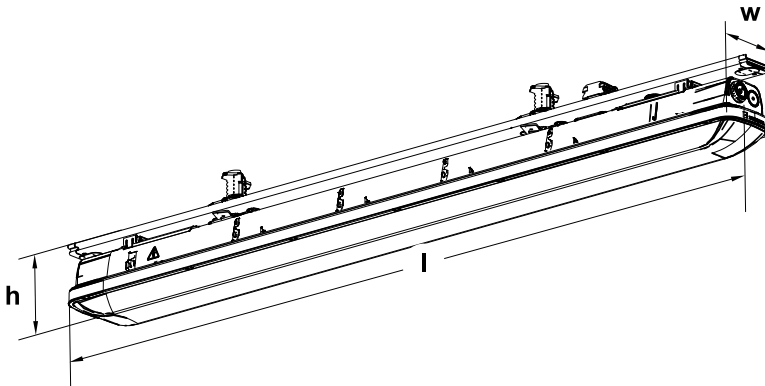

	l	w	h	m	OPTIONS
AMP S TEC	1111 mm	91,5 mm	110 mm	2,3 - 3,0 kg	www.*
AMP L TEC	1611 mm	91,5 mm	110 mm	2,1 - 3,9 kg	www.*

**i**

**IP20**  
TECTON

**IP66**  
AMPHIBIA

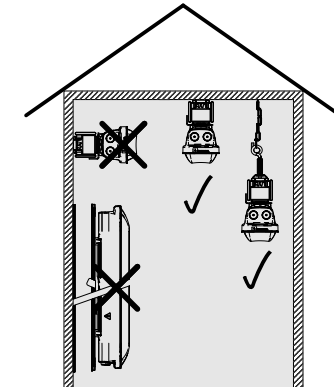
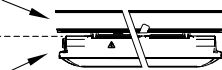

**1** OPTION EMERGENCY ONLY: E3, E3D, E3D-UK

**1a**

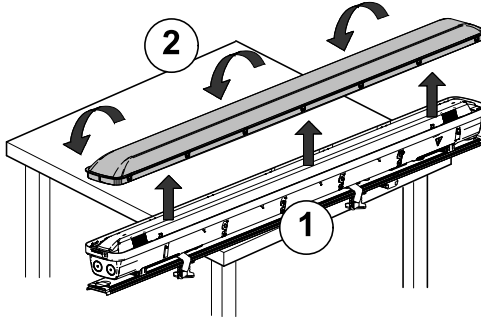

**1b**

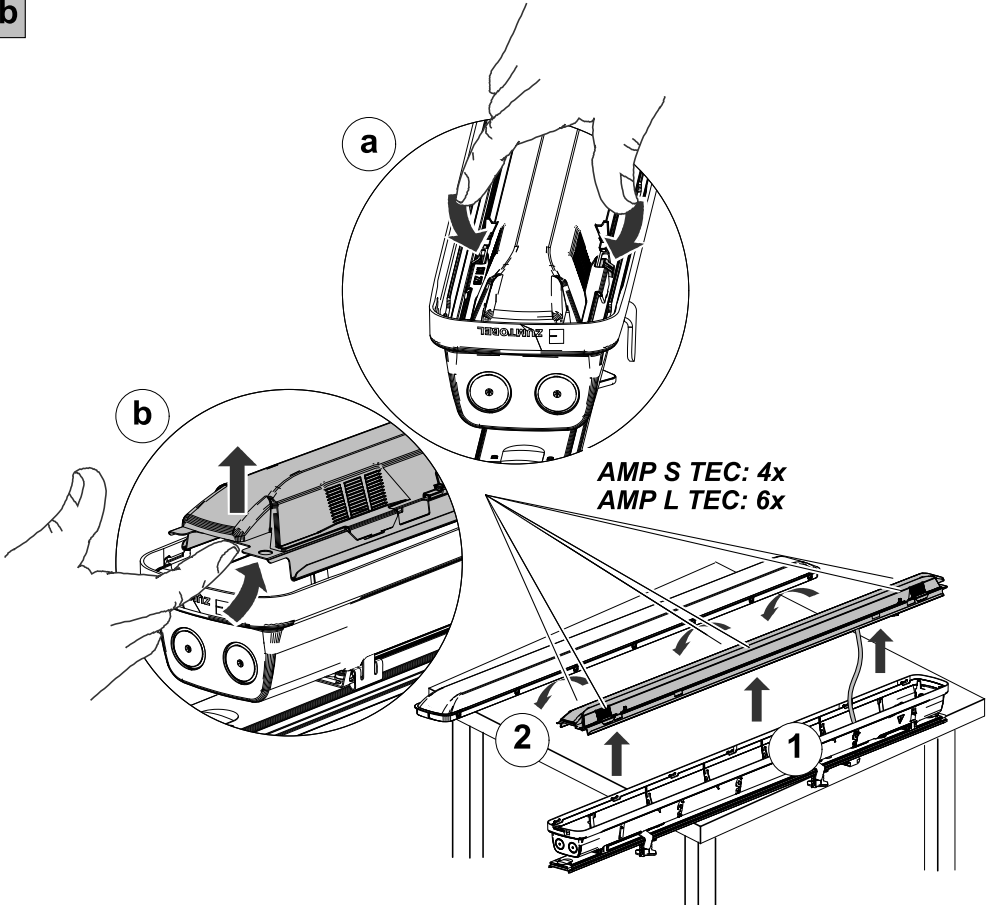

**i** E3, E3D, E3D-UK

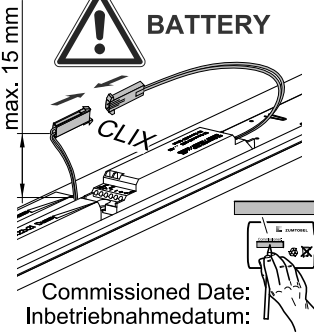

**i** ECD, ECP, ECC

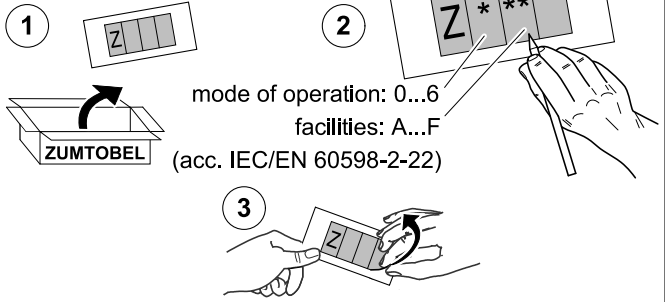

**1c**

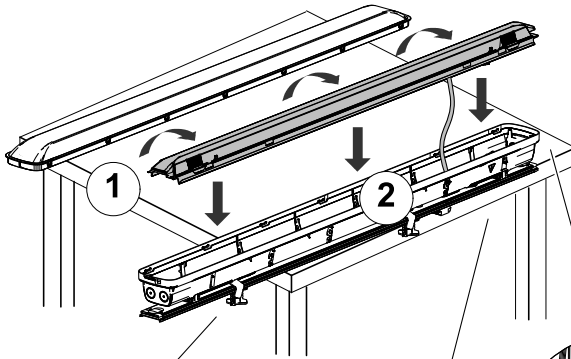

**AMP S TEC: 4x**  
**AMP L TEC: 6x**

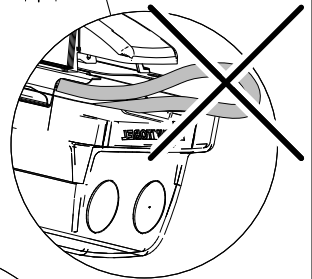
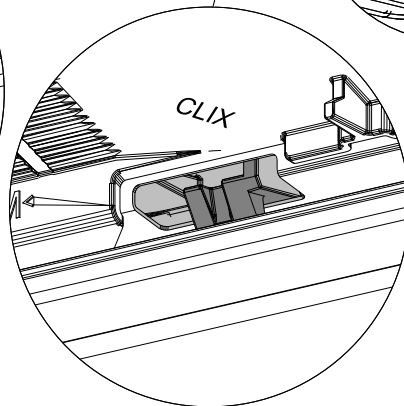
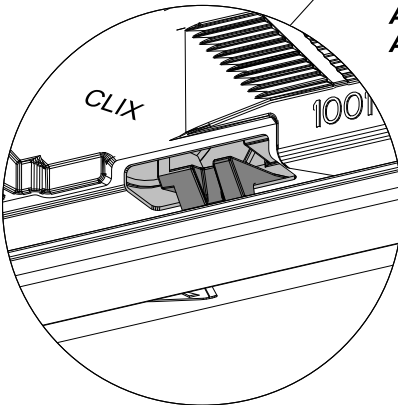

1d

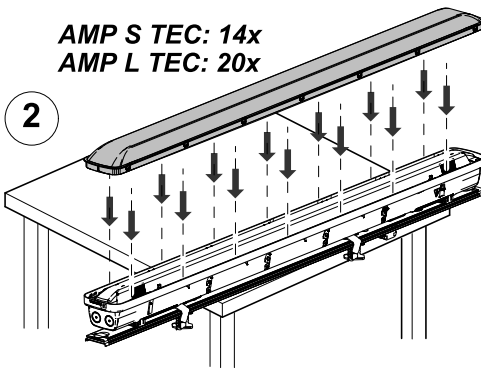
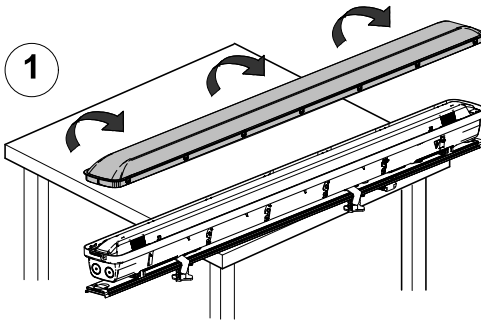

AMP S TEC: 14x  
AMP L TEC: 20x



IP66

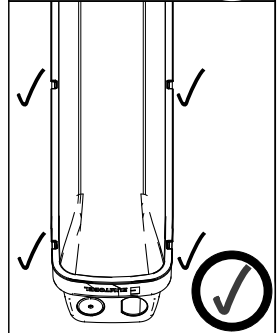
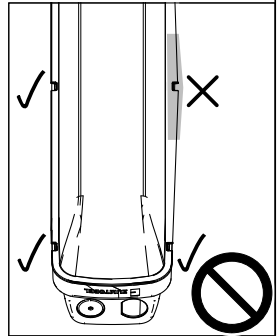

2

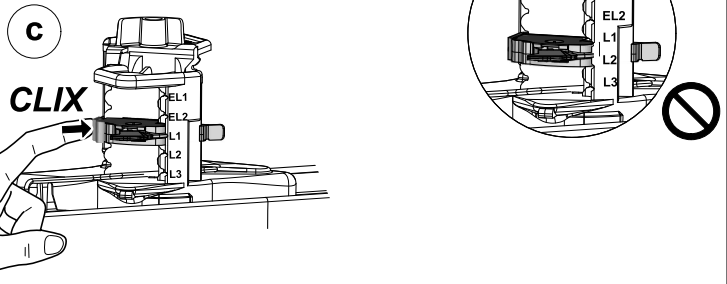
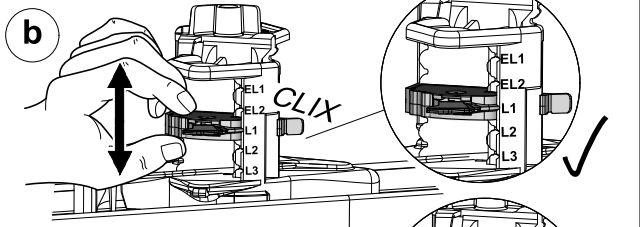
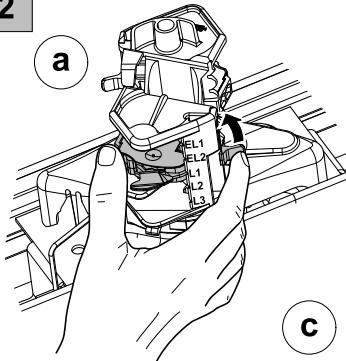

3

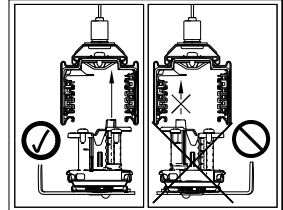
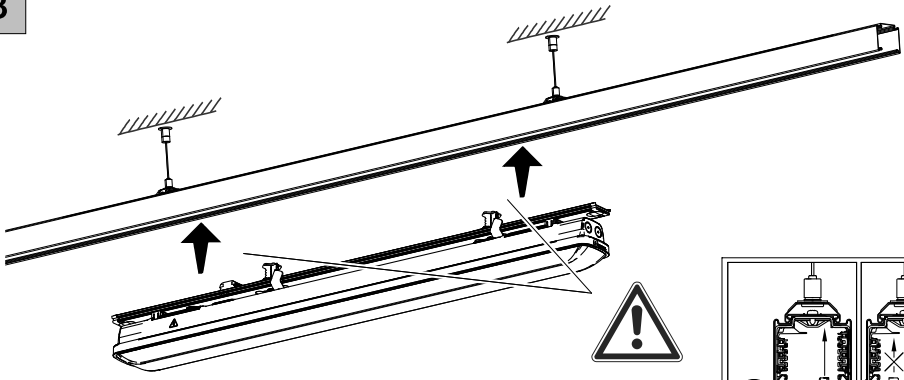

4

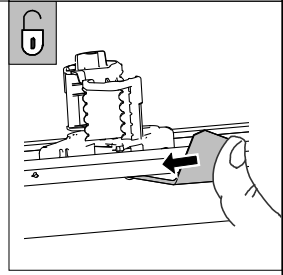
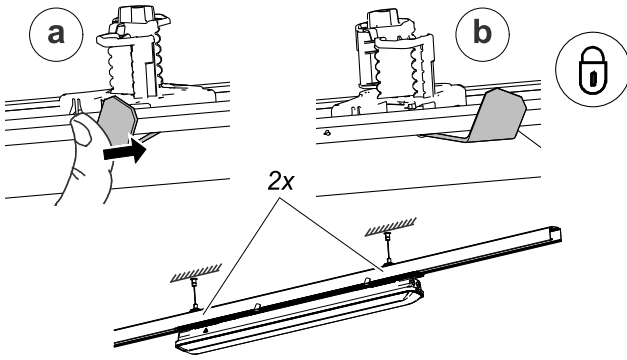

### i DISMOUNTING

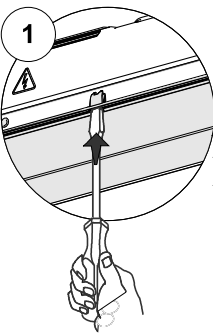

AMP S TEC: 14x  
AMP L TEC: 20x

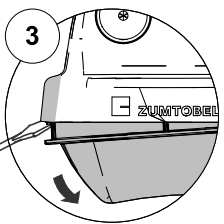
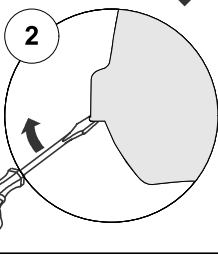
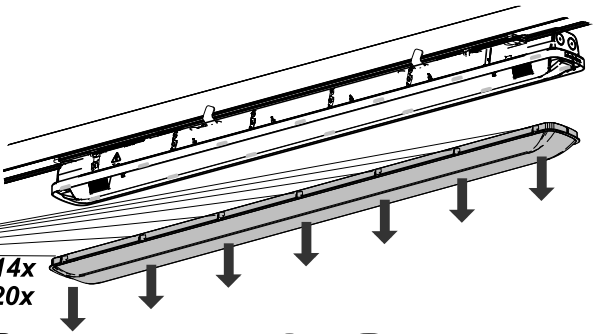

## **DE** Materialhinweis!

Chemische Einflüsse, sei es durch direkten Kontakt oder durch in der Atmosphäre schwebende Stoffe und ungeeignete Reinigungsmethoden können zu einer Beschädigung der Leuchte führen!  
Amphibia Leuchten sind in 3 verschiedenen Materialvarianten erhältlich: Polycarbonat, PMMA oder Chemo. Diese Kunststoffe weisen eine unterschiedliche Beständigkeit gegen chemische Substanzen auf. Stellen Sie sicher, dass Sie das richtige Material verwenden, das gegen schädliche Substanzen in luftgetragenen Substanzen oder in Reinigungsmitteln resistent ist (abhängig von der Anwendung). Wenn Sie Fragen haben, wenden Sie sich an den Hersteller.

## **EN** Luminaire materials!

Aggressive chemicals, in direct contact with the luminaire or in the form of airborne substances can damage the fitting. So can unsuitable cleaning agents.  
Amphibia luminaires are available in 3 different material versions: polycarbonate, PMMA or Chemo. These plastics have a different resistance to chemical substances.  
Make sure you use the proper material, resistant to potential damaging substances present in airborne substances or in cleaning agents (depending on the application).  
If you have questions, contact the manufacturer.

## **FR** Notice importante!

Les agents chimiques, en contact direct avec le luminaire ou sous forme de particules en suspension dans l'air, de même que les méthodes de nettoyage inadéquates peuvent entraîner une détérioration du luminaire !  
Les luminaires Amphibia sont disponibles en 3 matériaux différents : polycarbonate, PMMA ou Chemo. Ces plastiques ont une résistance différente aux substances chimiques.  
Assurez-vous d'utiliser le matériau approprié, résistant aux substances potentiellement dommageables transportées dans l'air ou présentes dans les agents de nettoyage (en fonction de l'application).  
Si vous avez des questions, contactez le fabricant.

## **IT** Nota sul materiale!

Gli agenti chimici, a contatto diretto oppure in sostanze sospese nell'atmosfera, possono danneggiare gli apparecchi di illuminazione. Ugualmente dannoso può risultare un inadeguato utilizzo di prodotti per la pulizia quali concentrati alcalinici, soluzioni acide o altri solventi.  
Gli apparecchi Amphibia sono disponibili in tre diversi materiali: polycarbonato, PMMA o CHEMO.  
Queste materie plastiche hanno una diversa resistenza alle sostanze chimiche.  
Assicuratevi di utilizzare il materiale più appropriato, resistente a potenziali sostanze dannose disperse nell'aria o contenute in detersivi (a seconda dell'applicazione).  
In caso di domande, contattare il produttore.

## **NL** Materiaal Aanwijzingen!

Chemische invloeden, hetzij door direct contact, hetzij door stoffen die in de atmosfeer rondzweven of niet geschikte reinigingsmethodes, kunnen het armatuur schade toedienen.  
Amphibia-armaturen zijn verkrijgbaar in 3 verschillende materiaalversies: polycarbonaat, PMMA of Chemo. Deze kunststoffen hebben een verschillende weerstand tegen chemische stoffen.  
Zorg ervoor dat u het juiste materiaal gebruikt dat bestand is tegen potentieel schadelijke stoffen in de lucht of in reinigingsmiddelen (afhankelijk van de toepassing).  
Bij vragen kunt u altijd met de fabrikant contact opnemen.



\*[www.zumtobel.com/amphibia](http://www.zumtobel.com/amphibia)



## **DE** Hinweise für die Montage und den Betrieb!

Die Montage und Inbetriebnahme der Leuchte sowie jede Veränderung an der Leuchte darf nur von autorisierten Fachkräften (qualifizierter Elektriker) durchgeführt werden. Die nationalen Errichterbestimmungen sind zu beachten. Vor jeder Arbeit an der Leuchte ist diese vom Netz zu trennen. **Hot Plug-in ist nicht möglich und kann zu Schäden an der Leuchte führen!**

Der Hersteller haftet nicht für Schäden, die aus fehlerhafter Montage, aus unsachgemäßem Betrieb oder unautorisierten Veränderungen an der Leuchte resultieren.



Die Lichtquelle dieser Leuchte darf nur vom Hersteller oder einem von ihm beauftragten Servicetechniker oder einer vergleichbar qualifizierten Person ausgetauscht werden.

**Vorsicht, Gefahr eines elektrischen Schlags.**

Technische Änderungen vorbehalten! Bei Fragen wenden sie sich an den Hersteller.

## **EN** Instructions for installation and operation!

The installation and commissioning of the luminaire as well as any modification to the luminaire may only be performed by authorized personnel (qualified electrician). National installation regulations must be observed. Before any work on the appliance is done, it must be disconnected from mains.

**Hot plug-in is not an option and may cause damage to the lamp or luminaire!**

The manufacturer is not liable for damages resulting from improper or faulty installation or operation or from unauthorized modifications to the luminaire.



The light source contained in this luminaire shall only be replaced by the manufacturer or his service agent or a similarly qualified person.

**Caution, risk of electric shock!**

Specifications are subject to change without notice! If you have questions, please contact the manufacturer.

## **FR** Instructions pour l'installation et l'utilisation!

L'installation et la mise en service du luminaire ainsi que toute modification au luminaire doivent être effectuées par un personnel autorisé (électricien qualifié). Les règles nationales d'installation doivent être respectées. Avant toute intervention sur l'appareil, il doit être débranché de son alimentation.

**Le branchement à chaud est interdit, et peut endommager à la lampe ou le luminaire!**

Le fabricant décline toute responsabilité pour les dommages résultant d'une mauvaise installation ou opération, ou d'une modification non autorisée du luminaire.



La source lumineuse présente dans le luminaire ne peut être remplacée que par le fabricant, par son service technique ou une personne qualifiée.

**Avertissement, risque de choc électrique.**

Sous réserve de modifications des spécifications techniques! Pour toute question, contactez le fabricant.

## **IT** Istruzioni per l'installazione e il funzionamento!

L'installazione e la messa in servizio degli apparecchi, nonché qualsiasi modifica dell'apparecchio può essere eseguita solo da personale autorizzato (elettricista qualificato). Le norme nazionali di installazione devono essere rispettate. Prima di qualsiasi intervento sull'apparecchio, questo deve essere scollegato dalla rete.

**Non è possibile un Hot Plug In e può causare danni alla lampada o all'apparecchio!**

Il produttore non si assume alcuna responsabilità per i danni derivanti da un'installazione impropria o difettosa o per modifiche non autorizzate apportate all'apparecchio.



La sorgente luminosa contenuta in questo apparecchio può essere sostituita solo dal produttore o da un centro assistenza autorizzato o da una persona qualificata.

**Attenzione, rischio di folgorazione!** Modifiche tecniche sono soggette a cambiamenti senza preavviso! Se avete domande, si prega di contattare il produttore.

## **NL** Aanzwijzingen voor installatie en bediening!

De installatie en inbedrijfstelling van het armatuur, alsook elke wijziging in of aan het armatuur mogen alleen door bevoegd personeel (elektricien) worden uitgevoerd. De nationale installatie voorschriften moeten worden nageleefd. Voor alle werkzaamheden aan het apparaat, moet deze worden losgekoppeld van het net.

**Hot plug-in is niet mogelijk en kan schade aan de lichtbron of het verlichtingstoestel veroorzaken!**

De fabrikant is niet aansprakelijk voor schade als gevolg van onjuiste of foutieve installatie, bediening of schade welke het gevolg zijn van niet geautoriseerde wijzigingen aan het armatuur.



De lichtbron in dit armatuur mag enkel door de fabrikant, een service agent of een gelijkwaardig gekwalificeerd persoon vervangen worden.

**WAARSCHUWING: Gevaar voor elektrische schokken.**

Technische wijzigingen vorbehalten! Als u vragen hebt, kunt u contact opnemen met de fabrikant.