

## phase sequence indicator - Test plug, for reefer containers



Product description	
BALS-Prd.-Nr	2298
EAN	4024941022989
Product category	Phase sequence indicator
Current	32A
Number of poles	4p
Arrangement of phases	3P+PE
Position of earth contact	3 h
Voltage	380V~(50Hz) 440V~(60Hz)

Product description	
Frequency	50/60Hz
Protection degree	IP44
Display of the three phases	TRUE
Motor rotation direction test.	TRUE
No-contact detection of direc.	TRUE
Height	142mm
Width	66mm
Depth	66mm

Logistics data	
Weight/pcs	0.225 kg / Piece
Packaging	Carton
Content amount	1 ST
EAN	4024941022989
Length	205 mm
Width	102 mm
Height	134 mm
Weight	0.285 kg
Volume	2,118.48 ccm

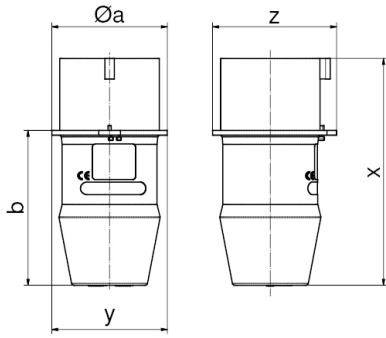

Ampere Polzahl	16 4	16 5	32 4	32 5
Ø a	58,0	64,0	66,0	73,0
b	76,0	80,0	95,0	98,0
x	112,0	116,0	141,0	144,0
y	58,0	64,0	66,0	73,0
z	63,0	68,0	78,0	79,0