

## Panel mounting appliance inlet - flange 75x75 with closure cap



Product description	
BALS-Prd.-Nr	754
EAN	4024941007542
Product category	domestic-type panel mounting appliance inlet, straight
Current	16A
Number of poles	3p
Arrangement of phases	2P+PE
Voltage	250V~
Frequency	AC

Product description	
Protection degree	IP67
Colour code	blue RAL 5015
Colour of appliance	Closure cap grey RAL 7035, Collar black RAL 9005, Enclosure blue RAL 5015
Connection design	with screw terminal
Maximum conductor size	4,0 qmm
Cable entry	other
Height	75mm
Width	75mm
Depth	91mm
Flange size vertical in mm	75mm
Flange size horizontal in mm	75mm
Drill hole dist. vertical mm	60mm
Drill hole dist. horizontal mm	60mm
Material of enclosure	plastic
Contacts	the contact carrier is made of high temperature resistant material, the contacts are brass nickel plated

Additional technical properties	
	also suitable for Belgian/French standard
	With hammer symbol
	With closure cap

Logistics data	
Weight/pcs	0.166 kg / Piece
Packaging	Bag
Content amount	1 ST
EAN	4024941007542
Length	91 mm
Width	75 mm
Height	75 mm
Weight	0.167 kg
Volume	511.875 ccm
Packaging	Carton
Content amount	10 ST
EAN	4024941835794
Length	245 mm
Width	177 mm
Height	185 mm
Weight	1.793 kg
Volume	7,140 ccm

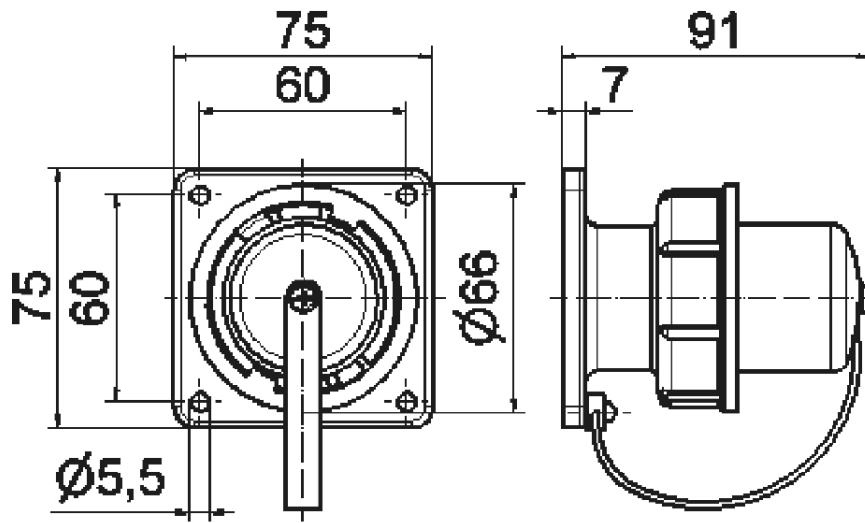

18 MB 16