

panel mounting appliance inlet - without hinged cover



Product description	
BALS-Prd.-Nr	2611
EAN	4024941026116
Product category	Surface mounting appliance inlet
Current	16A
Number of poles	5p
Arrangement of phases	3p+N+PE
Position of earth contact	9 h
Voltage	120/208 - 144/250V~
Frequency	50/60Hz

Product description	
Protection degree	IP44
Colour code	blue RAL 5015
Colour of appliance	Collar blue RAL 5015, Enclosure grey RAL 7035
Connection design	with screw terminal
Maximum conductor size	2,5 qmm
Cable entry	other
Height	129mm
Width	84mm
Depth	78mm
Flange size vertical in mm	84mm
Flange size horizontal in mm	84mm
Drill hole dist. vertical mm	64mm
Drill hole dist. horizontal mm	64mm
Material of enclosure	Polyamide
Contacts	The contacts are brass, The contact carrier is made of polyamide

Logistics data	
Weight/pcs	0.18 kg / Piece
Packaging	Bag
Content amount	1 ST
EAN	4024941026116

Logistics data	
Length	78 mm
Width	84 mm
Height	129 mm
Weight	0.181 kg
Volume	845.208 ccm
Packaging	Carton
Content amount	10 ST
EAN	4024941818841
Length	258 mm
Width	183 mm
Height	212 mm
Weight	1.952 kg
Volume	8,750 ccm

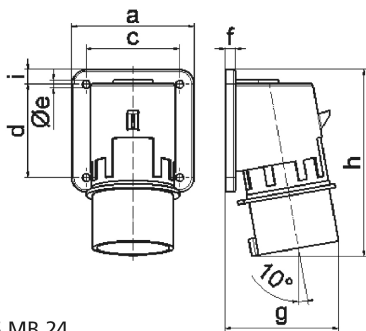

5 MB 24

Ampere	16	16	16	32	32	32
Polzahl	3	4	5	3	4	5
a	74,0	75,0	84,0	90,0	90,0	90,0
b	84,0	100,0	84,0	75,0	75,0	75,0
c	58,0	62,0	64,0	78,0	78,0	78,0
d	64,0	74,0	64,0	45,0	45,0	45,0
e ø	5,5	4,3	5,5	5,5	5,5	5,5
f	12,0	12,0	7,0	7,0	7,0	7,0
g	70,0	77,0	78,0	86,0	86,0	88,0
h	128,0	145,0	129,0	138,0	138,0	140,0
i	-	-	-	13,0	13,0	13,0
Leiter mm ² min	1	1	1	2,5	2,5	2,5
Leiter mm ² max	2,5	2,5	2,5	6	6	6