

# flanged appliance inlet - flange 120x120, fixing centers 100x100

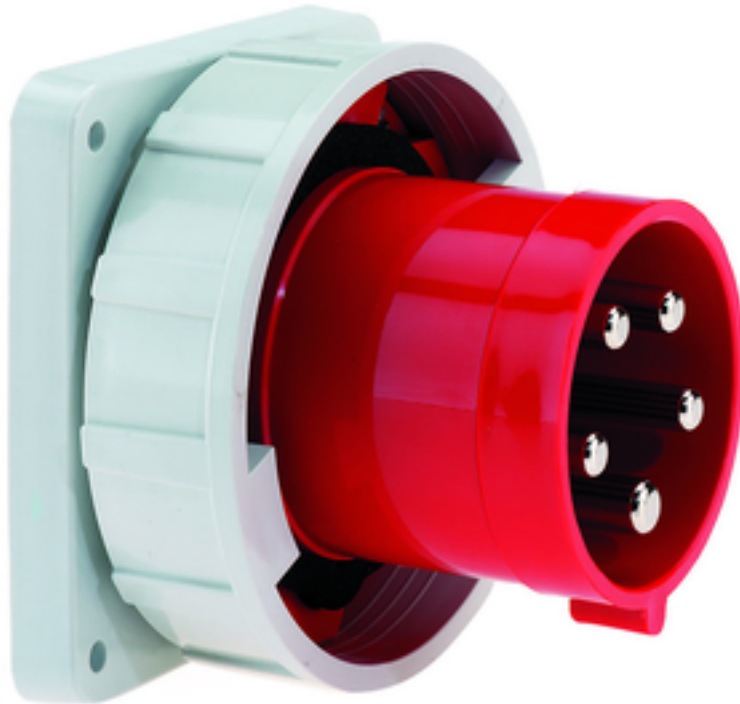

Product description	
BALS-Prd.-Nr	2876
EAN	4024941028769
Product category	TE flanged appliance inlet straight
Current	125A
Number of poles	5p
Arrangement of phases	3p+N+PE
Position of earth contact	6 h
Voltage	200/346 - 240/415V~

Product description	
Frequency	50/60Hz
Protection degree	IP67
Colour code	red RAL 3000
Colour of appliance	Collar red RAL 3000, Enclosure grey RAL 7035, Bayonet ring grey RAL 7035
Connection design	screw terminal as box terminal
Maximum conductor size	50.0 qmm
Cable entry	other
Height	125mm
Width	125mm
Depth	143.5mm
Flange size vertical in mm	120mm
Flange size horizontal in mm	120mm
Drill hole dist. vertical mm	100mm
Drill hole dist. horizontal mm	100mm
Material of enclosure	Polyamide
Contacts	The contact carrier is made of high temperature resistant material, the contacts are brass nickel plated

Additional technical properties	
	Collar in middle of flange

Logistics data	
Weight/pcs	1.11 kg / Piece
Packaging	Bag
Content amount	1 ST
EAN	4024941028769
Length	143.5 mm
Width	125 mm
Height	125 mm
Weight	1.111 kg
Volume	2,242.188 ccm
Packaging	Carton
Content amount	5 ST
EAN	4024941946308
Length	330 mm
Width	216 mm
Height	260 mm
Weight	5.776 kg
Volume	17,062.5 ccm

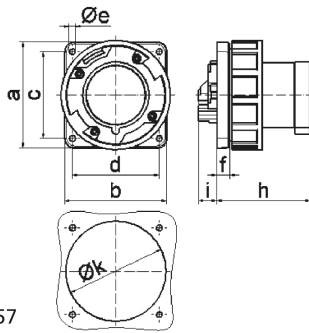

5 MB 57

Ampere	125	125	125			
Polzahl	3	4	5			
a	120,0	120,0	120,0			
b	120,0	120,0	120,0			
c	100,0	100,0	100,0			
d	100,0	100,0	100,0			
e ø	6,5	6,5	6,5			
f	13,0	13,0	13,0			
h	116,0	116,0	116,0			
i	20,0	20,0	20,0			
k	104,0	104,0	104,0			
Leiter mm² min	16	16	16			
Leiter mm² max	50	50	50			