

## panel mounting appliance inlet - with hinged cover



Product description	
BALS-Prd.-Nr	26053
EAN	4024941260534
Product category	TE surface mounting appliance inlet Quick-Connect
Current	32A
Number of poles	5p
Arrangement of phases	3p+N+PE
Position of earth contact	6 h
Voltage	200/346 - 240/415V~
Frequency	50/60Hz

Product description	
Protection degree	IP44
Colour code	red RAL 3000
Colour of appliance	Hinged lid grey RAL 7035, Enclosure grey RAL 7035, Collar red RAL 3000
Connection design	screwless spring-clamp technology
Maximum conductor size	6,0 qmm
Cable entry	other
Height	148mm
Width	90mm
Depth	116mm
Flange size vertical in mm	75mm
Flange size horizontal in mm	90mm
Drill hole dist. vertical mm	45mm
Drill hole dist. horizontal mm	78mm
Material of enclosure	Polyamide
Contacts	The contact carrier is made of high temperature resistant material, the contacts are brass nickel plated

Additional technical properties	
	With hinged lid

Logistics data	
Weight/pcs	0.337 kg / Piece

Logistics data	
Packaging	Bag
Content amount	1 ST
EAN	4024941260534
Length	116 mm
Width	90 mm
Height	148 mm
Weight	0.338 kg
Volume	1,545.12 ccm
Packaging	Carton
Content amount	10 ST
EAN	4024941823067
Length	325 mm
Width	217 mm
Height	210 mm
Weight	3.576 kg
Volume	13,588.4 ccm

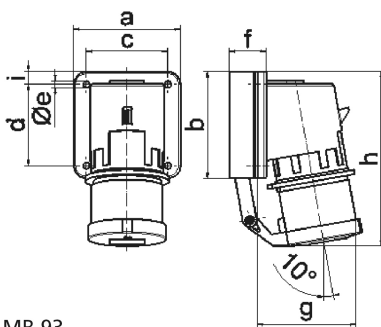

Ampere	16	32				
Polzahl	5	5				
a	84,0	90,0				
b	84,0	75,0				
c	64,0	78,0				
d	64,0	45,0				
e ø	5,5	5,5				
f	29,0	29,0				
g	105,0	115,0				
h	138,0	150,0				
i	10,0	13,0				
Leiter mm <sup>2</sup> min	1	2,5				
Leiter mm <sup>2</sup> max	2,5	6				