

THIS COPY IS PROVIDED ON A RESTRICTED BASIS AND IS NOT TO BE USED IN ANY WAY DETRIMENTAL TO THE INTERESTS OF PANDUIT CORP.

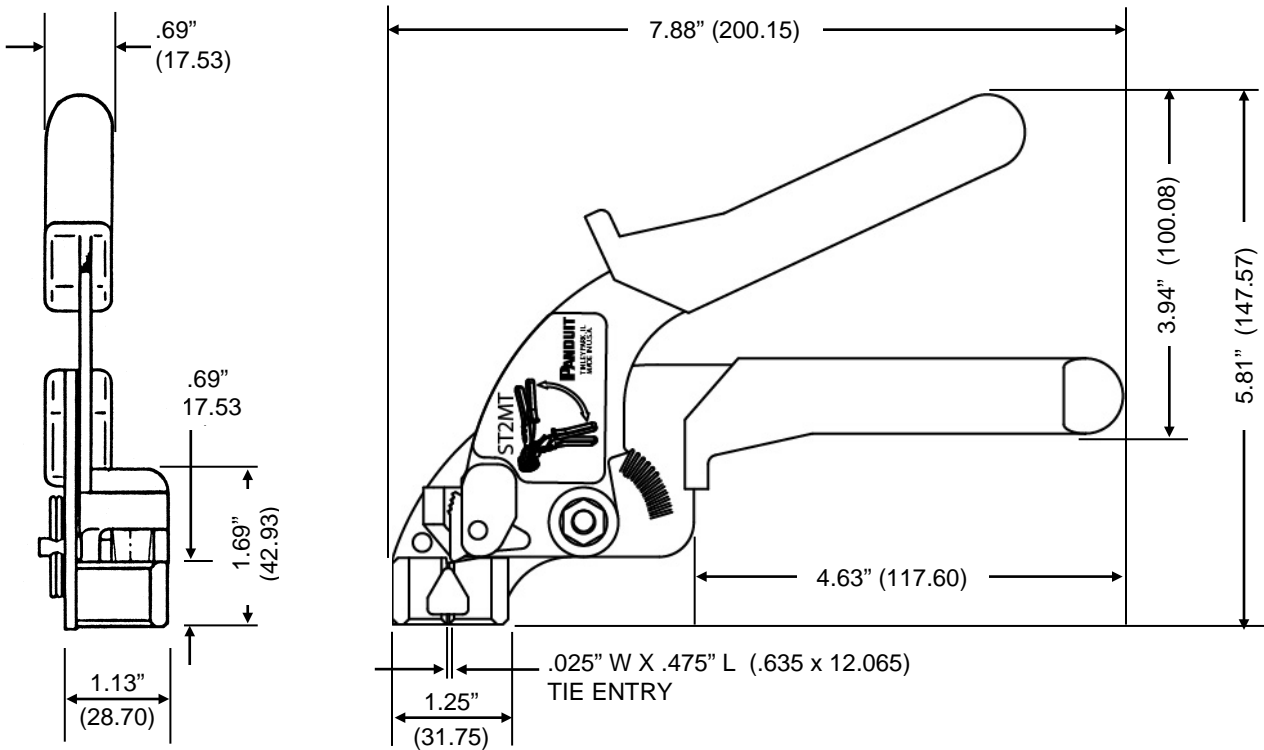

NOTES, UNLESS OTHERWISE SPECIFIED:

PANDUIT TOOL NUMBER ST2MT IS USED TO INSTALL ALL STANDARD, LIGHT-HEAVY, HEAVY AND EXTRA-HEAVY CROSS SECTION PAN-STEEL TYPE MLT TIES, TYPE MLTC COATED TIES AND TYPE MLTDH DOUBLE WRAPPED TIES.

THIS TOOL'S FEATURES INCLUDE:

- Cable tie side entry for immediate positioning of tie and tool
- One hand operation – lightweight
- Installer controlled tension
- Cut-off capability with the twist of the wrist
- Easy removal of excess tie

CABLE TIE CODE:

MLT = Metal Locking Tie
 MLTC = Nylon 11 Coated Stainless Steel Tie
 MLTDH = Double Wrapped Stainless Steel Cable Tie

TOOL WEIGHT = 16 OZ. (454 GRAMS)

DIMENSIONS SHOWN IN PARENTHESIS ARE METRIC (MM).

							ST2MT STAINLESS STEEL TIE INSTALLATION TOOL					
							CUSTOMER DRAWING					
							ITEM REVISION NAME:		PANDUIT			
							TB24535A01_04					
							UNLESS OTHERWISE SPECIFIED, DIMENSIONAL TOLERANCES ARE:			MATERIAL:		
							(.x) ± --- (.xxx) ± ---			-----		
							(.xx) ± --- ANGLES ± ---					
							THIRD ANGLE PROJECTION			DRAWING NUMBER: TB24535A01		
REV	DATE	BY	CHK	APR	DESCRIPTION	ECN	DRAWN BY: WDE	DATE: 1-17-02	CHK ABJ	SCALE NONE	SHT 1 OF 1	SIZE A
04	2-08-17	BLR	BJPU	JADE	UPD (METRIC) DIMS TO MM	12396						
03	2-07-13	BLR	BJPU	ABJ	UPD TEMPLATE & BRANDING	4609						